

CATALOG #63 2021

LIQUID HANDLING PRODUCTS

# CONNECT WITH CONFIDENCE™

CATALOG #63 EFFECTIVE OCTOBER 1, 2021

WWW.FROLIK.PL

# 2022



# INDEX

NEW PRODUCTS	4
VALVES	5-16
ELECTRIC VALVES	17-22
MANIFOLD FLANGE CONNECTIONS	23-50
DRY-MATES®	51-60
IBC/TANK ACCESSORIES	61-69
CAM LEVER COUPLINGS	70-75
PIPE FITTINGS	76-81
LINE STRAINERS	82-93
CENTRIFUGAL PUMPS	94-153
REFERENCE	154-167





[WWW.ROLTRONIK.PL](http://WWW.ROLTRONIK.PL)

## 2" POLY WET SEAL PUMP

### FEATURES

- Run dry capability
- Double seal contained in ethylene glycol reservoir. Carbon ceramic seal faces with stainless steel cup and spring with EPDM rubber.
- Pump end separated from engine
- V-shaped for quicker priming
- Engine warranty service available at authorized Briggs & Stratton® and Honda® dealers



WARNING! DO NOT USE WITH FLAMMABLE LIQUIDS



### 2" POLY WET SEAL PUMP ONLY

PART NO	DESCRIPTION	HP	QTY
205POW	2" POLY WET SEAL PUMP ONLY, 5 VANE IMPELLER WITH EPDM SEALS	N/A	1

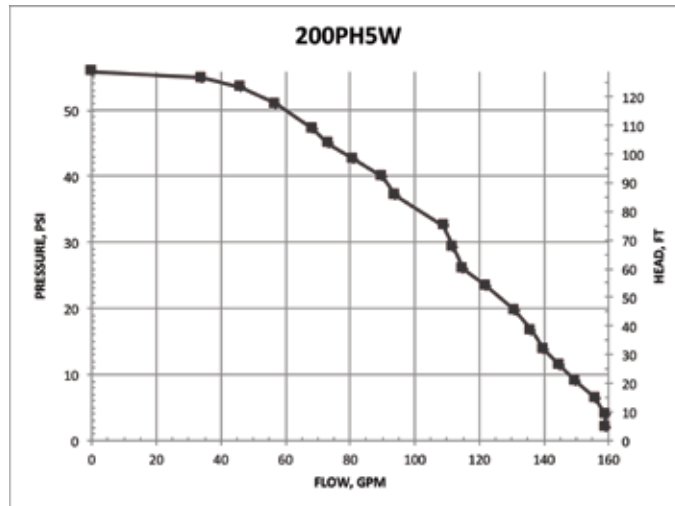

## EASY-FILL™ VALVES

### FEATURES

- Eliminates multiple fittings for fill applications
- Available in 2" and 3" sizes
- Full flow (full port) design
- Stubby valve configuration reduces profile
- Extended coupler prevents handle interference
- Carry handle available for other Banjo valves on following page



### EASY-FILL™ VALVES

PART NO	DESCRIPTION	MAX PSI	LOT QTY
VSBHB204FP	2" FULL PORT EASY-FILL™ VALVE	150	2/BOX
VSBHB205FP	2" FULL PORT EASY-FILL™ VALVE W/CARRY HANDLE	150	4/BOX
VSBHB304FP	3" FULL PORT EASY-FILL™ VALVE	150	2/BOX
VSBHB305FP	3" FULL PORT EASY-FILL™ VALVE W/CARRY HANDLE	150	4/BOX
H25053	2" & 3" CARRY HANDLE	N/A	1

# VALVES

## 1/4" -1" POLY MICRO VALVES

### FEATURES

- 90° rotating handle
- 90° locking, rotating handle (with asterisk \*)
- Precision molded polypropylene is reinforced with fiberglass for additional strength.
- Standard FKM seats and O-Rings

**JG John Guest®** Fitting

The brand "John Guest" is a registered trademark of John Guest International Limited.



### MICRO VALVES

PART NO	DESCRIPTION	MAX PSI	THREAD SIZE	OPENING THRU BALL	LOT QTY
LV025V	1/4" FEMALE NPT MICRO VALVE	300	1/4"	3/8"	10
LV038V	3/8" FEMALE NPT MICRO VALVE	300	3/8"	3/8"	10
LV050V	1/2" FEMALE NPT MICRO VALVE	300	1/2"	15/32"	10
LV050SLV	1/2" SIDE LOAD MICRO VALVE	300	1/2"	1/2"	10
LV050SLLV*	1/2" SIDE LOAD LOCKING MICRO VALVE	300	1/2"	15/32"	10

### MICRO VALVES

PART NO	DESCRIPTION	MAX PSI	THREAD SIZE	OPENING THRU	LOT QTY
LVHB038V	3/8" HOSE BARB MICRO VALVE	300	3/8"	3/8"	10
LVHB050V	1/2" HOSE BARB MICRO VALVE	300	1/2"	3/8"	10
LVHB075V	3/4" HOSE BARB MICRO VALVE	300	3/4"	15/32"	10

### MICRO VALVES

PART NO	DESCRIPTION	MAX PSI	THREAD SIZE	OPENING THRU BALL	LOT QTY
LV025MTV	1/4" FEMALE X MALE NPT MICRO VALVE	300	1/4"	3/8"	10
LV038MTV	3/8" FEMALE X MALE NPT MICRO VALVE	300	3/8"	3/8"	10
LV038050MTV	3/8" FEMALE X 1/2" MALE NPT MICRO VALVE	300	3/8" x 1/2"	3/8"	10
LV038050MTLV*	3/8" FEMALE X 1/2" MALE NPT LOCKING MICRO VALVE	300	3/8" x 1/2"	3/8"	10
LV050MTV	1/2" FEMALE X MALE NPT MICRO VALVE	300	1/2"	15/32"	10
LV050100MTV	1/2" FEMALE X 1" MALE NPT MICRO VALVE	300	1/2"	15/32"	10
LV050100MTLV*	1/2" FEMALE X 1" MALE NPT LOCKING MICRO VALVE	300	1/2" x 1"	15/32"	10

### MICRO VALVES

PART NO	DESCRIPTION	MAX PSI	THREAD SIZE	OPENING THRU BALL	LOT QTY
LVHB038050MTV	3/8" HOSE BARB X 1/2" MALE NPT MICRO VALVE	300	1/2"	3/8"	10
LVHB075MTV	3/4" HOSE BARB X 3/4" MALE NPT MICRO VALVE	300	3/4"	1/2"	10
LVHB075100MTV	3/4" HOSE BARB X 1" MALE NPT MICRO VALVE	300	1"	15/32"	10
LVHB075100MTLV	3/4" HOSE BARB X 1" MALE NPT LOCKING MICRO VALVE	300	1"	15/32"	10

### MICRO VALVES

PART NO	DESCRIPTION	MAX PSI	THREAD SIZE	OPENING THRU BALL	LOT QTY
LVPL025V	1/4" FEMALE PUSH LOCK MICRO VALVE	300	1/4"	3/8"	10
LVPL038V	3/8" FEMALE PUSH LOCK MICRO VALVE	150	3/8"	3/8"	10

## 1/2" - 2" 4 BOLTED VALVES



V100FP

V125

V200

### 4 BOLTED VALVES

PART NO	DESCRIPTION	MAX PSI	PIPE SIZE	OPENING THRU	LOT QTY	REPLACEMENT HANDLE	REPAIR KIT
V050	1/2" FULL PORT VALVE	300	1/2"	3/4"	6	V10153A	N/A
V075	3/4" FULL PORT VALVE	300	3/4"	3/4"	12	V10153A	N/A
V100	1" STANDARD PORT VALVE	225	1"	3/4"	12	V10153A	N/A
V100FP	1" FULL PORT VALVE	300	1"	1"	12	V10153A	V10200
V125	1 1/4" STANDARD PORT VALVE	300	1 1/4"	1"	6	V10153A	V10200
V125FP	1 1/4" FULL PORT VALVE	225	1 1/4"	1 1/2"	6	V20153	N/A
V150	1 1/2" FULL PORT VALVE	225	1 1/2"	1 1/2"	6	V20153	N/A
V200	2" STANDARD PORT VALVE	225	2"	1 1/2"	12	V20153	N/A

### FEATURES

- FKM seals.
- Precision molded polypropylene is reinforced with fiberglass for additional strength.
- Self-aligning ball moves freely against the PTFE seats for smooth operation. The valve opens and closes with very little pressure on the handle.
- Ball is diamond turned, after molding, to make it spherically perfect, which provides precise contact between ball and seats.
- PTFE self-lubricating stem bushings and seats cannot stick or bind.
- Stainless steel bolts.

### REPAIR KIT INCLUDES:

- Ball
- Body gasket
- Thrust washer
- Ball seats
- Upper stem bushing
- Stem o-ring



V25270

V25271

## VALVE ACCESSORIES

### FEATURES

- 304 stainless steel construction
- Installs under valve handle
- Comes complete with handle and locking device
- Padlock not included

### VALVE ACCESSORIES

PART NO	DESCRIPTION	FITS VALVES	LOT QTY
VL20153	LOCKING DEVICE	V125, V150, V200	1
V10270	STRAIGHT MOUNTING BRACKET	V100FP, V125	1
V10271	90° MOUNTING BRACKET	V100FP, V125	1
V25270	STRAIGHT MOUNTING BRACKET	V125FP, V150, V200	1
V25271	90° MOUNTING BRACKET	V125FP, V150, V200	1
V10153138	1" X 1 3/8" HANDLE OFFSET	V100FP, V125	1
V20153138	2" FP X 1 3/8" HANDLE OFFSET	V125FP, V150, V200	10
V25153138	2" FP X 1 3/8" HANDLE OFFSET	V200FP	1

# VALVES

## 2"-4" 6 BOLTED VALVES

### FEATURES

- FKM seals.
- Precision molded polypropylene is reinforced with fiberglass for additional strength.
- Self-aligning ball moves freely against the PTFE seats for smooth operation. The valve opens and closes with very little pressure on the handle.
- Ball is diamond turned, after molding, to make it spherically perfect, which provides precise contact between ball and seats.
- PTFE self-lubricating stem bushings and seats cannot stick or bind.
- Stainless steel bolts.

### REPAIR KIT INCLUDES:

- Ball
- Body gasket
- Thrust washer
- Ball seats
- Upper stem bushing
- Stem o-ring



### 6 BOLTED VALVES

PART NO	DESCRIPTION	MAX PSI	PIPE SIZE	OPENING THRU BALL	LOT QTY	REPLACEMENT HANDLE	REPAIR KIT
V200FP	2" FULL PORT VALVE	225	2"	2"	8/BOX	V25153	V25200
VFMT200FP	2" FULL PORT VALVE W/ F ADAPTER	225	2"	2"	6/BOX	V25153	V25200
V300	3" STANDARD PORT VALVE	225	3"	2½"	8/BOX	V25153	V30200
V300FP	3" FULL PORT VALVE	200	3"	3"	6/BOX	V25153	V35200
V400	4" STANDARD PORT VALVE	100	4"	3½"	4/BOX	V25153	N/A

## VALVE ACCESSORIES

### FEATURES

- Stainless steel hardware
- Locks in open and closed positions
- Locking handle replaces standard handle (sold separately)
- Padlock not included



### VALVE ACCESSORIES

PART NO	DESCRIPTION	FITS VALVES	QTY
VL25153	LOCKING HANDLE	V200FP, V300, V300FP, V400, VFMT200FP	1
V25270	STRAIGHT MOUNTING BRACKET	V200FP, V300, V300FP, V400, VFMT200FP	1
V25271	90° MOUNTING BRACKET	V200FP, V300, V300FP, V400, VFMT200FP	1



## 2" FULL PORT 4 BOLTED BALL VALVES



VFMT204FP

V204FP

### 4 BOLTED FULL PORT VALVES

PART NO	DESCRIPTION	MAX PSI	PIPE SIZE	OPENING THRU BALL	LOT QTY	REPLACEMENT HANDLE	REPAIR KIT
VFMT204FP	2" FULL PORT VALVE MALE NPT X MALE ADAPTER	150	2"	2"	6/BOX	V25153	V25200
V204FP	2" FULL PORT VALVE	150	2"	2"	8/BOX	V25153	V25200

### FEATURES

- FKM seals
- Stainless steel bolts
- PTFE self-lubricating stem bushings and seats cannot stick or bind
- Precision molded in fiberglass reinforced polypropylene
- Self-aligning ball moves freely against the PTFE seats for smoother operation
- Valve opens and closes with very little pressure on the handle
- Ball is diamond turned after molding to make it spherically perfect, which provides precise contact between ball and seats

### REPAIR KIT INCLUDES:

- Ball
- Body gasket
- Thrust washer
- Ball seats
- Upper stem bushing
- Stem o-ring

## 2" FULL PORT ANSI FLANGE BOLTED BALL VALVES



VSF200FPAF

### FULL PORT ANSI FLANGE BOLTED VALVES

PART NO	DESCRIPTION	MAX PSI	PIPE SIZE	OPENING THRU BALL	LOT QTY	REPLACEMENT HANDLE	REPAIR KIT
VSF200FPAF	2" FULL PORT VALVE MALE ADAPTER X 2" ANSI FLANGE	200	2"	2"	6/BOX	V25153SH	VS25200

### FEATURES

- 100% PTFE seats
- FKM seals
- Glass-filled polypropylene
- Unique compact design
- Lightweight
- Gaskets featured on page 73

### REPAIR KIT INCLUDES:

- Ball
- Body gasket
- Thrust washer
- Ball seats
- Upper stem bushing
- Stem o-ring

# VALVES

## 2" STANDARD PORT STUBBY BALL VALVES

### FEATURES

- Stainless steel bolts
- Glass reinforced polypropylene
- Multiple design options
- Unique patented compact design
- Lightweight
- All PTFE seals



VSF200



VSMT200



VSFMT200



VSFHB200

### 2" STANDARD PORT STUBBY VALVES

PART NO	DESCRIPTION	MAX PSI	PIPE SIZE	OPENING THRU BALL	LOT QTY	REPLACEMENT HANDLE
VSF200	2" MALE ADAPTER X 2" FEMALE NPT	100	2"	1½"	6	VS20152SH
VSMT200	2" MALE NPT X 2" FEMALE NPT	100	2"	1½"	6	VS20152SH
VSFMT200	2" MALE ADAPTER X 2" MALE NPT	225	2"	1½"	12	VS20152SH
VSFHB200	2" MALE ADAPTER X 2" HOSE BARB	100	2"	1½"	6	VS20152SH

## 2" FULL PORT STUBBY BALL VALVES



VSMT204FP



VSF204FP



VS204FP



VSFMT204FP



VSFMT204HSFP

### FEATURES

- Stainless steel bolts
- 100% PTFE ball seats
- Glass reinforced polypropylene
- Unique patented compact design
- Lightweight
- FKM body seals

### REPAIR KIT INCLUDES:

- Ball
- Body gasket
- Thrust washer
- Ball seats
- Upper stem bushing
- Stem o-ring

## 2" FULL PORT STUBBY VALVES

PART NO	DESCRIPTION	MAX PSI	PIPE SIZE	OPENING THRU BALL	LOT QTY	REPLACEMENT HANDLE	REPAIR KIT
VSMT204FP	2" MALE NPT X 2" FEMALE NPT	200	2"	2"	6	VS25153	VS25200
VSF204FP	2" MALE ADAPTER X 2" FEMALE NPT	100	2"	2"	6	VS25153	VS25200
VS204FP	2" FEMALE NPT X 2" FEMALE NPT	225	2"	2"	6	VS25153	VS25200
VSFMT204FP	2" MALE ADAPTER X 2" MALE NPT	150	2"	2"	6	VS25153	VS25200
VSFMT204HSFP	2" FP MALE ADAPTER X 2" MALE NPT W/ SS BALL, STEM & HANDLE	150	2"	2"	6	N/A	VSSH25200

# VALVES

## 3" STANDARD PORT STUBBY BALL VALVES

### FEATURES

- Stainless steel bolts
- Glass reinforced polypropylene
- FKM body seals
- Unique patented compact design
- Lightweight
- All PTFE seats



### 3" STANDARD PORT STUBBY VALVES

PART NO	DESCRIPTION	MAX PSI	PIPE SIZE	OPENING THRU BALL	LOT QTY	REPLACEMENT HANDLE STRAIGHT	REPLACEMENT HANDLE SHORT
VSF300	3" FEMALE NPT X 3" MALE ADAPTER	100	3"	2½"	6/BOX	V25153	V25153SH
VSMT300	3" FEMALE NPT X 3" MALE NPT	100	3"	2½"	6/BOX	V25153	V25153SH
VSFMT300	3" MALE NPT X 3" MALE ADAPTER	225	3"	2½"	6/BOX	V25153	V25153SH

**Note:** If repair kits not listed, components available.

## 3" FULL PORT STUBBY BALL VALVES

### FEATURES

- Stainless steel bolts
- Glass reinforced polypropylene
- FKM body seals
- Unique patented compact design
- Lightweight
- All PTFE ball seats



### 3" FULL PORT STUBBY VALVES

PART NO	DESCRIPTION	MAX PSI	PIPE SIZE	OPENING THRU BALL	LOT QTY	REPLACEMENT HANDLE
VSFMT300FP	3" FULL PORT MALE ADAPTER X 3" MALE NPT	100	3"	3"	6/BOX	V25153
VSFMT300HSFP	3" FULL PORT MALE ADAPTER X 3" MALE NPT W/SS BALL, STEM & HANDLE	100	3"	3"	6/BOX	VS30153SS

## 3 WAY BOTTOM LOAD BALL VALVES



### FEATURES

- Stainless steel bolts
- Precision molded in fiberglass reinforced polypropylene for additional strength
- Self-aligning ball moves freely against the PTFE seats for smooth operation
- Ball is diamond turned after molding to make it spherically perfect, which provides precise contact between ball and seats
- PTFE self-lubricating stem bushings and seats
- FKM body seals
- Directional flow, right or left. Valve can be turned off to stop flow

### 3 WAY BOTTOM LOAD VALVES

PART NO	DESCRIPTION	MAX PSI	PIPE SIZE	OPENING THRU BALL	LOT QTY	HANDLE TYPE	REPLACEMENT HANDLE
V075BL	¾" 3-WAY BOTTOM LOAD VALVE	200	¾"	1"	6	T	N/A
V100BL	1" FP 3-WAY BOTTOM LOAD VALVE	225	1"	1"	6	T	N/A
V125BL	1¼" 3-WAY BOTTOM LOAD VALVE	300	1¼"	1½"	6	T	V20353TB
V150BL	1½" FP 3-WAY BOTTOM LOAD VALVE	225	1½"	1½"	6	T	V20353TB
V200BL	2" FP 3-WAY BOTTOM LOAD VALVE	200	2"	2"	8/BOX	STRAIGHT	V25353B

## 3 WAY SIDE LOAD BALL VALVES



### FEATURES

- Stainless steel bolts
- Precision molded in fiberglass reinforced polypropylene for additional strength
- Self-aligning ball moves freely against the PTFE seats for smooth operation
- Ball is diamond turned after molding to make it spherically perfect, which provides precise contact between ball and seats
- PTFE self-lubricating stem bushings and seats
- FKM body seals
- Directional flow, right or left. Valve cannot be turned off to stop flow

### 3 WAY SIDE LOAD VALVES

PART NO	DESCRIPTION	MAX PSI	PIPE SIZE	OPENING THRU BALL	LOT QTY	HANDLE TYPE	REPLACEMENT HANDLE	REPAIR KIT
V075SL	¾" 3-WAY SIDE LOAD VALVE	200	¾"	1"	6	STRAIGHT	V10153A	V10300SL
V100SL	1" FP 3-WAY SIDE LOAD VALVE	200	1"	1"	6	STRAIGHT	V10153A	V10300SL
V125SL	1¼" 3-WAY SIDE LOAD VALVE	300	1¼"	1½"	6	T	N/A	V15300SL
V150SL	1½" FP 3-WAY SIDE LOAD VALVE	225	1½"	1½"	6	T	N/A	V15300SL
V200SL	2" FP 3-WAY SIDE LOAD VALVE	225	2"	2"	8/BOX	STRAIGHT	V25153SH	V25200BL

# VALVES

## 1½" - 2" NOZZLE VALVES

### FEATURES

- Lightweight hose end valve for convenient transfer of liquids into drums, tanks etc
- Angled end flange with 8" long polypropylene fill spout
- All stainless steel bolts



VA150



VA200FP

### 1½"-2" NOZZLE VALVES

PART NO	DESCRIPTION	MAX PSI	PIPE SIZE	OPENING THRU BALL	FEMALE NPT	LOT QTY	REPLACEMENT HANDLE	REPAIR KIT
VA150	1½" NOZZLE VALVE WITH 90° ELBOW	225	1½" x 8"	1½"	1½"	6	V20152	N/A
VA200	2" NOZZLE VALVE WITH 90° ELBOW	200	2" x 8"	1½"	2"	6	V20152	N/A
VA200FP	2" FP NOZZLE VALVE WITH 90° ELBOW	225	2" x 8"	2"	2"	6/BOX	V25152	V25200

## 1" DISPENSING NOZZLES

### FEATURES

- Glass reinforced polypropylene
- 304 stainless steel handle, spring and pin
- FKM rubber parts only
- Resists corrosion



VN100



V10161

### 1" DISPENSING NOZZLE

PART NO	DESCRIPTION	MAX PSI	PIPE SIZE	OPENING THRU BALL	FEMALE NPT	QTY	REPAIR KIT
VN100	1" DISPENSING NOZZLE	150	1"	N/A	1"	1	VN10200
V10161	1" NOZZLE PIPE FOR USE WITH V100, V100FP, UV100FP, SUV100FP	N/A	1"	N/A	1"	1	N/A



SUV125FP



MSUV100FP

## 1/2"-2" SINGLE UNION SPINWELD VALVES

PART NO	DESCRIPTION	MAX PSI	PIPE SIZE	OPENING THRU BALL	LOT QTY
SUV050FP	1/2" FULL PORT SINGLE UNION SPINWELD VALVE	300	1/2"	1/2"	10
SUV075FP	3/4" FULL PORT SINGLE UNION SPINWELD VALVE	300	3/4"	3/4"	10
SUV100FP	1" FULL PORT SINGLE UNION SPINWELD VALVE	300	1"	1"	10
SUV125FP	1 1/4" FULL PORT SINGLE UNION SPINWELD VALVE	300	1 1/4"	1 1/4"	10
SUV150FP	1 1/2" FULL PORT SINGLE UNION SPINWELD VALVE	300	1 1/2"	1 1/2"	10
SUV200FP	2" FULL PORT SINGLE UNION SPINWELD VALVE	200	2"	2"	10
MSUV100FP	1" MANIFOLD FULL PORT SINGLE UNION SPINWELD VALVE	300		1"	10

## 1/2" - 2" SINGLE UNION SPINWELD VALVES

### FEATURES

- Precision molded in glass reinforced polypropylene for strength and chemical resistance
- PTFE seats for smooth and proper sealing characteristics
- EPDM O-rings to handle most fertilizers and many chemicals
- Double O-rings in stem area for extra sealing protection
- Interlocking body and end plate to allow easy thread connection when installing valves



## 1/2"-2" SINGLE UNION VALVES

PART NO	DESCRIPTION	MAX PSI	PIPE SIZE	OPENING THRU BALL	LOT QTY
UV050FP	1/2" FULL PORT SINGLE UNION VALVE	300	1/2"	3/4"	10
UV075FP	3/4" FULL PORT SINGLE UNION VALVE	300	3/4"	3/4"	10
UV100FP	1" FULL PORT SINGLE UNION VALVE	300	1"	1"	10
UV125FP	1 1/4" FULL PORT SINGLE UNION VALVE	225	1 1/4"	1 1/4"	10
UV150FP	1 1/2" FULL PORT SINGLE UNION VALVE	200	1 1/2"	1 1/2"	10
UV200FP	2" FULL PORT SINGLE UNION VALVE	300	2"	2"	10

## 1/2" - 2" SINGLE UNION VALVES

### FEATURES

- Precision molded in glass reinforced polypropylene for strength and chemical resistance
- PTFE seats for smooth and proper sealing characteristics
- Double O-rings in stem area for extra sealing protection
- Interlocking body and end plate to allow easy thread connection when installing valves

# VALVES

## 1/2" - 3" CHECK VALVES

### FEATURES

- One piece construction
- Glass reinforced polypropylene
- 316 stainless steel springs
- EPDM gasket

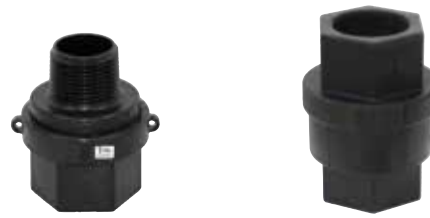

### 1/2"-3" CHECK VALVES

PART NO	DESCRIPTION	OPENING PRESSURE PSI	MAX PSI	PIPE SIZE	LOT QTY
CV050	1/2" CHECK VALVE	6-7	300	1/2"	10
CV100MT	1" MALE X FEMALE NPT CHECK VALVE	1	300	1"	10
CV100	1" CHECK VALVE	1	300	1"	10
CV221	2" FULL PORT CHECK VALVE	>0.5	300	2"	10
CV300	3" FULL PORT CHECK VALVE W/ 5 LB SPRING	1.5	300	3"	1
CV301	3" FULL PORT CHECK VALVE W/1/2 LB SPRING	>0.5	300	3"	1

## 1/4" - 3" STAINLESS STEEL FULL PORT VALVES

### FEATURES

- 316 stainless steel
- Blow out proof stem
- All valves 100% tested by air, under water at 100 PSI in open and closed positions
- Latch locking handle performs in both open and closed positions
- Mounting pad
- PTFE seals and seats



### 1/4"-3" STAINLESS STEEL FULL PORT VALVES

PART NO	DESCRIPTION	MAX PSI	PIPE SIZE	OPENING THRU BALL	QTY	REPAIR KIT
VSS025	1/4" SS FULL PORT VALVE	1000	1/4"	1/4"	1	VSS02500
VSS038	3/8" SS FULL PORT VALVE	1000	3/8"	3/8"	1	VSS02500
VSS050	1/2" SS FULL PORT VALVE	1000	1/2"	1/2"	1	VSS05200
VSS075	3/4" SS FULL PORT VALVE	1000	3/4"	3/4"	1	VSS07200
VSS100	1" SS FULL PORT VALVE	1000	1"	1"	1	VSS10200
VSS150	1 1/2" SS FULL PORT VALVE	1000	1 1/2"	1 1/2"	1	VSS15200
VSS200	2" SS FULL PORT VALVE	1000	2"	2"	1	VSS25200
VSS300	3" SS FULL PORT VALVE	1000	3"	3"	1	VSS35200

## 3/4" - 1" PINCH VALVES

### FEATURES

- Open position allows full unobstructed flow of 50-60 GPM
- Air pressure collapses the internal rubber sleeve to provide positive shut off
- Standard EPDM rubber bladder seal and FKM available
- Female NPT threads
- ATTENTION: Normally an open valve and has a maximum liquid pressure of 70 PSI. Pressure differential = pressure it takes to close valve



### 3/4"-1" PINCH VALVES

PART NO	DESCRIPTION	GASKET	MAX PSI	PIPE SIZE	PRESSURE DIFFERENTIAL	LOT QTY
PV075	3/4" X 3/4" PINCH VALVE	EPDM	300	3/4"	15 TO 20 PSI	10
PV100	1" X 1" PINCH VALVE	EPDM	300	1"	15 TO 20 PSI	1
PV100-075	1" X 3/4" PINCH VALVE	EPDM	300	1" X 3/4"	15 TO 20 PSI	10
PV100-075V	1" X 3/4" PINCH VALVE	FKM	300	1" X 3/4"	15 TO 20 PSI	1
PV10265	BLADDER	EPDM	N/A			1
PV10265V	BLADDER	FKM	N/A			1





## SMALLER

- EVX 2" full port and 3" models are over 35% smaller than the average competitive valve. The 1½", 2" full port and 3" models are also substantially lighter than the average competitive valve.

## SMARTER

- EVX offers many protocol options for your needs:
  - On/Off
  - Regulating
  - Regulating with linear feedback
  - CAN/ISO BUS
  - Proportional control
  - Pulse Width Modulation (PWM)
  - Optional Bluetooth\* for OEM applications.
- Diagnostic options for CANBUS & PWM:
  - Voltage
  - Temperature
  - Cycle Count

## TOUGHER

- Setting the new standard for electric valve toughness, EVX passes 52 separate durability torture tests including mechanical shock, vibration, extreme temperature, rain/shine, operating pressure, and rigorous longevity tests.

**SMALLER / SMARTER / TOUGHER**

\*The Bluetooth® word mark and logos are registered trademarks owned by Bluetooth SIG, Inc.

# ELECTRIC VALVES

## 3/4" - 1 1/2" EVX SERIES

### FEATURES

- 12-volt DC operated
- 24-volt available
- Open/closed indicator
- 3/4"-1 1/4" ON/OFF has 3/4 sec response
- 1 1/2" ON/OFF has 1 1/2 sec response
- Regulating has 4 sec response
- Open / Close verification available
- IP68 waterproof
- -0 to 150F (-18 to 65C) operating
- -67 to 221F (-55 to 105C) storage
- On/Off Actuator rated to 500,000 cycles
- Regulating Actuator rated to 250,000 cycles
- Valve rated to 50,000 cycles leak-free
- Bolted valves have the same exact dimensions as our legacy EV valves.
- Additional protocols available including CAN/ISO BUS, Proportional Control & PWM

### MATERIALS

- 316 stainless steel ball & stem
- Poly ball available
- Stainless steel hardware
- Fiberglass reinforced polypropylene
- PTFE seats
- FKM stem seals

### ON/OFF

- Red = +12V DC
- Black = Ground
- White = +12VDC (Open)  
0VDC (Close)

### 4 WIRE REGULATING

- Red = +12V DC (Open)
- White = Ground (Open)
- Black = +12V DC (Close)
- Green = Ground (Close)



### 3/4" - 1 1/2" EVX ON/OFF BOLTED ELECTRIC VALVES

PART NO	DESCRIPTION	MAX PSI	PIPE SIZE	OPENING THRU BALL	QTY
EVX071	3/4" FULL PORT ELECTRIC VALVE	300	3/4"	1"	1
EVX101	1" FULL PORT ELECTRIC VALVE	300	1"	1"	1
EVX121	1 1/4" STANDARD PORT ELECTRIC VALVE	300	1 1/4"	1"	1
EVX151	1 1/2" FULL PORT ELECTRIC VALVE	250	1 1/2"	1 1/2"	1

### 3/4" - 1 1/2" EVX REGULATING BOLTED ELECTRIC VALVES

PART NO	DESCRIPTION	MAX PSI	PIPE SIZE	OPENING THRU BALL	QTY
EVXR071	3/4" FULL PORT ELECTRIC VALVE	300	3/4"	1"	1
EVXR101	1" FULL PORT ELECTRIC VALVE	300	1"	1"	1
EVXR151	1 1/2" FULL PORT ELECTRIC VALVE	250	1 1/2"	1 1/2"	1

## 2" EVX SERIES



### FEATURES

- 12-volt DC operated
- 24-volt available
- Open/closed indicator
- ON/OFF has 1½ second response
- Regulating has 4 second response
- Open / Close verification available
- IP68 waterproof
- -0 to 150F (-18 to 65C) operating
- -67 to 221F (-55 to 105C) storage
- On/Off Actuator rated to 500,000 cycles
- Regulating Actuator rated to 250,000 cycles
- Valve rated to 50,000 cycles leak-free
- Bolted valves have the same exact dimensions as our legacy EV valves.
- Additional protocols available including CAN/ISO BUS, Proportional Control & PWM

### 2" EVX ON/OFF BOLTED ELECTRIC VALVES

PART NO	DESCRIPTION	MAX PSI	PIPE SIZE	OPENING THRU BALL	QTY
EVX201	2" STANDARD PORT ELECTRIC VALVE	250	2"	1½"	1
EVX221	2" FULL PORT ELECTRIC VALVE	125	2"	2"	1

### 2" EVX REGULATING BOLTED ELECTRIC VALVES

PART NO	DESCRIPTION	MAX PSI	PIPE SIZE	OPENING THRU BALL	QTY
EVXR201	2" STANDARD PORT ELECTRIC VALVE	250	2"	1½"	1
EVXR221	2" FULL PORT ELECTRIC VALVE	125	2"	2"	1

### MATERIALS

- 316 stainless steel ball & stem
- Poly ball available
- Stainless steel hardware
- Fiberglass reinforced polypropylene
- PTFE seats
- FKM stem seals

### ON/OFF

- Red = +12V DC
- Black = Ground
- White = +12VDC (Open)  
0VDC (Close)

### 4 WIRE REGULATING

- Red = +12V DC (Open)
- White = Ground (Open)
- Black = +12V DC (Close)
- Green = Ground (Close)

# ELECTRIC VALVES

## 3" EVX SERIES

### FEATURES

- 12-volt DC operated
- 24-volt available
- Open/closed indicator
- ON/OFF has 4 second response
- Regulating has 4 second response
- Open / Close verification available
- IP68 waterproof
- -0 to 150F (-18 to 65C) operating
- -67 to 221F (-55 to 105C) storage
- Actuator rated to 250,000 cycles
- Valve rated to 50,000 cycles leak-free
- Additional protocols available including CAN/ISO BUS, Proportional Control & PWM

### MATERIALS

- 316 stainless steel ball & stem
- Stainless steel hardware
- Fiberglass reinforced polypropylene
- Zinc alloy lower actuator housing
- PTFE seats
- FKM stem seals

### ON/OFF

- Red = +12V DC
- Black = Ground
- White = +12VDC (Open)  
0VDC (Close)

### 4 WIRE REGULATING

- Red = +12V DC (Open)
- White = Ground (Open)
- Black = +12V DC (Close)
- Green = Ground (Close)



### 3" EVX ON/OFF ELECTRIC VALVES

PART NO	DESCRIPTION	MAX PSI	PIPE SIZE	OPENING THRU BALL	QTY
EVX300	3" FULL PORT ELECTRIC VALVE	150	3"	3"	1

### 3" EVX REGULATING ELECTRIC VALVES

PART NO	DESCRIPTION	MAX PSI	PIPE SIZE	OPENING THRU BALL	QTY
EVXR300	3" FULL PORT ELECTRIC VALVE	125	3"	3"	1

## 3/4" - 2" EVX SERIES BOTTOM & SIDE LOAD VALVES

### FEATURES

- 12-volt DC operated
- 24-volt available
- Open/closed indicator
- 1" & 1 1/4" ON/OFF has 3/4 second response
- 1 1/2" & 2" ON/OFF has 1 1/2" second response
- Open / Close verification available
- IP68 waterproof
- -0 to 150F (-18 to 65C) operating
- -67 to 221F (-55 to 105C) storage
- On/Off Actuator rated to 500,000 cycles
- Valve rated to 50,000 cycles leak-free
- These bolted valves have the exact same dimensions as our legacy EV valves.
- Additional protocols available including CAN/ISO BUS, Proportional Control & PWM

### MATERIALS

- 316 stainless steel ball & stem
- Stainless steel hardware
- Fiberglass reinforced polypropylene
- PTFE seats
- FKM stem seals

### ON/OFF

- Red = +12V DC
- Black = Ground
- White = +12VDC (Open)  
0VDC (Close)

### 4 WIRE REGULATING

- Red = +12V DC (Open)
- White = Ground (Open)
- Black = +12V DC (Close)
- Green = Ground (Close)



### 3/4"-2" EVX BOLTED BOTTOM LOAD ELECTRIC VALVES

PART NO	DESCRIPTION	MAX PSI	PIPE SIZE	OPENING THRU BALL	QTY
EVX075BL	3/4" FULL PORT BOTTOM LOAD ELECTRIC VALVE	300	3/4"	1"	1
EVX100BL	1" FULL PORT BOTTOM LOAD ELECTRIC VALVE	300	1"	1"	1
EVX125BL	1 1/4" FULL PORT SIDE LOAD ELECTRIC VALVE	250	1 1/4"	1"	1
EVX150BL	1 1/2" FULL PORT SIDE LOAD ELECTRIC VALVE	250	1 1/2"	1 1/2"	1
EVX200BL	2" STANDARD PORT BOTTOM LOAD ELECTRIC VALVE	250	2"	1 1/2"	1
EVX220BL	2" FULL PORT BOTTOM LOAD ELECTRIC VALVE	125	2"	2"	1

### 3/4"-2" EVX BOLTED SIDE LOAD ELECTRIC VALVES

PART NO	DESCRIPTION	MAX PSI	PIPE SIZE	OPENING THRU BALL	QTY
EVX075SL	3/4" FULL PORT SIDE LOAD ELECTRIC VALVE	300	3/4"	1"	1
EVX100SL	1" FULL PORT SIDE LOAD ELECTRIC VALVE	300	1"	1"	1
EVX125SL	1 1/4" FULL PORT SIDE LOAD ELECTRIC VALVE	250	1 1/4"	1"	1
EVX150SL	1 1/2" FULL PORT SIDE LOAD ELECTRIC VALVE	250	1 1/2"	1 1/2"	1
EVX200SL	2" STANDARD PORT SIDE LOAD ELECTRIC VALVE	250	2"	1 1/2"	1
EVX220SL	2" FULL PORT SIDE LOAD ELECTRIC VALVE	125	2"	2"	1

# ELECTRIC VALVES

## 3/8" - 1/2" LEV SERIES

### FEATURES

- 12 Volt DC
- Stationary current draw: less than 0.04 amps
- Rotating current draw: less than 0.40 amps
- Stall current: 0.75 amps
- Response time: 1/3 second open to close
- TFM seats
- EPDM seals
- Fiberglass reinforced polypropylene
- Integrated mounting slot
- Standard 3 wire configuration



LEV038



LEV050

### 3/8" - 1/2" ON/OFF ELECTRIC VALVES

PART NO	DESCRIPTION	MAX PSI	PIPE SIZE	OPENING THRU BALL	QTY
LEV038	3/8" FULL PORT ELECTRIC VALVE	300	3/8"	3/8"	1
LEV050	1/2" ELECTRIC VALVE	300	1/2"	15/32"	1



LEV038PL

### 3/8" ELECTRIC VALVES W/ PUSH LOCK

PART NO	DESCRIPTION	MAX PSI	PIPE SIZE	OPENING THRU BALL	QTY
LEV038PL	3/8" FULL PORT ELECTRIC VALVE W/ PUSH LOCK	150	3/8"	3/8"	1

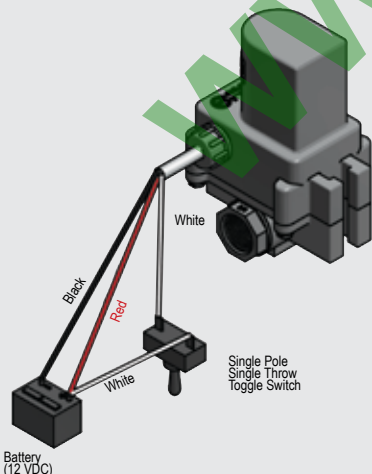

# MANIFOLD FLANGE CONNECTIONS

NO THREADS. NO SWEAT.

FLANGE CONNECTIONS FOR EVERY PRODUCT

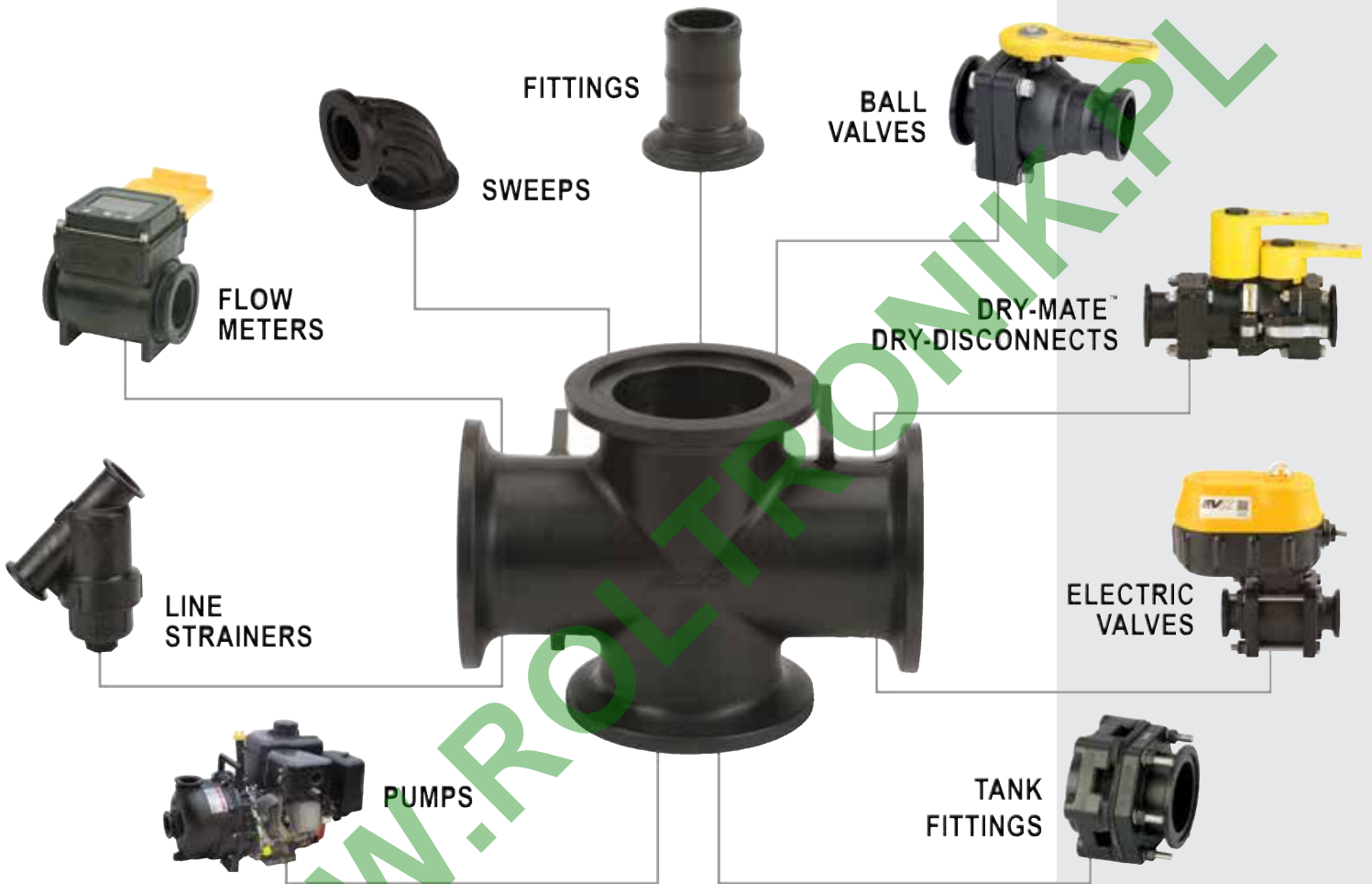

## ⚙️ SKIP THE TAPE AND SEALANT

Flange connections utilize clamp instead of threads, facilitating quick and easy assembly and disassembly while ensuring a leak-proof system. Threaded pipe needs tape or sealant, and the slightest imperfection in the pipe or seal can cause a leak. With properly installed flange connections, you won't worry about connection leaks or wait for sealant to cure.

## ⌚ SAVE TIME. SAVE MONEY.

Time spent unthreading systems and repairing leaks from faulty connections is unproductive and ultimately hits your pocketbook. Banjo's manifold flange systems get you back in the field and out of the shop in no time.

## ➡️ GET RIGHT TO THE SOURCE

With Banjo manifold flange connections, the days of spending hours unhooking entire systems of valves and fittings are over. You can directly isolate and replace the problematic part or replumb sections without disassembling the whole system.

# MANIFOLD FLANGE CONNECTIONS

## 1" MEVX SERIES

### FEATURES

- 12-volt DC operated
- 24-volt available
- Open/closed indicator
- ON/OFF has ¾ second response
- Regulating has 4 second response
- Open / Close verification available
- IP68 waterproof
- -0 to 150F (-18 to 65C) operating
- -67 to 221F (-55 to 105C) storage
- On/Off Actuator rated to 500,000 cycles
- Regulating Actuator rated to 250,000 cycles
- Valve rated to 50,000 cycles leak-free
- Bolted valves have the same exact dimensions as our legacy EV valves.
- Additional protocols available including CAN/ISO BUS, Proportional Control & PWM

### MATERIALS

- 316 stainless steel ball & stem
- Poly ball available on bolted valves
- Stainless steel hardware
- Fiberglass reinforced polypropylene
- PTFE seats
- FKM stem seals

### ON/OFF

- Red = +12V DC
- Black = Ground
- White = +12VDC (Open)  
0VDC (Close)

### 4 WIRE REGULATING

- Red = +12V DC (Open)
- White = Ground (Open)
- Black = +12V DC (Close)
- Green = Ground (Close)



### 1" MEVX ON/OFF WELDED ELECTRIC VALVES

PART NO	DESCRIPTION	MAX PSI	PIPE SIZE	OPENING THRU BALL	QTY
MEVX100	1" FULL PORT ELECTRIC VALVE	300	1"	1"	1

### 1" MEVX REGULATING WELDED ELECTRIC VALVES

PART NO	DESCRIPTION	MAX PSI	PIPE SIZE	OPENING THRU BALL	QTY
MEVXR100	1" FULL PORT ELECTRIC VALVE	300	1"	1"	1

### 1" MEVX ON/OFF BOLTED ELECTRIC VALVES

PART NO	DESCRIPTION	MAX PSI	PIPE SIZE	OPENING THRU BALL	QTY
MEVX101	1" FULL PORT ELECTRIC VALVE	300	1"	1"	1

### 1" MEVX REGULATING BOLTED ELECTRIC VALVES

PART NO	DESCRIPTION	MAX PSI	PIPE SIZE	OPENING THRU BALL	QTY
MEVXR101	1" FULL PORT ELECTRIC VALVE	300	1"	1"	1



# MANIFOLD FLANGE CONNECTIONS



## 2" MEVX SERIES

### FEATURES

- 12-volt DC operated
- 24-volt available
- Open/closed indicator
- ON/OFF has 1½ second response
- Regulating has 4 second response
- Open / Close verification available
- IP68 waterproof
- -0 to 150F (-18 to 65C) operating
- -67 to 221F (-55 to 105C) storage
- On/Off Actuator rated to 500,000 cycles
- Regulating Actuator rated to 250,000 cycles
- Valve rated to 50,000 cycles leak-free
- Bolted valves have the same exact dimensions as our legacy EV valves.
- Additional protocols available including CAN/ISO BUS, Proportional Control & PWM

### MATERIALS

- 316 stainless steel ball & stem
- Poly ball available on bolted valves
- Stainless steel hardware
- Fiberglass reinforced polypropylene
- PTFE seats
- FKM stem seals

### ON/OFF

- Red = +12V DC
- Black = Ground
- White = +12VDC (Open)  
0VDC (Close)

### 4 WIRE REGULATING

- Red = +12V DC (Open)
- White = Ground (Open)
- Black = +12V DC (Close)
- Green = Ground (Close)

### 2" MEVX ON/OFF WELDED ELECTRIC VALVES

PART NO	DESCRIPTION	MAX PSI	PIPE SIZE	OPENING THRU BALL	QTY
MEVX200	2" STANDARD PORT ELECTRIC VALVE	300	2"	1½"	1
MEVX220	2" FULL PORT ELECTRIC VALVE	250	2"	2"	1

### 2" MEVX REGULATING WELDED ELECTRIC VALVES

PART NO	DESCRIPTION	MAX PSI	PIPE SIZE	OPENING THRU BALL	QTY
MEVXR200	2" STANDARD PORT ELECTRIC VALVE	250	2"	1½"	1
MEVXR220	2" FULL PORT ELECTRIC VALVE	250	2"	2"	1

### 2" MEVX ON/OFF BOLTED ELECTRIC VALVES

PART NO	DESCRIPTION	MAX PSI	PIPE SIZE	OPENING THRU BALL	QTY
MEVX201	2" STANDARD PORT ELECTRIC VALVE	250	2"	1½"	1
MEVX221	2" FULL PORT ELECTRIC VALVE	125	2"	2"	1

# MANIFOLD FLANGE CONNECTIONS

## 3" MEVX SERIES

### FEATURES

- 12-volt DC operated
- 24-volt available
- Open/closed indicator
- ON/OFF 3" has 4 second response
- Regulating 3" has 4 second response
- Open / Close verification available
- IP68 waterproof
- -0 to 150F (-18 to 65C) operating
- -67 to 221F (-55 to 105C) storage
- Actuator rated to 250,000 cycles
- Valve rated to 50,000 cycles leak-free
- Additional protocols available including CAN/ISO BUS, Proportional Control & PWM

### MATERIALS

- 316 stainless steel ball & stem
- Stainless steel hardware
- Fiberglass reinforced polypropylene
- Zinc alloy lower actuator housing
- PTFE seats
- FKM stem seals

### ON/OFF

- Red = +12V DC
- Black = Ground
- White = +12VDC (Open)  
0VDC (Close)

### 4 WIRE REGULATING

- Red = +12V DC (Open)
- White = Ground (Open)
- Black = +12V DC (Close)
- Green = Ground (Close)



### 3" MEVX ON/OFF ELECTRIC VALVES

PART NO	DESCRIPTION	MAX PSI	PIPE SIZE	OPENING THRU BALL	QTY
MEVX300	3" FULL PORT ELECTRIC VALVE	150	3"	3"	1

### 3" MEVX REGULATING ELECTRIC VALVES

PART NO	DESCRIPTION	MAX PSI	PIPE SIZE	OPENING THRU BALL	QTY
MEVXR300	3" FULL PORT ELECTRIC VALVE	125	3"	3"	1

# MANIFOLD FLANGE CONNECTIONS

## 1"- 3" MEVX SERIES BOTTOM & SIDE LOAD VALVES



### FEATURES

- 12-volt DC operated
- 24-volt available
- Open/closed indicator
- ON/OFF 1" has ¾ second response
- ON/OFF 2" has 1½ second response
- ON/OFF 3" has 4 second response
- Open / Close verification available
- IP68 waterproof
- -0 to 150F (-18 to 65C) operating
- -67 to 221F (-55 to 105C) storage
- 1"-2" On/Off Actuator rated to 500,000 cycles
- 3" On/Off & Regulating Actuator rated to 250,000 cycles
- Valve rated to 50,000 cycles leak-free
- Additional protocols available including CAN/ISO BUS, Proportional Control & PWM

### 1"-3" MEVX BOTTOM LOAD ELECTRIC VALVES

PART NO	DESCRIPTION	MAX PSI	PIPE SIZE	OPENING THRU BALL	QTY
MEVX100BL	1" FULL PORT MANIFOLD BOTTOM LOAD ELECTRIC VALVE	300	1"	1"	1
MEVX200BL	2" STANDARD PORT MANIFOLD BOTTOM LOAD ELECTRIC VALVE	250	2"	1½"	1
MEVX220BL	2" FULL PORT MANIFOLD BOTTOM LOAD ELECTRIC VALVE	125	2"	2"	1
MEVX300BL	3" FULL PORT MANIFOLD BOTTOM LOAD ELECTRIC VALVE	200	3"	3"	1

### 1"-2" MEVX SIDE LOAD ELECTRIC VALVES

PART NO	DESCRIPTION	MAX PSI	PIPE SIZE	OPENING THRU BALL	QTY
MEVX100SL	1" FULL PORT MANIFOLD SIDE LOAD ELECTRIC VALVE	300	1"	1"	1
MEVX200SL	2" STANDARD PORT MANIFOLD SIDE LOAD ELECTRIC VALVE	250	2"	1½"	1
MEVX220SL	2" FULL PORT MANIFOLD SIDE LOAD ELECTRIC VALVE	125	2"	2"	1

### 1"-2" MEVX SIDE LOAD REGULATING ELECTRIC VALVES

PART NO	DESCRIPTION	MAX PSI	PIPE SIZE	OPENING THRU BALL	QTY
MEVXR100SL	1" FULL PORT MANIFOLD SIDE LOAD ELECTRIC VALVE	300	1"	1"	1
MEVXR200SL	2" STANDARD PORT MANIFOLD SIDE LOAD ELECTRIC VALVE	250	2"	1½"	1
MEVXR220SL	2" FULL PORT MANIFOLD SIDE LOAD ELECTRIC VALVE	125	2"	2"	1

### MATERIALS

- 316 stainless steel ball & stem
- Stainless steel hardware
- Fiberglass reinforced polypropylene
- Zinc alloy lower actuator housing (3" only)
- PTFE seats
- FKM stem seals

### ON/OFF

- Red = +12V DC
- Black = Ground
- White = +12VDC (Open)  
0VDC (Close)

### 4 WIRE REGULATING

- Red = +12V DC (Open)
- White = Ground (Open)
- Black = +12V DC (Close)
- Green = Ground (Close)

# MANIFOLD FLANGE CONNECTIONS

## MEVX BANKED VALVES



### FEATURES

- Valve sizes 1"-2" SP
- Number of valves from two to five bank
- Welded or bolted valves available
- Bolted valves have the same exact dimensions as our legacy EV valves.
- Additional protocols available including CAN/ISO BUS, Proportional Control & PWM

### MEVX ON/OFF WELDED BANKED ELECTRIC VALVES

PART NO	DESCRIPTION	MAX PSI	PIPE SIZE	OPENING THRU BALL	QTY
MEVX102	1" FULL PORT 2 BANK ELECTRIC VALVE	300	1"	1"	1
MEVX103	1" FULL PORT 3 BANK ELECTRIC VALVE	300	1"	1"	1
MEVX104	1" FULL PORT 4 BANK ELECTRIC VALVE	300	1"	1"	1
MEVX105	1" FULL PORT 5 BANK ELECTRIC VALVE	300	1"	1"	1

### MEVX ON/OFF BOLTED BANKED ELECTRIC VALVES

PART NO	DESCRIPTION	MAX PSI	PIPE SIZE	OPENING THRU BALL	QTY
MEVX1012	1" FULL PORT 2 BANK ELECTRIC VALVE	300	1"	1"	1
MEVX1013	1" FULL PORT 3 BANK ELECTRIC VALVE	300	1"	1"	1
MEVX1014	1" FULL PORT 4 BANK ELECTRIC VALVE	300	1"	1"	1
MEVX1015	1" FULL PORT 5 BANK ELECTRIC VALVE	300	1"	1"	1

## 1" LEV ELECTRIC MANIFOLD VALVE

### FEATURES

- TFM seats & EPDM seals
- 12-volt DC operated
- Internally fused/automatic reset
- Stationary current draw: less than 0.04 amps
- Rotating current draw: less than 0.40 amps
- Stall current: 0.75 amps
- 1/3 second response time
- Integrated mounting slot
- 3 wire configuration
- Higher torque motor to power through thick liquids and demanding applications. (MLEV100A)
- Reinforced nylon stem more than triples the strength of the standard 1" LEV. (MLEV100A)



MLEV100

MLEV100A

MLEV100C

### 1" ON/OFF ELECTRIC VALVES

PART NO	DESCRIPTION	MAX PSI	PIPE SIZE	OPENING THRU BALL	QTY
MLEV100	1" MANIFOLD ELECTRIC VALVE	300	1"	1/2"	1
MLEV100A	1" MANIFOLD ELECTRIC VALVE WITH HIGHER TORQUE MOTOR, SS BALL	300	1"	1/2"	1
MLEV100C	1" MANIFOLD ELECTRIC VALVE WITH HIGHER TORQUE MOTOR, SS BALL, 3 WIRE	300	1"	1/2"	1

### ON/OFF

- Red = +12V DC
- Black = Ground
- White = +12VDC (Open)  
0VDC (Close)

# MANIFOLD FLANGE CONNECTIONS



MV200CF

MV300CF

## MANIFOLD 4 & 6 BOLTED VALVES

PART NO	DESCRIPTION	MAX PSI	PIPE SIZE	OPENING THRU BALL	LOT QTY	REPLACEMENT HANDLE	REPAIR KIT
MV100CF	1" FULL PORT MANIFOLD VALVE	300	1"	1"	12	V10153A	V10200
MV200CF	2" STANDARD PORT MANIFOLD VALVE	225	2"	1½"	12/BOX	V20153	N/A
MV220CF	2" FULL PORT MANIFOLD VALVE	300	2"	2"	8/BOX	V25153	V25200
MV300	3" STANDARD PORT MANIFOLD VALVE	150	3"	2½"	6/BOX	V25153	V30200
MV300CF	3" FULL PORT MANIFOLD VALVE	200	3"	3"	6/BOX	V25153	V35200

## 1" - 3" 4 & 6 BOLTED VALVES

### FEATURES

- FKM seals.
- Precision molded polypropylene is reinforced with fiberglass for additional strength
- Self-aligning ball moves freely against the PTFE seats for smooth operation. The valve opens and closes with very little pressure on the handle
- Ball is diamond turned, after molding, to make it spherically perfect, which provides precise contact between ball and seats.
- PTFE self-lubricating stem bushings and seats cannot stick or bind
- Stainless steel bolts

### REPAIR KIT INCLUDES:

- Ball
- Body gasket
- Thrust washer
- Ball seats
- Upper stem bushing
- Stem o-ring



## MANIFOLD BOLTED 5 WAY VALVE

PART NO	DESCRIPTION	MAX PSI	PIPE SIZE	OPENING THRU BALL	QTY
MV225CF	2" FULL PORT MANIFOLD 5 WAY VALVE	100	2"	2"	1

## 2" BOLTED 5 WAY VALVE

### FEATURES

- FKM seals
- Precision molded polypropylene is reinforced with fiberglass for additional strength
- Self-aligning ball moves freely against the PTFE seats for smooth operation. The valve opens and closes with very little pressure on the handle
- Ball is diamond turned, after molding, to make it spherically perfect, which provides precise contact between ball and seats.
- PTFE self-lubricating stem bushings and seats cannot stick or bind
- Stainless steel bolts

# MANIFOLD FLANGE CONNECTIONS

## 2" STUBBY VALVES

### FEATURES

- Precision molded polypropylene is reinforced with fiberglass for additional strength.
- Self-aligning ball moves freely against the PTFE seats for smooth operation. The valve opens and closes with very little pressure on the handle.
- Ball is diamond turned, after molding, to make it spherically perfect, which provides precise contact between ball and seats.
- PTFE self-lubricating stem bushings and seats cannot stick or bind.
- Stainless steel bolts.
- Standard size has TFE seals and Full Port size has FKM seals



VSMT200CF



VSF200CF



MVS220FP



MVSF220FP



MVS220CF



MVSMT220FP

### 2" MANIFOLD STUBBY VALVES

PART NO	DESCRIPTION	MAX PSI	PIPE SIZE	OPENING THRU BALL	LOT QTY	REPLACEMENT HANDLE	REPAIR KIT
VSMT200CF	2" STANDARD PORT MANIFOLD VALVE FLANGE X MALE NPT W/TFE SEALS	150	2"	1½"	6	VS20152SH	N/A
VSF200CF	2" STANDARD PORT MANIFOLD VALVE FLANGE X MALE ADAPTER W/TFE SEALS	100	2"	1½"	6	VS20152SH	N/A
MVS220FP	2" FULL PORT MANIFOLD VALVE FLANGE X FEMALE NPT W/FKM SEALS	300	2"	2"	6	VS25153	VS25200
MVSF220FP	2" FULL PORT MANIFOLD VALVE FLANGE X MALE ADAPTER W/FKM SEALS	150	2"	2"	9	VS25153	VS25200
MVS220CF	2" FULL PORT MANIFOLD VALVE FLANGE X FLANGE W/FKM SEALS	150	2"	2"	9	VS25153	VS25200
MVSMT220FP	2" FULL PORT MANIFOLD VALVE FLANGE X MALE NPT W/FKM SEALS	225	2"	2"	9	VS25153	VS25200

**Note:** N/A repair kits, components available.

# MANIFOLD FLANGE CONNECTIONS

## 2" FP STUBBY VALVES WITH STAINLESS STEEL



MVS220HSFP

### 2" FULL PORT MANIFOLD STUBBY VALVES WITH SS

PART NO	DESCRIPTION	MAX PSI	PIPE SIZE	OPENING THRU BALL	QTY
MVS220HSFP	2" FULL PORT MANIFOLD STUBBY VALVE FLANGE X FLANGE WITH SS BALL, STEM & HANDLE	200	2"	2"	1

### FEATURES

- Precision molded polypropylene is reinforced with fiberglass for additional strength.
- Self-aligning ball moves freely against the PTFE seats for smooth operation. The valve opens and closes with very little pressure on the handle.
- Stainless steel bolts
- Compact design
- FKM seals

## 2" FP STUBBY STAINLESS STEEL VALVE



VSFMT220SS

### 2" FULL PORT MANIFOLD STUBBY STAINLESS STEEL VALVE

PART NO	DESCRIPTION	MAX PSI	PIPE SIZE	OPENING THRU BALL	QTY	REPLACEMENT HANDLE	REPAIR KIT
VSFMT220SS	2" FULL PORT MANIFOLD STUBBY SS VALVE MALE THREAD X MALE ADAPTER	150	2"	2"	1	VSS20153	VSS25200

### FEATURES

- PTFE seals, no elastomers
- Self-aligning ball moves freely against the PTFE seats for smooth operation. The valve opens and closes with very little pressure on the handle
- PTFE self-lubricating stem bushings and seats cannot stick or bind

# MANIFOLD FLANGE CONNECTIONS

## 3" STUBBY VALVES

### FEATURES

- FKM seals.
- Precision molded polypropylene is reinforced with fiberglass for additional strength.
- Self-aligning ball moves freely against the PTFE seats for smooth operation. The valve opens and closes with very little pressure on the handle.
- Ball is diamond turned, after molding, to make it spherically perfect, which provides precise contact between ball and seats.
- PTFE self-lubricating stem bushings and seats cannot stick or bind.
- Stainless steel bolts.



### 3" MANIFOLD STUBBY VALVES

PART NO	DESCRIPTION	MAX PSI	PIPE SIZE	OPENING THRU BALL	LOT QTY	REPLACEMENT HANDLE	REPAIR KIT
MVSF300	3" STANDARD PORT MANIFOLD VALVE FLANGE X MALE ADAPTER	100	3"	2½"	6/BOX	V25153	N/A
MVSF300FP	3" FULL PORT MANIFOLD VALVE FLANGE X MALE ADAPTER	100	3"	3"	6/BOX	V25153	VS35200
MVSMT300	3" STANDARD PORT MANIFOLD VALVE FLANGE X MALE NPT	225	3"	2½"	4	V25153	N/A
MVS300CF	3" STANDARD PORT MANIFOLD VALVE FLANGE X FLANGE	200	3"	2½"	6/BOX	V25153	N/A
MVS300CFFP	3" FULL PORT MANIFOLD VALVE FLANGE X FLANGE	150	3"	3"	6/BOX	V25153	VS35200

**Note:** N/A repair kits, components available.



# MANIFOLD FLANGE CONNECTIONS

## 3" FP STUBBY VALVES WITH STAINLESS STEEL

### FEATURES

- Precision molded polypropylene is reinforced with fiberglass for additional strength.
- Self-aligning ball moves freely against the PTFE seats for smooth operation. The valve opens and closes with very little pressure on the handle.
- Ball is diamond turned, after molding, to make it spherically perfect, which provides precise contact between ball and seats.
- Stainless steel bolts
- Compact design
- FKM seals



MVS300HSFP



MVSMT300HSFP

### 3" FULL PORT MANIFOLD STUBBY VALVES WITH SS

PART NO	DESCRIPTION	MAX PSI	PIPE SIZE	OPENING THRU BALL	QTY	REPLACEMENT HANDLE
MVS300HSFP	3" FULL PORT MANIFOLD STUBBY VALVE FLANGE X FLANGE WITH SS BALL, STEM & HANDLE	100	3"	3"	1	VS30153SS
MVSMT300HSFP	3" FULL PORT MANIFOLD STUBBY VALVE MALE NPT X FLANGE WITH SS BALL, STEM & HANDLE	200	3"	3"	1	VS30153SS

# MANIFOLD FLANGE CONNECTIONS

## 3 WAY BOTTOM LOAD BALL VALVES

### FEATURES

- Stainless steel bolts
- Precision molded in fiberglass reinforced polypropylene for additional strength
- Self-aligning ball moves freely against the PTFE seats for smooth operation
- Ball is diamond turned after molding to make it spherically perfect, which provides precise contact between ball and seats
- PTFE self-lubricating stem bushings and seats
- FKM body seals
- Directional flow, right or left. Valve can be turned off to stop flow

### REPAIR KIT INCLUDES:

- Ball
- Body gasket
- Thrust washer
- Ball seats
- Upper stem bushing
- Stem o-ring



### 3 WAY BOTTOM LOAD MANIFOLD VALVES

PART NO	DESCRIPTION	MAX PSI	PIPE SIZE	OPENING THRU BALL	LOT QTY	HANDLE TYPE	REPLACEMENT HANDLE	REPAIR KIT
MV100BL	1" FP 3-WAY BOTTOM LOAD MANIFOLD VALVE	300	1"	1"	6	T	N/A	N/A
MV200BL	2" SP 3-WAY BOTTOM LOAD MANIFOLD VALVE	225	2"	1½"	6	T	V20353TB	V15300SL
MV220BL	2" FP 3-WAY BOTTOM LOAD MANIFOLD VALVE	150	2"	2"	8/BOX	STRAIGHT	V25353B	N/A
MV300BL	3" FP 3-WAY BOTTOM LOAD MANIFOLD VALVE	150	3"	3"	4/BOX	STRAIGHT	V25353B	V35200BL

## 3 WAY SIDE LOAD BALL VALVES

### FEATURES

- Stainless steel bolts
- Precision molded in fiberglass reinforced polypropylene for additional strength
- Self-aligning ball moves freely against the PTFE seats for smooth operation
- Ball is diamond turned after molding to make it spherically perfect, which provides precise contact between ball and seats
- PTFE self-lubricating stem bushings and seats
- FKM body seals
- Directional flow, right or left. Valve cannot be turned off to stop flow



### 3 WAY SIDE LOAD MANIFOLD VALVES

PART NO	DESCRIPTION	MAX PSI	PIPE SIZE	OPENING THRU BALL	LOT QTY	HANDLE TYPE	REPLACEMENT HANDLE	REPAIR KIT
MV100SL	1" FP 3-WAY SIDE LOAD MANIFOLD VALVE	300	1"	1"	6	T	N/A	MV10300SL
MV200SL	2" SP 3-WAY SIDE LOAD MANIFOLD VALVE	225	2"	1½"	5	STRAIGHT	V20153SH	V15300SL
MV220SL	2" FP 3-WAY SIDE LOAD FULL PORT MANIFOLD VALVE	100	2"	2"	8/BOX	STRAIGHT	V25153SH	V25200BL

# MANIFOLD FLANGE CONNECTIONS

## PRESSURE SPIKE VALVES



### FEATURES

- FKM seals.
- Precision molded polypropylene is reinforced with fiberglass for additional strength.
- 360° orientation
- Preset pressure spring

### MANIFOLD PRESSURE SPIKE VALVES

PART NO	DESCRIPTION	CRACKING PRESSURE	MAX PSI	QTY
MPRV100-050	1" X 1" MANIFOLD PRESSURE SPIKE VALVE	50	300	1
MPRV100-075	1" X 1" MANIFOLD PRESSURE SPIKE VALVE	75	300	1
MPRV100-100	1" X 1" MANIFOLD PRESSURE SPIKE VALVE	100	300	1
MPRV100-125	1" X 1" MANIFOLD PRESSURE SPIKE VALVE	125	300	1

## DRY-MATE™ DRY-DISCONNECTS



### FEATURES

- Easy to use
- Minimal fluid spillage
- Reduces risk of exposure
- Wide range of chemical resistance
- When properly installed and operated, the assembly will not accidentally separate while fluid is flowing; preventing costly mishaps.
- Spillage data: 2"=4ml, 3"=15ml

### MANIFOLD DRY DISCONNECTS

PART NO	DESCRIPTION	MAX PSI	PIPE SIZE	OPENING THRU BALL	QTY	REPLACEMENT HANDLE	REPAIR KIT
DM200ACF	2" MALE MANIFOLD DRY-MATE WITH FKM SEALS	100	2"	1½"	1	DM20153M	DM20200A
DM200DCF	2" FEMALE MANIFOLD DRY-MATE WITH FKM SEALS	100	2"	1½"	1	DM20153F	DM20200D
DM300ACF	3" MALE MANIFOLD DRY-MATE WITH FKM SEALS	150	3"	3"	1	DM35153M	DM35200
DM300DCF	3" FEMALE MANIFOLD DRY-MATE WITH FKM SEALS	150	3"	3"	1	DM35153F	DM35200

**Note:** Male and female sold separately

### REPAIR KIT INCLUDES:

- Face seal
- Ball
- Seats
- Body gasket
- Thrust bearings
- Stem bushings

# MANIFOLD FLANGE CONNECTIONS

## BOOM NOZZLE PIPE ADAPTER

### FEATURES

- Eliminates having to thread pipe
- Quick and easy assembly
- No welding necessary
- 360° orientation



BOOM NOZZLE PIPE ADAPTER				
PART NO	DESCRIPTION	MAX PSI	LOT QTY	
M100PA	1" FLANGED PIPE ADAPTER	300	10	
M100PAC	1" FLANGED PIPE ADAPTER CAP	300	1	
M100PAT	1" FLANGED PIPE ADAPTER TEE	300	1	

## INDUCTORS

### FEATURES

- Threaded or manifold ends
- Glass reinforced polypropylene
- Designed for use with a volume pump. Typical volumes (80-240 US GPM) and pressures (26-52 PSI) should be used to operate the inductor.



MANIFOLD INDUCTORS					
PART NO	DESCRIPTION	PRESSURE AT PUMP	VOLUME DRAW	OPENING SIZE	LOT QTY
HV200	2" MPT INDUCTOR	225	49 GPM	7/16"	1
MHV200	2" MANIFOLD INDUCTOR WITH 1½" PORT	300	37 GPM	5/16"	1
MHV220A	2" FULL PORT MANIFOLD INDUCTOR	225	49 GPM	9/16"	5

# MANIFOLD FLANGE CONNECTIONS

## INDUCTOR SYSTEMS

### FEATURES

- Installed after pump; suction completely empties inductor tank
- Keeps pump free of chemicals
- Easy assembly/installation with manifold connections found on pages 39-45.
- Choose your connections and valve
- Tank for illustration purposes only, not included

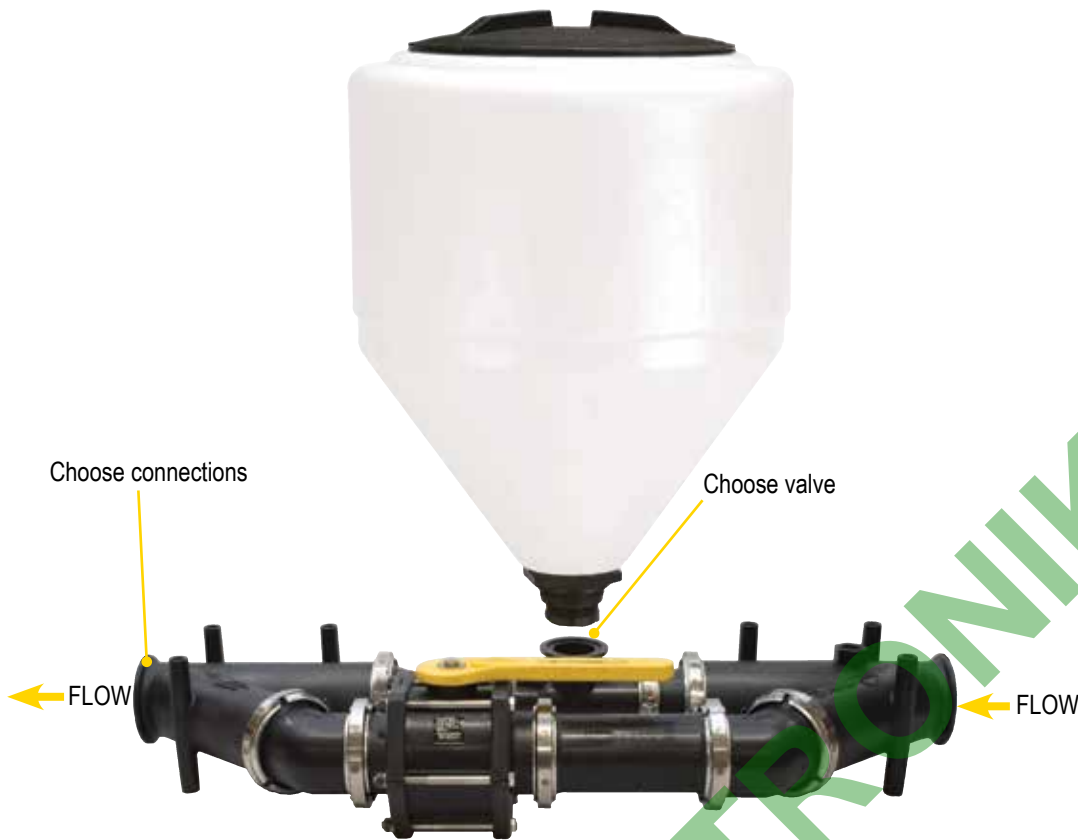

### MANIFOLD INDUCTOR SYSTEMS

PART NO	DESCRIPTION	MAX PSI	QTY
MIS220	2" FULL PORT MANIFOLD INDUCTOR SYSTEM FLANGE X FLANGE ASSEMBLED	225	1
MIS300	3" FULL PORT MANIFOLD INDUCTOR SYSTEM FLANGE X FLANGE ASSEMBLED	150	1

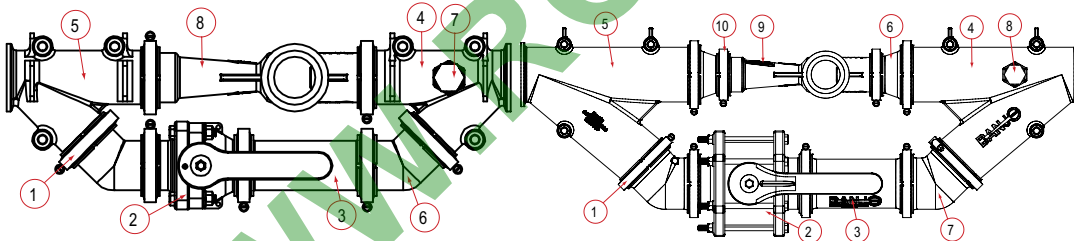

### MANIFOLD INDUCTORS

ITEM	PART NO	DESCRIPTION	LOT QTY
1	FC220	220 SERIES WORM SCREW CLAMP	10/BAG
2	MVS220CF	2" FP FLANGE X 2" FP FLANGE	9
3	M220CPG6	2" X 2" FULL PORT FLANGE X 6"	5
4	M220YG45	2" FULL PORT 45° Y FLANGE W/ 3/4" GAUGE PORT*	1
5	M220Y45	2" FULL PORT 45° Y FLANGE	5
6	M220CPG45	2" FULL PORT 45° COUPLING	10/BAG
7	PLUG075	3/4" PIPE PLUG	10/BAG
8	MHV220A	2" FULL PORT POLY VENTURI	5
N/S	M221G	2" FULL PORT EPDM MANIFOLD GASKET WITH RIB	30

### MANIFOLD INDUCTORS

ITEM	PART NO	DESCRIPTION	LOT QTY
1	FC300	300 SERIES WORM SCREW CLAMP	10/BAG
2	MV301CF	3" FP FLANGE X 3" FP FLANGE	1
3	M300CPG7	3" X 3" FULL PORT FLANGE X 7"	5
4	M300YG45	3" FULL PORT 45° Y FLANGE W/ 3/4" GAUGE PORT*	1
5	M300Y45	3" FULL PORT 45° Y FLANGE	1
6	M300220CPG	3" X 2" FULL PORT REDUCER FLANGE	10
7	M300CPG45	3" FULL PORT 45° COUPLING	10
8	PLUG075	3/4" PIPE PLUG	10/BAG
9	MHV220A	2" FULL PORT POLY VENTURI	5
10	FC220	220 SERIES WORM SCREW CLAMP	10/BAG
N/S	M221G	2" FULL PORT EPDM MANIFOLD GASKET WITH RIB	30
N/S	M301G	3" EPDM MANIFOLD GASKET WITH RIB	50

\*Note: Gauge not included.

# MANIFOLD FLANGE CONNECTIONS

## FLOW METERS

### FEATURES

- Displays overall total volume and batch total volume
- Flow rate allows for Gallons or Liters per minute
- The display reads 6 digits for rate, 8 digits for total and 1 decimal place reading in tenths
- Magnetic style meter with stainless steel electrodes
- Self calibrating meter
- Measures water and most conductive liquids
- Easy to change six (6) AA batteries
- No moving parts to fail during use
- Glass-reinforced polypropylene
- Temperature range from 0°F to 150°F
- ±1% of reading (between 10% and 100% of maximum flow)
- ±3% of reading (between cutoff and 10% of maximum flow)
- There are 3 photoeyes located on the face of the flow meter. These are not push buttons; to activate you must hold your finger over the photoeye for 2-4 seconds
- Flow meters will not read petroleum based liquids
- It is recommended to have at least 10X the diameter of straight pipe before and after the flow meter



FM100



MFM100



MFM220



MFM300

### FLOW METERS

PART NO	DESCRIPTION	MAX PSI	GPM	QTY
FM100	1" FULL PORT FEMALE NPT FLOW METER	200	110 GPM	1
MFM100	1" FULL PORT MANIFOLD FLOW METER	200	110 GPM	1
MFM220	2" FULL PORT MANIFOLD FLOW METER	200	300 GPM	1
MFM300	3" FULL PORT FLOW METER	200	670 GPM	1

# MANIFOLD FLANGE CONNECTIONS



## SWEEPS

### FEATURES

- Direct replacement for standard 90° flanged couplings
- Positive seals
- Quick and easy assembly
- Easy on/off hose connections
- 360° orientation
- Improved flow for max GPM

## SWEEPS

PART NO	DESCRIPTION	MAX PSI	LOT QTY
M100125BRBSWP90	1" FLANGE X 1/4" HOSE BARB SWEEP	300	10/BAG
M100BRBSWP90	1" FLANGE X HOSE BARB SWEEP	300	10/BAG
M100BRBSWPG90	1" FULL PORT FLANGE X 1" HOSE BARB SWEEP W/ 1/4" GAUGE PORT	300	10/BAG
M100SWP90	1" FLANGE X FLANGE SWEEP	300	10/BAG
M100SWPG90	1" FLANGE X FLANGE SWEEP W/ 1/4" GAUGE PORT	300	10/BAG
M200SWP90	2" FLANGE X FLANGE SWEEP	300	10/BAG
M200150BRBSWP90	2" FLANGE X 1/2" HOSE BARB SWEEP	300	10/BAG
M220200SWP90	2" FULL PORT FLANGE X 2" FLANGE SWEEP	300	10/BAG
M220ASWP90	2" FULL PORT FLANGE X MALE ADAPTER SWEEP	200	10/BAG
M220BRBSWP90	2" FULL PORT FLANGE X HOSE BARB SWEEP	300	10
M220MPTSWP90	2" FULL PORT FLANGE X MALE NPT THREAD SWEEP	300	1
M220SWP90	2" FULL PORT FLANGE X FLANGE SWEEP	300	10/BAG
M220SWPG90	2" FULL PORT FLANGE X FLANGE SWEEP W/ 1/4" GAUGE PORT	300	1
M300ASWP90	3" FLANGE X MALE ADAPTER SWEEP	100	1
M300BRBSWP90	3" FLANGE X HOSE BARB SWEEP	225	10
M300MPTSWP90	3" FLANGE X MALE NPT THREAD SWEEP	200	1
M300SWP90	3" FLANGE X FLANGE SWEEP	200	10
M300SWPG90	3" FLANGE X FLANGE SWEEP W/ 1/4" GAUGE PORT	200	1
M300220SWP90	3" FULL PORT FLANGE X 2" FULL PORT FLANGE SWEEP	300	1

# MANIFOLD FLANGE CONNECTIONS

## FITTINGS

### FEATURES

- Quick and easy assembly
- Positive seals
- Easy on/off hose connections
- 360° orientation
- Where noted, parts must be ordered in bag quantities.



### SWIVEL

PART NO	DESCRIPTION	MAX PSI	QTY
MSW220	2" FULL PORT MANIFOLD FLANGE SWIVEL	200	1

### CHECK VALVES

PART NO	DESCRIPTION	OPENING PRESSURE PSI	MAX PSI	LOT QTY
MCV100	1" FLANGED CHECK VALVE	1	300	10
MCV200	2" FLANGED CHECK VALVE	0.5	300	10
MCV221	2" FULL PORT FLANGED CHECK VALVE	>0.5	200	10
MCV300	3" FLANGED CHECK VALVE W/5 LB SPRING	1.5	200	1
MCV301	3" FLANGED CHECK VALVE W/1/2 LB SPRING	>0.5	200	1

### PVC GLUE SOCKET

PART NO	DESCRIPTION	MAX PSI	LOT QTY
M221GSA	2" FULL PORT FLANGE X 2" PVC GLUE SOCKET FITTING	300	10
M301GSA	3" FULL PORT FLANGE X 3" PVC GLUE SOCKET FITTING	300	1

### 316 SS SOCKET WELD

PART NO	DESCRIPTION	MAX PSI	LOT QTY
M100SWFSS	1" FLANGE X 1" SOCKET WELD FITTING	300	10
M200SWFSS	2" FLANGE X 2" SOCKET WELD FITTING	300	1
M220SWFSS	2" FULL PORT FLANGE X 2" SOCKET WELD FITTING	300	10
M220375SWFSS	2" FULL PORT FLANGE X 2" SOCKET WELD FITTING X 3/4"	300	1
M300SWFSS	3" FLANGE X 3" SOCKET WELD FITTING	300	10
M300375SWFSS	3" FLANGE X 3" SOCKET WELD FITTING X 3/4"	300	1

### COUPLINGS

PART NO	DESCRIPTION	MAX PSI	LOT QTY
M100CPG	1" X 1" FLANGE X 2 1/4" LONG	300	10/BAG
M200CPG	2" X 2" FLANGE X 4 1/2" LONG	300	10/BAG
M220CPG	2" X 2" FULL PORT FLANGE X 2 31/32" LONG	300	10/BAG
M220CPG3G	2" X 2" FULL PORT FLANGE X 3" LONG WITH 1/2" GAUGE PORT	225	1
M220CPG6	2" X 2" FULL PORT FLANGE X 6" LONG	300	5
M300CPG	3" X 3" FULL PORT FLANGE X 4" LONG	200	10
M300CPG7	3" X 3" FULL PORT FLANGE X 7" LONG	225	5
M300CPG12	3" X 3" FULL PORT FLANGE X 12" LONG	150	1

### 45° COUPLINGS

PART NO	DESCRIPTION	MAX PSI	LOT QTY
M100CPG45	1" X 1" 45° FLANGE	300	10/BAG
M200CPG45	2" X 2" 45° FLANGE	300	10/BAG
M220CPG45	2" X 2" FULL PORT 45° FLANGE	225	10/BAG
M300CPG45	3" X 3" FULL PORT 45° FLANGE	225	10



# MANIFOLD FLANGE CONNECTIONS



90° COUPLINGS			
PART NO	DESCRIPTION	MAX PSI	LOT QTY
M100CPG90	1" X 1" 90° FLANGE	300	10/BAG
M200CPG90	2" X 2" 90° FLANGE	300	10/BAG
M200CPG90SH	2" X 2" 90° SHORT FLANGE	300	10/BAG
M220CPG90	2" X 2" 90° FULL PORT FLANGE	200	10/BAG
M300CPG90	3" X 3" 90° FULL PORT FLANGE	200	5



45° Y FLANGED COUPLINGS			
PART NO	DESCRIPTION	MAX PSI	LOT QTY
M220Y45	2" FULL PORT 45° Y FLANGE	300	5
M220YG45	2" FULL PORT 45° Y FLANGE W/ 1/4" GAUGE PORT	225	1
M300Y45	3" FULL PORT 45° Y FLANGE	200	1
M300YG45	3" FULL PORT 45° Y FLANGE W/ 1/4" GAUGE PORT	200	1



3" MANIFOLD WYE			
PART NO	DESCRIPTION	MAX PSI	QTY
M300220WYCG	M300 X M220 X M220 X M220 FULL PORT FLANGE WYE W/ 1/4" GAUGE PORT	300	1



REDUCER COUPLINGS			
PART NO	DESCRIPTION	MAX PSI	LOT QTY
M200100CPG	2" X 1" REDUCER FLANGE	300	10/BAG
M220100CPG	2" FULL PORT X 1" REDUCER FLANGE	225	10/BAG
M220200CPG	2" FULL PORT X 2" REDUCER FLANGE	225	10/BAG
M300200CPG	3" X 2" REDUCER FLANGE	225	10/BAG
M300220CPG	3" X 2" FULL PORT REDUCER FLANGE	225	10



TEES			
PART NO	DESCRIPTION	MAX PSI	LOT QTY
M100TEE	1" FLANGED TEE	300	10/BAG
M200100TEE	2" X 1" FLANGED TEE	300	10
M200TEE	2" FLANGED TEE	300	10
M220100TEE	2" FULL PORT FLANGED TEE X 1" FLANGED TEE	225	10
M220200TEE	2" FULL PORT FLANGED TEE X 2" FLANGED TEE	300	10
M220TEE	2" FULL PORT FLANGED TEE	225	10
M300TEE	3" FLANGED TEE	225	10



U BOLTS			
PART NO	DESCRIPTION	MAX PSI	LOT QTY
UB100	100 SERIES MOUNTING U BOLT	N/A	1
UB202	2 SERIES MOUNTING U BOLT	N/A	10
UB220	220 SERIES MOUNTING U BOLT	N/A	10

## FITTINGS

### FEATURES

- Quick and easy assembly
- Positive seals
- Easy on/off hose connections
- 360° orientation
- Where noted, parts must be ordered in bag quantities

# MANIFOLD FLANGE CONNECTIONS

## FITTINGS

### FEATURES

- Quick and easy assembly
- Positive seals
- Easy on/off hose connections
- 360° orientation
- Where noted, parts must be ordered in bag quantities.



### SS BUTT WELD ADAPTER

PART NO	DESCRIPTION	MAX PSI	QTY
M220BWASS	2" FULL PORT STAINLESS STEEL BUTT WELD ADAPTER	300	1

### FEMALE NPT THREAD

PART NO	DESCRIPTION	MAX PSI	LOT QTY
M100050FPT	1" FLANGE X 1/2" FEMALE THREAD	300	10/BAG
M100075FPT	1" FLANGE X 3/4" FEMALE THREAD	300	10/BAG
M100FPT	1" FLANGE X 1" FEMALE THREAD	300	10/BAG
M200FPT	2" FLANGE X 2" FEMALE THREAD	300	10/BAG
M200150FPT	2" FLANGE X 1 1/2" FEMALE THREAD	300	10/BAG
M220FPT	2" FULL PORT FLANGE X 2" FEMALE THREAD	300	10/BAG
M300FPT	3" FLANGE X 3" FEMALE THREAD	200	10/BAG

### MALE THREAD

PART NO	DESCRIPTION	MAX PSI	LOT QTY
M100075MPT	1" FLANGE X 3/4" MALE THREAD	300	10/BAG
M100MPT	1" FLANGE X 1" MALE THREAD	300	10/BAG
M100125MPT	1" FLANGE X 1 1/4" MALE THREAD	300	10/BAG
M200125MPT	2" FLANGE X 1 1/4" MALE THREAD	300	10/BAG
M200150MPT	2" FLANGE X 1 1/2" MALE THREAD	300	10/BAG
M200MPT	2" FLANGE X 2" MALE THREAD	300	10/BAG
M220MPT	2" FULL PORT FLANGE X 2" MALE THREAD	300	10/BAG
M300MPT	3" FLANGE X 3" MALE THREAD	300	10

### 316 SS MALE THREAD

PART NO	DESCRIPTION	MAX PSI	QTY
M100MPTSS	1" FLANGE X 1" MALE THREAD	300	1
M200125MPTSS	2" FLANGE X 1 1/4" MALE THREAD	300	1
M200150MPTSS	2" FLANGE X 1 1/2" MALE THREAD	300	1
M200MPTSS	2" FLANGE X 2" MALE THREAD	300	1
M220150MPTSS	2" FULL PORT FLANGE X 1 1/2" MALE THREAD	300	1
M220MPTSS	2" FULL PORT FLANGE X 2" MALE THREAD	300	1
M300220MPTSS	3" FLANGE X 2" FULL PORT MALE THREAD	300	1
M300MPTSS	3" FLANGE X 3" MALE THREAD	300	1

WWW.ELECTRONIC

# MANIFOLD FLANGE CONNECTIONS

## FITTINGS

### FEATURES

- Quick and easy assembly
- Positive seals
- Easy on/off hose connections
- 360° orientation
- Where noted, parts must be ordered in bag quantities

### PLUGS

PART NO	DESCRIPTION	MAX PSI	LOT QTY
M100PLG	1" FLANGE PLUG	300	10/BAG
M200PLG	2" FLANGE PLUG	300	10/BAG
M220PLG	2" FULL PORT FLANGE PLUG	300	10/BAG
M300PLG	3" FULL PORT FLANGE PLUG	225	10/BAG
M100PLG025	1" FLANGE PLUG WITH ¼" FPT	300	10/BAG
M100PLG050	1" FLANGE PLUG WITH ½" FPT	300	10/BAG
M200PLG025	2" FLANGE PLUG WITH ¼" FPT	225	10/BAG
M200PLG038	2" FLANGE PLUG WITH ⅜" FPT	300	10/BAG
M200PLG050	2" FLANGE PLUG WITH ½" FPT	225	10/BAG
M200PLG075	2" FLANGE PLUG WITH ¾" FPT	225	10/BAG
M200PLG100	2" FLANGE PLUG WITH 1" FPT	225	10/BAG
M220PLG038	2" FULL PORT FLANGE PLUG WITH ⅜" FPT	150	10/BAG
M220PLG075	2" FULL PORT FLANGE PLUG WITH ¾" FPT	225	10/BAG
M300PLG075	3" FLANGE PLUG WITH ¾" FPT	200	10/BAG
M300PLG100	3" FLANGE PLUG WITH 1" FPT	200	1

### FEMALE COUPLER

PART NO	DESCRIPTION	MAX PSI	LOT QTY
M220D	2" FULL PORT FLANGE X 2" FEMALE COUPLER	225	20
M303D	3" FULL PORT FLANGE X 3" FEMALE COUPLER WITH 3 ARMS	225	10

### MALE ADAPTER

PART NO	DESCRIPTION	MAX PSI	LOT QTY
M100A	1" FLANGE X 1" MALE ADAPTER	300	10/BAG
M200A	2" FLANGE X 2" MALE ADAPTER	300	10/BAG
M220A	2" FULL PORT FLANGE X 2" MALE ADAPTER	225	10/BAG
M300A	3" FULL PORT FLANGE X 3" MALE ADAPTER	100	10

### CROSS

PART NO	DESCRIPTION	MAX PSI	LOT QTY
M100CR	1" FLANGED CROSS	300	10/BAG
M200CR	2" FLANGED CROSS	300	10
M220CR	2" FULL PORT FLANGED CROSS	200	10
M300CR	3" FLANGED CROSS	125	5



# MANIFOLD FLANGE CONNECTIONS

## FITTINGS

### FEATURES

- Quick and easy assembly
- Positive seals
- Easy on/off hose connections
- 360° orientation
- Where noted, parts must be ordered in bag quantities.



## HOSE BARB

PART NO	DESCRIPTION	MAX PSI	LOT QTY
M100075BRB	1" FLANGE X 3/4" HOSE BARB	300	10/BAG
M100BRB	1" FLANGE X 1" HOSE BARB	300	10/BAG
M100125BRB	1" FLANGE X 1 1/4" HOSE BARB	300	10/BAG
M200100BRB	2" FLANGE X 1" HOSE BARB	300	10/BAG
M200125BRB	2" FLANGE X 1 1/4" HOSE BARB	300	10/BAG
M200150BRB	2" FLANGE X 1 1/2" HOSE BARB	300	10/BAG
M200BRB	2" FLANGE X 2" HOSE BARB	300	10/BAG
M220100BRB	2" FULL PORT FLANGE X 1" HOSE BARB	300	10/BAG
M220125BRB	2" FULL PORT FLANGE X 1 1/4" HOSE BARB	300	10/BAG
M220150BRB	2" FULL PORT FLANGE X 1 1/2" HOSE BARB	300	10/BAG
M220BRB	2" FULL PORT FLANGE X 2" HOSE BARB	300	10/BAG
M300220BRB	3" FLANGE X 2" FULL PORT HOSE BARB	125	10
M300BRB	3" FLANGE X 3" HOSE BARB	200	10

## 90° HOSE BARB ELBOW

PART NO	DESCRIPTION	MAX PSI	LOT QTY
M100075BRB90	1" FLANGE X 3/4" 90° HOSE BARB	300	10/BAG
M100BRB90	1" FLANGE X 1" 90° HOSE BARB	300	10/BAG
M100125BRB90	1" FLANGE X 1 1/4" 90° HOSE BARB	300	10/BAG
M100150BRB90	1" FLANGE X 1 1/2" 90° HOSE BARB	300	10/BAG
M200100BRB90	2" FLANGE X 1" 90° HOSE BARB	300	10/BAG
M200125BRB90	2" FLANGE X 1 1/4" 90° HOSE BARB	300	10/BAG
M200150BRB90	2" FLANGE X 1 1/2" 90° HOSE BARB	300	10/BAG
M200BRB90	2" FLANGE X 2" 90° HOSE BARB	300	10/BAG
M220150BRB90	2" FULL PORT FLANGE X 1 1/2" 90° HOSE BARB	300	10/BAG
M220BRB90	2" FULL PORT FLANGE X 2" 90° HOSE BARB	300	10/BAG
M300220BRB90	3" FLANGE X 2" 90° FULL PORT HOSE BARB	300	1
M300BRB90	3" FLANGE X 3" 90° HOSE BARB	150	10

## 45° HOSE BARB ELBOW

PART NO	DESCRIPTION	MAX PSI	LOT QTY
M100BRB45	1" FLANGE X 1" 45° HOSE BARB ELBOW	300	10/BAG
M200BRB45	2" FLANGE X 2" 45° HOSE BARB ELBOW	300	10/BAG
M200125BRB45	2" FLANGE X 1 1/4" 45° HOSE BARB ELBOW	300	10/BAG
M200150BRB45	2" FLANGE X 1 1/2" 45° HOSE BARB ELBOW	300	10/BAG
M220BRB45	2" FULL PORT FLANGE X 2" 45° HOSE BARB ELBOW	300	10/BAG
M300BRB45	3" FLANGE X 3" 45° HOSE BARB ELBOW	150	10

## HOSE BARB TEE

PART NO	DESCRIPTION	MAX PSI	LOT QTY
M100050HBT	1" FLANGE X 1/2" HOSE BARB TEE	300	10/BAG
M100075HBT	1" FLANGE X 3/4" HOSE BARB TEE	300	10/BAG
M100100HBT	1" FLANGE X 1" HOSE BARB TEE	300	10/BAG
M220200HBT	2" FULL PORT FLANGE X 2" HOSE BARB TEE	300	10
M300300HBT	3" FLANGE X 3" HOSE BARB TEE	150	10

WWW.ROLT.COM

# MANIFOLD FLANGE CONNECTIONS



Rib keeps gasket in place during assembly.



M302G



M201G



200G



200GV

## BOLTED FLANGE CLAMPS

PART NO	DESCRIPTION	TORQUE	QTY
FC220B	2" FULL PORT BOLTED FLANGE CLAMP	150 IN/LBS	1
FC300B	3" BOLTED FLANGE CLAMP	150 IN/LBS	1

## T-BOLT FLANGE CLAMPS

PART NO	DESCRIPTION	TORQUE	QTY
FC220TB	2" FULL PORT HI-TORQUE T-BOLT FLANGE CLAMP	100 IN/LBS	10/BAG
FC300TB	3" FULL PORT HI-TORQUE T-BOLT FLANGE CLAMP	100 IN/LBS	10/BAG

## FLANGE CLAMPS

PART NO	DESCRIPTION	TORQUE	QTY
FC100	100 SERIES WORM SCREW CLAMP	50-60 IN/LBS	10/BAG
FC200	200 SERIES WORM SCREW CLAMP	90-100 IN/LBS	10/BAG
FC220	220 SERIES WORM SCREW CLAMP	90-100 IN/LBS	10/BAG
FC300	300 SERIES WORM SCREW CLAMP	90-100 IN/LBS	10/BAG

## GASKETS

PART NO	DESCRIPTION	GASKET MATERIAL	LOT QTY
M100G	100 SERIES MANIFOLD GASKET	EPDM	25
M101G	100 SERIES MANIFOLD GASKET WITH RIB	EPDM	35
M102G	1" & 1¼" SKIRTED FLANGE GASKET	EPDM	1
M100GV	100 SERIES GASKET	FKM	25
150G	200 SERIES GASKET	EPDM	25
150GV	200 SERIES GASKET	FKM	25
200G	220 SERIES FULL PORT GASKET	EPDM	25
200GV	220 SERIES FULL PORT GASKET	FKM	25
M201G	200 SERIES MANIFOLD GASKET WITH RIB	EPDM	30
M202G	1½" SKIRTED FLANGE GASKET	EPDM	1
M221G	220 SERIES FULL PORT MANIFOLD GASKET WITH RIB	EPDM	30
M222G	2" SKIRTED FLANGE GASKET	EPDM	1
300G	300 SERIES GASKET	EPDM	25
300GV	300 SERIES GASKET	FKM	25
M301G	300 SERIES MANIFOLD GASKET WITH RIB	EPDM	50
M302G	3" SKIRTED FLANGE GASKET	EPDM	1

## FITTINGS

### FEATURES

- Quick and easy assembly
- Positive seals
- Easy on/off hose connections
- 360° orientation
- Where noted, parts must be ordered in bag quantities

# MANIFOLD FLANGE CONNECTIONS

## 1"-2" T LINE STRAINERS

### FEATURES

- EPDM gaskets
- Poly ribbed 316 stainless steel screens



### 1" FULL PORT MANIFOLD T LINE STRAINERS

PART NO	DESCRIPTION	MAX PSI	QTY
MLST100-30	1" MANIFOLD T STRAINER W/30 MESH SCREEN	300	1
MLST100-50	1" MANIFOLD T STRAINER W/50 MESH SCREEN	300	1
MLST100-80	1" MANIFOLD T STRAINER W/80 MESH SCREEN	300	1
MLST100-100	1" MANIFOLD T STRAINER W/100 MESH SCREEN	300	1

### 2" STANDARD PORT MANIFOLD T LINE STRAINERS

PART NO	DESCRIPTION	MAX PSI	QTY
MLST150-30	2" MANIFOLD T STRAINER W/30 MESH SCREEN	225	1
MLST150-50	2" MANIFOLD T STRAINER W/50 MESH SCREEN	225	1
MLST150-80	2" MANIFOLD T STRAINER W/80 MESH SCREEN	225	1
MLST150-80V	2" MANIFOLD T STRAINER W/80 MESH SCREEN WITH FKM GASKETS	225	1
MLST150-100	2" MANIFOLD T STRAINER W/100 MESH SCREEN	225	1

## 1"-2" Y LINE STRAINERS

### FEATURES

- EPDM gaskets
- Poly ribbed 316 stainless steel screens



### 1" FULL PORT MANIFOLD Y LINE STRAINERS

PART NO	DESCRIPTION	MAX PSI	QTY
MLS100-80	1" MANIFOLD Y STRAINER W/80 MESH SCREEN	225	1



### 2" STANDARD PORT MANIFOLD Y LINE STRAINERS

PART NO	DESCRIPTION	MAX PSI	QTY
MLS200-06	2" MANIFOLD Y STRAINER W/6 MESH SCREEN	225	1
MLS200-12	2" MANIFOLD Y STRAINER W/12 MESH SCREEN	225	1
MLS200-20	2" MANIFOLD Y STRAINER W/20 MESH SCREEN	225	1
MLS200-30	2" MANIFOLD Y STRAINER W/30 MESH SCREEN	225	1
MLS200-50	2" MANIFOLD Y STRAINER W/50 MESH SCREEN	225	1
MLS200-80	2" MANIFOLD Y STRAINER W/80 MESH SCREEN	225	1

WWW.BANJO.COM

# MANIFOLD FLANGE CONNECTIONS

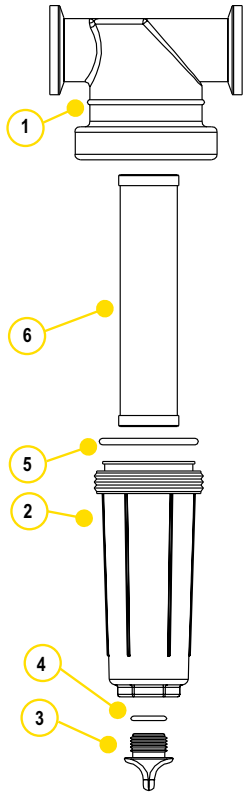

## REPLACEMENT PARTS 1"

ITEM	PART NO	DESCRIPTION	QTY
1	MLST100-H	1" T BODY	1
2	LST100-B	1" T BOWL, DRAIN PLUG, O-RING	1
3	12777	1/2" PLUG	1
4	UV15163	O-RING	1
5	LST100-G	1" EPDM GASKET	1
5	LST100-GV	1" FKM GASKET	1
6	LST116	16 MESH SCREEN	1
6	LST130	30 MESH SCREEN	1
6	LST150	50 MESH SCREEN	1
6	LST180	80 MESH SCREEN	1
6	LST1100	100 MESH SCREEN	1
KIT	MLST100-HB	KIT INCLUDES ITEMS 1-5	1

## REPLACEMENT PARTS 2"

ITEM	PART NO	DESCRIPTION	QTY
1	MLST150-H	1 1/2" T BODY	1
2	LST150-B	1 1/2" T BOWL, DRAIN PLUG, O-RING	1
3	LSQ200-PL	1 1/2" PLUG	1
4	LSQ200-R	O-RING	1
5	LST150-G	1 1/2" EPDM GASKET	1
5	LST150-GV	1 1/2" FKM GASKET	1
6	LST1516	16 MESH SCREEN	1
6	LST1530	30 MESH SCREEN	1
6	LST1550	50 MESH SCREEN	1
6	LST1580	80 MESH SCREEN	1
6	LST15100	100 MESH SCREEN	1
KIT	MLST150-HB	KIT INCLUDES ITEMS 1-5	1

## T LINE STRAINERS

### SCREENS

MESH SIZE	RIB COLOR
16 MESH	BROWN RED
30 MESH	FLAME RED
50 MESH	GENTIAN BLUE
80 MESH	ZINC YELLOW
100 MESH	TRAFFIC GREEN

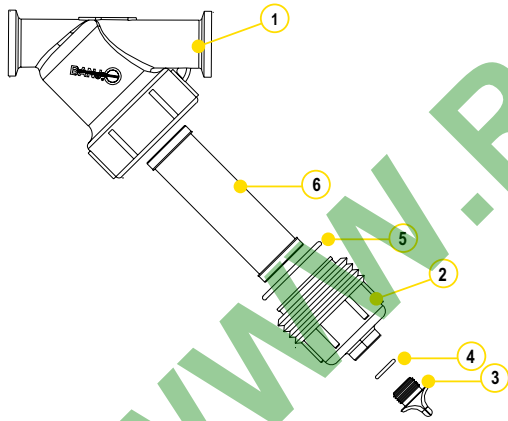

## REPLACEMENT PARTS 1"

ITEM	PART NO	DESCRIPTION	QTY
1	MLS100B	1" Y BODY	1
2	LS100-C1	1" Y BOWL, DRAIN PLUG, O-RING	1
3	12777	1/2" PLUG	1
4	UV15163	O-RING	1
5	LS100-G	1" EPDM GASKET	1
6	LS120	20 MESH SCREEN	1
6	LS140	40 MESH SCREEN	1
6	LS180	80 MESH SCREEN	1
KIT	MLS100BC	KIT INCLUDES ITEMS 1-5	1

## REPLACEMENT PARTS 2"

ITEM	PART NO	DESCRIPTION	QTY
1	MLS200B	2" Y BODY	1
2	LS150-C	2" Y BOWL, DRAIN PLUG, O-RING	1
3	LSQ200-PL	2" PLUG	1
4	LSQ200-R	O-RING	1
5	LS150-G	2" EPDM GASKET	1
5	LS150-GV	2" FKM GASKET	1
6	LS206	6 MESH SCREEN	1
6	LS212	12 MESH SCREEN	1
6	LS220	20 MESH SCREEN	1
6	LS230	30 MESH SCREEN	1
6	LS250	50 MESH SCREEN	1
6	LS280	80 MESH SCREEN	1
6	LS2120	120 MESH SCREEN	1
KIT	MLS200BC	KIT INCLUDES ITEMS 1-5	1

## Y LINE STRAINERS

### SCREENS

MESH SIZE	RIB COLOR
6 MESH	WHITE
12 MESH	BLACK
20 MESH	BEIGE
30 MESH	FLAME RED
40 MESH	BROWN
50 MESH	GENTIAN BLUE
80 MESH	ZINC YELLOW
100 MESH	TRAFFIC GREEN
120 MESH	BLACK

# MANIFOLD FLANGE CONNECTIONS

## 2" FULL PORT Y LINE STRAINERS

### FEATURES

- EPDM gaskets
- 316 stainless steel screens



### 2" FULL PORT MANIFOLD Y LINE STRAINERS

PART NO	DESCRIPTION	MAX PSI	QTY
MLS222-04	2" FULL PORT MANIFOLD Y STRAINER W/4 MESH SCREEN	225	1
MLS222-10	2" FULL PORT MANIFOLD Y STRAINER W/12 MESH SCREEN	225	1
MLS222-16	2" FULL PORT MANIFOLD Y STRAINER W/16 MESH SCREEN	225	1
MLS222-30	2" FULL PORT MANIFOLD Y STRAINER W/30 MESH SCREEN	225	1
MLS222-50	2" FULL PORT MANIFOLD Y STRAINER W/50 MESH SCREEN	225	1
MLS222-80	2" FULL PORT MANIFOLD Y STRAINER W/80 MESH SCREEN	225	1

## 3" Y LINE STRAINERS

### FEATURES

- EPDM gaskets
- 304 stainless steel screens
- Must use on suction side or non-pressure side in all applications



### 3" FULL PORT MANIFOLD Y LINE STRAINERS

PART NO	DESCRIPTION	MAX PSI	LOT QTY
MLS300-12	3" MANIFOLD Y STRAINER W/12 MESH SCREEN	100	1
MLS300-20	3" MANIFOLD Y STRAINER W/20 MESH SCREEN	100	2
MLS300-50	3" MANIFOLD Y STRAINER W/50 MESH SCREEN	100	2



# MANIFOLD FLANGE CONNECTIONS

## 2" FULL PORT Y LINE STRAINERS

### FEATURES

- EPDM gaskets
- 316 stainless steel screens

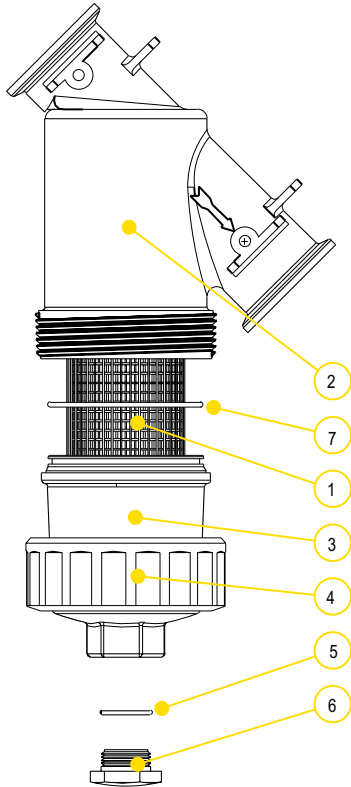

### REPLACEMENT PARTS 2"

ITEM	PART NO	DESCRIPTION	QTY
1	LST204SS	4 SS MESH SCREEN	1
1	LST206SS	6 SS MESH SCREEN	1
1	LST208SS	8 SS MESH SCREEN	1
1	LST210SS	10 SS MESH SCREEN	1
1	LST216SS	16 SS MESH SCREEN	1
1	LST230SS	30 SS MESH SCREEN	1
1	LST250SS	50 SS MESH SCREEN	1
1	MLS250SS	50 SS MESH PERFORATED SCREEN	1
1	LST280SS	80 SS MESH SCREEN	1
1	MLS280SS	80 SS MESH PERFORATED SCREEN	1
1	LST2100SS	100 SS MESH SCREEN	1
1	MLS2100SS	100 SS MESH PERFORATED SCREEN	1
2	MLS222B	2" FLANGED Y STRAINER BODY	1
3	MLS220C1	2" FLANGED Y STRAINER CAP	1
4	MLS220R1	2" FLANGED Y STRAINER RING	1
5	LSQ200-R	2" PLUG GASKET	1
6	LSQ200-PL	2" PLUG	1
7	MLS220G1	2" BODY GASKET	1
2-7	MLS222BC	STRAINER WITHOUT SCREEN	1

## 3" Y LINE STRAINERS

### FEATURES

- EPDM gaskets
- 304 stainless steel screens
- Must use on suction side or non-pressure side in all applications

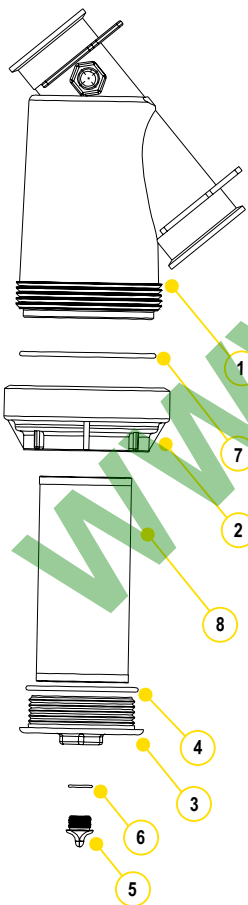

### REPLACEMENT PARTS 3"

ITEM	PART NO	DESCRIPTION	QTY
1	MLS300B	3" FLANGED Y STRAINER BODY	1
2	MLS300CAP	3" FLANGED Y STRAINER CAP	1
3	LS300EC	3" END CAP	1
4	MLS300ECG	3" EPDM END CAP GASKET	1
4	MLS300ECGV	3" FKM END CAP GASKET	1
5	13777	3/4" PLUG	1
6	13778	O-RING	1
7	MLS300G	3" EPDM CAP GASKET	1
8	LS304	4 SS MESH SCREEN	1
8	LS308	8 SS MESH SCREEN	1
8	LS312	12 SS MESH SCREEN	1
8	LS320	20 SS MESH SCREEN	1
8	LS350	50 SS MESH SCREEN	1
1-7	MLS300BC	STRAINER WITHOUT SCREEN	1

# MANIFOLD FLANGE CONNECTIONS

## BOTTOM DRAIN BOLTED TANK FITTINGS

### FEATURES

- Stainless steel bolts
- Bolt head plugs sealed ultrasonically
- Glass reinforced polypropylene
- EDPM gasket standard
- FKM gasket available



### BOTTOM DRAIN BOLTED TANK FITTINGS

PART NO	DESCRIPTION	MAX PSI	LOT QTY
MBF100BD	1" FLANGE X 1" FEMALE THREAD W/EPDM GASKET	150	5
MBF200BD	2" FLANGE X 2" FEMALE THREAD W/EPDM GASKET	150	5
MBF220BD	2" FP FLANGE X 2" FEMALE THREAD W/EPDM GASKET	150	5
MBF300BD	3" FLANGE X 3" FEMALE THREAD W/EPDM GASKET	150	8

## BOTTOM DRAIN BULKHEAD FITTINGS

### FEATURES

- Glass reinforced polypropylene
- EDPM standard
- Groove allows more drainage
- Gasket not included



### BOTTOM DRAIN BULKHEAD FITTINGS

PART NO	DESCRIPTION	HOLE SIZE	MAX PSI	LOT QTY
MTF220BD	2" FP FLANGE X 2" FEMALE THREAD W/EPDM GASKET	3/4"	300	10
MTF300BD	3" FLANGE X 3" FEMALE THREAD W/EPDM GASKET	4 1/2"	200	1

## BOLTED TANK FITTINGS

### FEATURES

- Stainless steel bolts
- Bolt head plugs sealed ultrasonically
- Glass reinforced polypropylene
- EDPM gasket standard
- FKM gasket available



### BOLTED TANK FITTINGS

PART NO	DESCRIPTION	MAX PSI	LOT QTY
MBF100	1" FLANGE X 1" FEMALE THREAD W/EPDM GASKET	150	5
MBF200	2" FLANGE X 2" FEMALE THREAD W/EPDM GASKET	150	5
MBF220	2" FP FLANGE X 2" FEMALE THREAD W/EPDM GASKET	150	5
MBF300	3" FLANGE X 3" FEMALE THREAD W/EPDM GASKET	150	5

WWW.ULTRONIK.PL

## NOT YOUR TYPICAL SPILLAGE

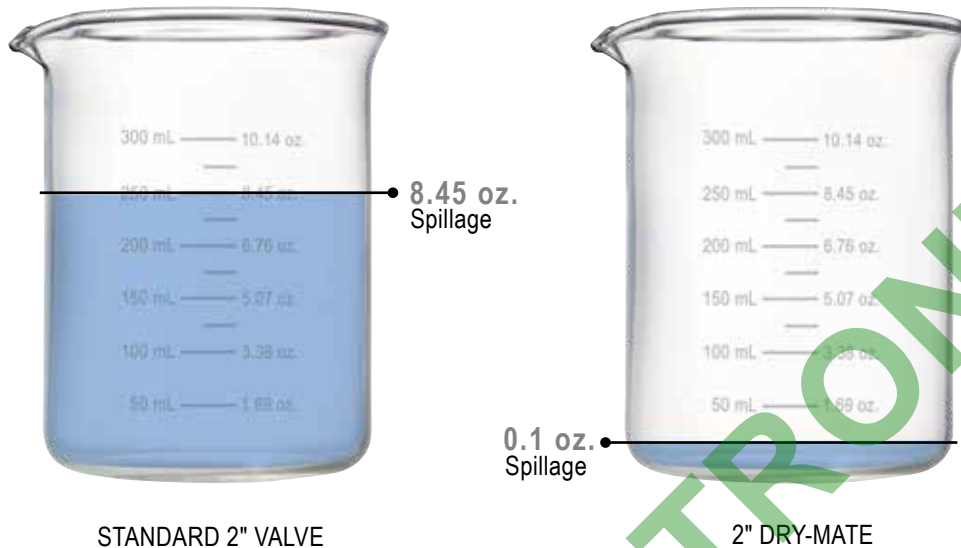

### 99% SPILLAGE REDUCTION

- Reduction of typical spillage using standard 2" valve with cam lock connection vs. Dry-Mate
- 8.45 oz. (250 mL) vs. 0.1 oz. (3 mL) spillage
- At five disconnections per day, this is **over 118 gallons (450 liters) saved per year**; enough to fill the gas tanks of eight mid-size automobiles

### FEATURES



#### SAFETY FIRST

Product is important, but the safety of your team is essential. With Dry-Mate Dry-Disconnects, leakage from disconnecting is miniscule compared to standard valves. When properly installed and operated, the danger posed by harmful chemicals contacting your team is greatly reduced.



#### EVERY DROP COUNTS

Your product is money. Why waste money in spilling your product every time you disconnect? With Dry-Mate, your spillage amount will be significantly reduced. At 3 mL product spillage for a 2" line, you can have peace of mind that your product is being placed where it should be and not on the ground.



#### PRODUCT ONLY WHERE YOU WANT IT

When a Dry-Mate is properly installed and operated, the assembly will not accidentally separate while fluid is flowing; preventing costly mishaps.



#### DITCH THE MAINTENANCE

All that spillage has to go somewhere. If you are collecting large areas of spillage run-off, you have to have it pumped out. Reduce your maintenance costs on your spillage pits by keeping fluids contained.

# DRY-MATES

## 1½" POLY DRY-MATES

### FEATURES

- Lightweight
- Easy to use
- Economical
- Reduces risk of exposure
- Wide range of chemical resistance
- Unrestricted 1½" flow
- Patented double ball design with cam lever connection
- When properly installed and operated, the assembly will not accidentally separate while fluid is flowing; preventing costly mishaps
- Spillage data: 1½" = 2ml



### REPAIR KIT INCLUDES:

- Ball
- Body gasket
- Thrust washer
- Ball seats
- Upper stem bushing
- Stem o-ring

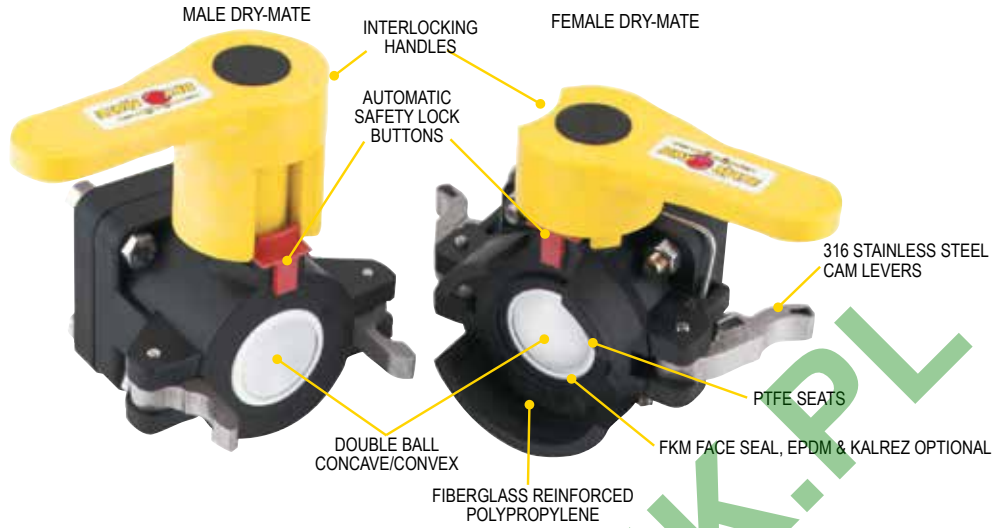

### 1½" POLY MALE DRY-MATE

PART NO	DESCRIPTION	MAX PSI	PIPE SIZE	OPENING THRU BALL	QTY
DM150A	1½" MALE X FPT NPT W/FKM SEALS	100	1½"	1½"	1
DM150AB	1½" MALE X FPT BSP W/FKM SEALS	100	1½"	1½"	1

### 1½" POLY FEMALE DRY-MATE

PART NO	DESCRIPTION	MAX PSI	PIPE SIZE	OPENING THRU BALL	QTY
DM150D	1½" FEMALE X FPT NPT W/FKM SEALS	100	1½"	1½"	1
DM150DB	1½" FEMALE X FPT BSP W/FKM SEALS	100	1½"	1½"	1

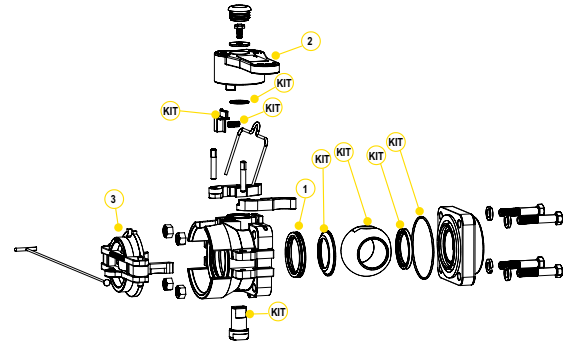
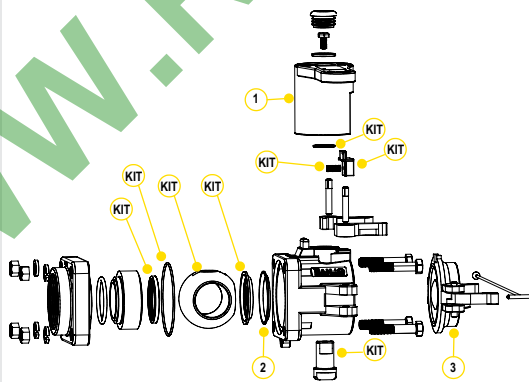

### REPLACEMENT PARTS MALE

ITEM	PART NO	DESCRIPTION	QTY
1	DM20153M	MALE HANDLE	1
1	DB20153M	LOW PROFILE HANDLE	1
2	DB20290	FKM FACE SEAL	1
2	DB20295	EPDM FACE SEAL	1
2	DM20296	KALREZ® FACE SEAL	1
3	DM200CAP	DUST CAP	1
KIT	DM20200A	REPAIR KIT FOR DM150A	1

### REPLACEMENT PARTS FEMALE

ITEM	PART NO	DESCRIPTION	QTY
1	DM20294A	FKM FACE SEAL	1
1	DB20295A	EPDM FACE SEAL	1
1	DM20296	KALREZ® FACE SEAL	1
2	DM20153F	FEMALE HANDLE	1
3	DM200PL	DUST PLUG	1
KIT	DM20200D	REPAIR KIT FOR DM150D	1

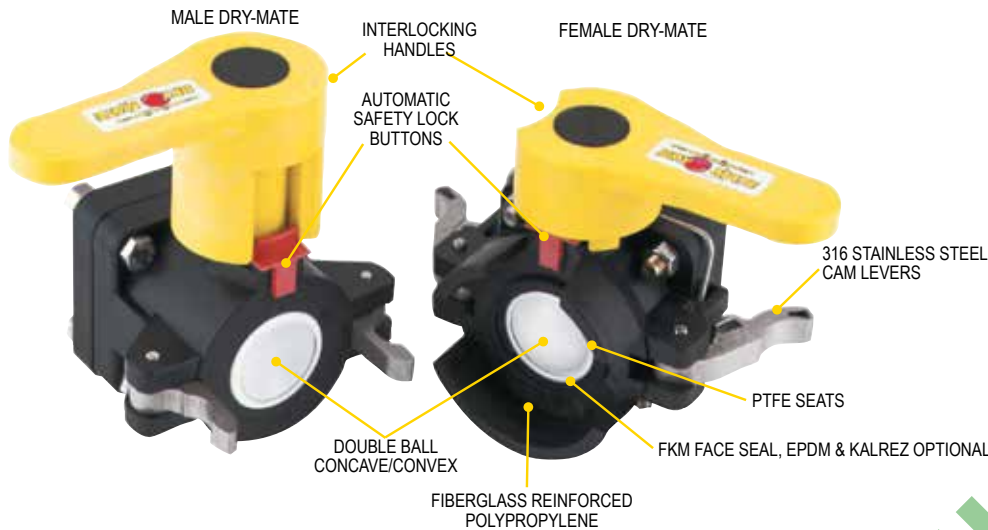

## 2" POLY DRY-MATES

### FEATURES

- Lightweight
- Easy to use
- Economical
- Reduces risk of exposure
- Wide range of chemical resistance
- Unrestricted 1½" flow
- Patented double ball design with cam lever connection
- When properly installed and operated, the assembly will not accidentally separate while fluid is flowing; preventing costly mishaps
- Spillage data: 2" = 2.6ml

### 2" POLY MALE DRY-MATE

PART NO	DESCRIPTION	MAX PSI	PIPE SIZE	OPENING THRU BALL	QTY
DM200A	2" MALE X FPT NPT W/FKM SEALS	100	2"	1½"	1
DM200AB	2" MALE X FPT BSP W/FKM SEALS	100	2"	1½"	1
DM200AE	2" MALE X FPT NPT W/EPDM SEALS	100	2"	1½"	1
DMMT201A	2" MALE X MALE NPT W/LOW PROFILE HANDLE	100	2"	1½"	1

### 2" POLY FEMALE DRY-MATE

PART NO	DESCRIPTION	MAX PSI	PIPE SIZE	OPENING THRU BALL	QTY
DM200D	2" FEMALE X FPT NPT W/FKM SEALS	100	2"	1½"	1
DM200DB	2" FEMALE X FPT BSP W/FKM SEALS	100	2"	1½"	1
DM200DE	2" FEMALE W/EPDM SEALS	100	2"	1½"	1



### REPAIR KIT INCLUDES:

- Ball
- Body gasket
- Thrust washer
- Ball seats
- Upper stem bushing
- Stem o-ring

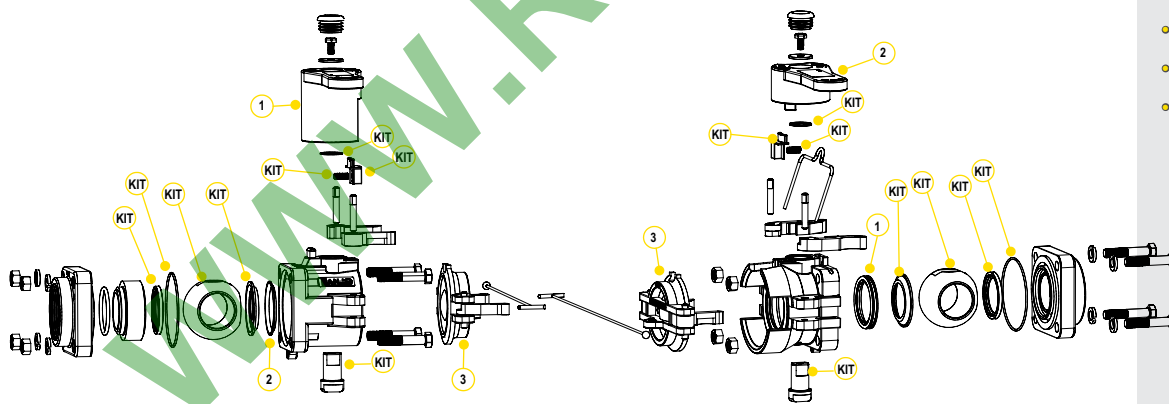

### REPLACEMENT PARTS MALE

ITEM	PART NO	DESCRIPTION	QTY
1	DM20153M	MALE HANDLE	1
1	DB20153M	LOW PROFILE HANDLE	1
2	DB20290	FKM FACE SEAL	1
2	DB20295	EPDM FACE SEAL	1
2	DM20296	KALREZ® FACE SEAL	1
3	DM200CAP	DUST CAP	1
KIT	DM20200A	REPAIR KIT FOR DM200A & DM200AE	1

### REPLACEMENT PARTS FEMALE

ITEM	PART NO	DESCRIPTION	QTY
1	DM20294A	FKM FACE SEAL	1
1	DB20295A	EPDM FACE SEAL	1
1	DM20296	KALREZ® FACE SEAL	1
2	DM20153F	FEMALE HANDLE	1
3	DM200PL	DUST PLUG	1
KIT	DM20200D	REPAIR KIT FOR DM200D & DM200DE	1

# DRY-MATES

## 2" FULL PORT POLY DRY-MATES

### FEATURES

- Lightweight
- Easy to use
- Economical
- Reduces risk of exposure
- Wide range of chemical resistance
- Unrestricted 2" flow
- Patented double ball design with cam lever connection
- When properly installed and operated, the assembly will not accidentally separate while fluid is flowing; preventing costly mishaps
- Spillage data: 2" FP = 3.6ml



### 2" FULL PORT POLY DRY-MATES

PART NO	DESCRIPTION	MAX PSI	PIPE SIZE	OPENING THRU BALL	QTY
DM220D	2" FEMALE X FPT NPT W/FKM SEALS	225	2"	2"	1
DM220A	2" MALE X FPT W/FKM SEALS	225	2"	2"	1



### REPAIR KIT INCLUDES:

- Body gasket
- Thrust washer
- Ball seats
- Upper stem bushing
- Stem o-ring
- Face seal

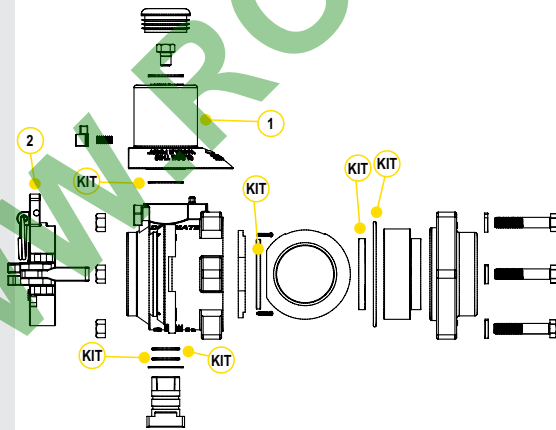

### REPLACEMENT PARTS MALE

ITEM	PART NO	DESCRIPTION	QTY
1	DM25153M	MALE HANDLE	1
2	DM220CAP	DUST CAP	1
KIT	DM25200	REPAIR KIT	1

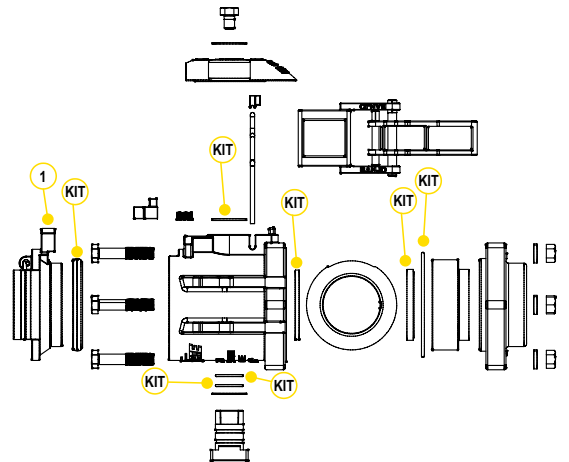

### REPLACEMENT PARTS FEMALE

ITEM	PART NO	DESCRIPTION	QTY
1	DM221PL	DUST PLUG	1
1	DM25200	REPAIR KIT	1

## 3" FULL PORT POLY DRY-MATES

### FEATURES

- Lightweight
- Easy to use
- Economical
- Reduces risk of exposure
- Wide range of chemical resistance
- Unrestricted 3" flow
- Patented double ball design with cam lever connection
- When properly installed and operated, the assembly will not accidentally separate while fluid is flowing; preventing costly mishaps
- Spillage data: 3" = 20ml



### REPAIR KIT INCLUDES:

- Ball
- Body gasket
- Thrust washer
- Ball seats
- Upper stem bushing
- Stem o-ring
- Face seal



DM300DFP



DM300AFP

### 3" FULL PORT POLY DRY-MATES

PART NO	DESCRIPTION	MAX PSI	PIPE SIZE	OPENING THRU BALL	QTY
DM300AFP	3" FP MALE X 3" FEMALE NPT THREADS W/ FKM SEALS	150	3"	3"	1
DM300DFP	3" FP FEMALE X 3" FEMALE NPT THREADS W/ FKM SEALS	150	3"	3"	1

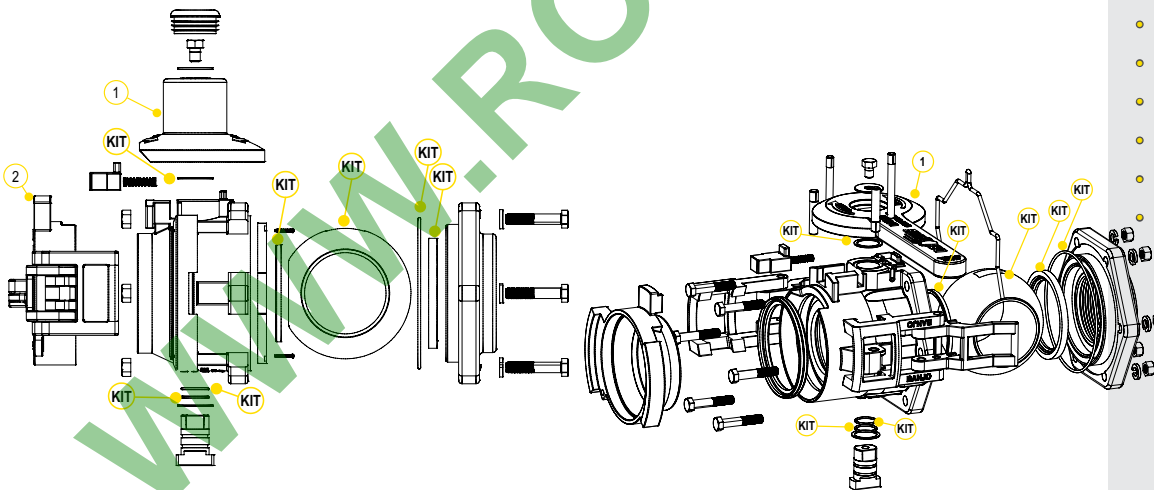

### REPLACEMENT PARTS MALE

ITEM	PART NO	DESCRIPTION	QTY
1	DM35153M	MALE HANDLE	1
2	DM300CAP	DUST CAP	1
KIT	DM35200	REPAIR KIT	1

### REPLACEMENT PARTS FEMALE

ITEM	PART NO	DESCRIPTION	QTY
1	DM35153F	FEMALE HANDLE	1
KIT	DM35200	REPAIR KIT	1

# DRY-MATES

## 1" FULL PORT STAINLESS STEEL DRY-MATES

### FEATURES

- 316 stainless steel construction
- Unrestricted 1" flow
- Patented double ball design with cam lever connection
- 300°F maximum operating temperature
- 100% PTFE ball seats
- When properly installed and operated, the assembly will not accidentally separate while fluid is flowing; preventing costly mishaps
- Spillage data: 1" FP = 1.7ml



DM100ASS

DM100DSS

### 1" FULL PORT STAINLESS STEEL DRY-MATE

PART NO	DESCRIPTION	MAX PSI	PIPE SIZE	OPENING THRU BALL	QTY
DM100ASS	1" MALE X FPT NPT W/ PTFE SEALS	150	1"	1"	1
DM100ABSS	1" MALE X FPT BSP W/ PTFE SEALS	150	1"	1"	1
DM100DSS	1" FEMALE X FPT NPT W/ FKM SEALS	150	1"	1"	1
DM100DSSE	1" FEMALE X FPT NPT W/ EPDM SEALS	150	1"	1"	1
DM100DBSS	1" FEMALE X FPT BSP W/ FKM SEALS	150	1"	1"	1



### REPAIR KIT INCLUDES:

- Ball
- Body gasket
- Thrust washer
- Ball seats
- Upper stem bushing
- Stem o-ring
- Face seal

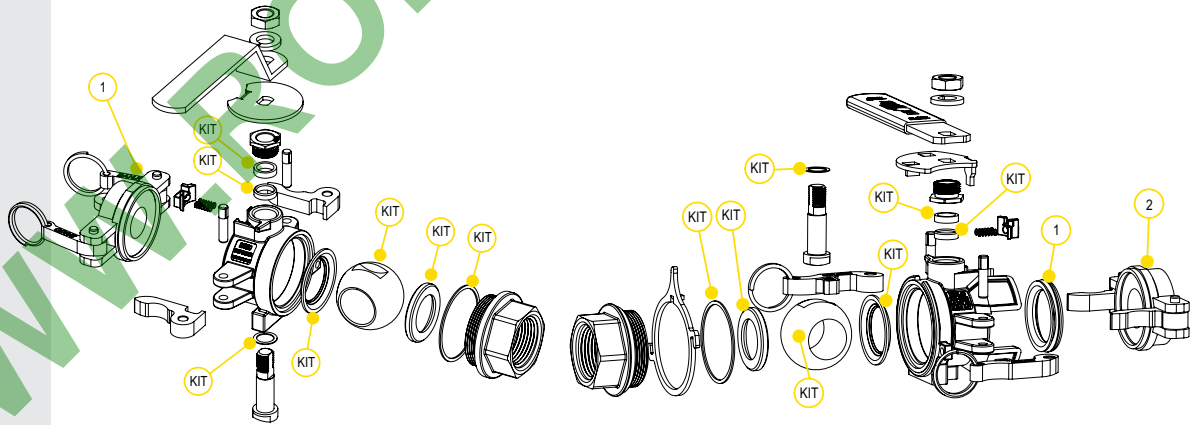

### REPLACEMENT PARTS MALE

ITEM	PART NO	DESCRIPTION	QTY
1	DM100CAP	DUST CAP	1
KIT	DM101SS	REPAIR KIT	1

### REPLACEMENT PARTS FEMALE

ITEM	PART NO	DESCRIPTION	QTY
1	DM10294A	FKM FACE SEAL	1
1	DM10295A	EPDM FACE SEAL	1
1	DM10296	KALREZ® FACE SEAL	1
2	DM100PL	POLY PLUG	1
KIT	DM102SSV	FKM REPAIR KIT	1



## 1½" FULL PORT STAINLESS STEEL DRY-MATES



DM150ASS



DM150DSS

### 1½" FULL PORT STAINLESS STEEL DRY-MATE

PART NO	DESCRIPTION	MAX PSI	PIPE SIZE	OPENING THRU BALL	QTY
DM150ASS	1½" MALE X FPT NPT W/ PTFE SEALS	150	1½"	1½"	1
DM150ABSS	1½" MALE X FPT BSP W/ PTFE SEALS	150	1½"	1½"	1
DM150DSS	1½" FEMALE X FPT NPT W/ FKM SEALS	150	1½"	1½"	1
DM150DSSE	1½" FEMALE X FPT NPT W/ EPDM SEALS	150	1½"	1½"	1
DM150DBSS	1½" FEMALE X FPT BSP W/ FKM SEALS	150	1½"	1½"	1

### FEATURES

- 316 stainless steel construction
- Unrestricted 1½" flow
- Patented double ball design with cam lever connection
- 300°F maximum operating temperature
- 100% PTFE ball seats
- When properly installed and operated, the assembly will not accidentally separate while fluid is flowing; preventing costly mishaps
- Spillage data: 1½" FP = 3ml



### REPAIR KIT INCLUDES:

- Ball
- Body gasket
- Thrust washer
- Ball seats
- Upper stem bushing
- Stem o-ring
- Face seal

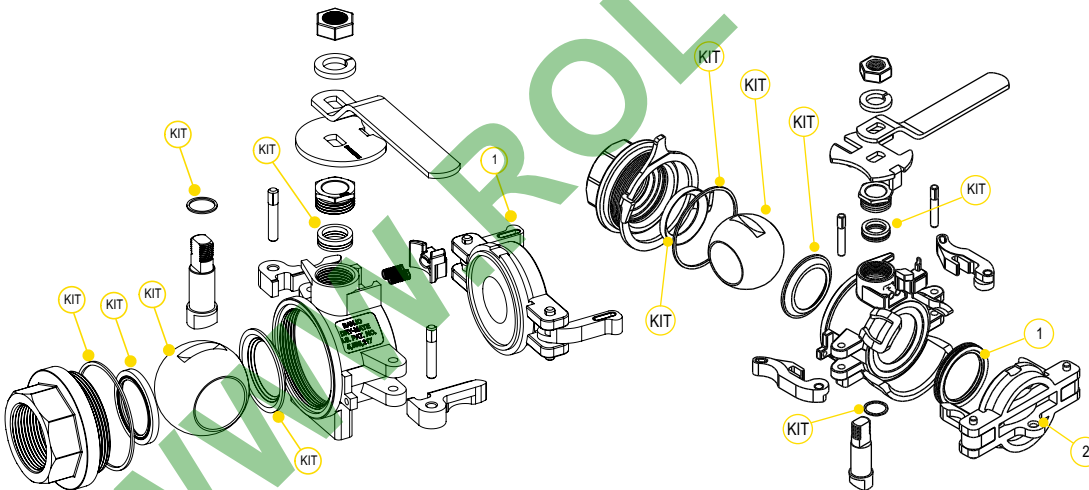

### REPLACEMENT PARTS MALE

ITEM	PART NO	DESCRIPTION	QTY
1	DM200ACAP	DUST CAP	1
KIT	DM201SS	REPAIR KIT	1

### REPLACEMENT PARTS FEMALE

ITEM	PART NO	DESCRIPTION	QTY
1	DM20294A	FKM FACE SEAL	1
1	DB20295	EPDM FACE SEAL	1
1	DM20296	KALREZ® FACE SEAL	1
2	DM200APL	DUST PLUG	1
KIT	DM202SSV	FKM REPAIR KIT	1

# DRY-MATES

## 2" STAINLESS STEEL DRY-MATES

### FEATURES

- 316 stainless steel construction
- Patented double ball design with cam lever connection
- 300°F maximum operating temperature
- 100% PTFE ball seats
- When properly installed and operated, the assembly will not accidentally separate while fluid is flowing; preventing costly mishaps
- Spillage data: 2" = 3.6ml



DM200ASS



DM200DSS

### 2" STANDARD PORT STAINLESS STEEL DRY-MATE

PART NO	DESCRIPTION	MAX PSI	PIPE SIZE	OPENING THRU BALL	QTY
DM200ASS	2" MALE X FPT NPT W/ PTFE SEALS	150	2"	1½"	1
DM200ABSS	2" MALE X FPT BSP W/ PTFE SEALS	150	2"	1½"	1
DM200DSS	2" FEMALE X FPT NPT W/ FKM SEALS	150	2"	1½"	1
DM200DSST	2" FEMALE X FPT NPT W/ KALREZ® SEALS	150	2"	1½"	1
DM200DBSS	2" FEMALE X FPT BSP W/ FKM SEALS	150	2"	1½"	1



### REPAIR KIT INCLUDES:

- Ball
- Body gasket
- Thrust washer
- Ball seats
- Upper stem bushing
- Stem o-ring
- Face seal

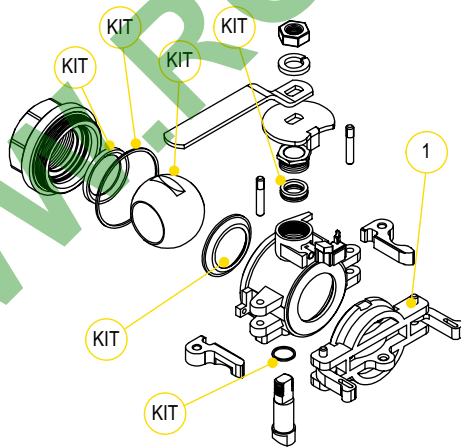

### REPLACEMENT PARTS MALE

ITEM	PART NO	DESCRIPTION	QTY
1	DM200ACAP	DUST CAP	1
KIT	DM201SS	REPAIR KIT	1

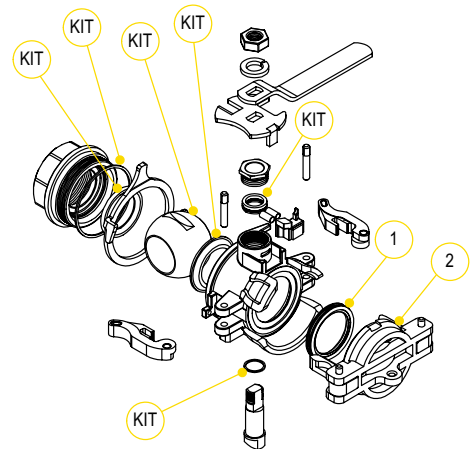

### REPLACEMENT PARTS FEMALE

ITEM	PART NO	DESCRIPTION	QTY
1	DM20294A	FKM FACE SEAL	1
1	DB20295	EPDM FACE SEAL	1
1	DM20296	KALREZ® FACE SEAL	1
2	DM200APL	POLY PLUG	1
KIT	DM202SSV	FKM REPAIR KIT	1

WWW.PROLIFE.COM

## 2" FULL PORT STAINLESS STEEL DRY-MATES



DM220ABSS



DM220DBSS

### 2" FULL PORT STAINLESS STEEL DRY-MATE

PART NO	DESCRIPTION	MAX PSI	PIPE SIZE	OPENING THRU BALL	QTY
DM220ABSS	2" FULL PORT MALE X FPT BSP W/ PTFE SEALS	300	2"	2"	1
DM220DBSS	2" FULL PORT FEMALE X FPT BSP W/ FKM SEALS	300	2"	2"	1

### FEATURES

- 316 stainless steel construction
- Unrestricted 2" flow
- Patented double ball design with cam lever connection
- 300°F maximum operating temperature
- 100% PTFE ball seats
- When properly installed and operated, the assembly will not accidentally separate while fluid is flowing; preventing costly mishaps
- Spillage data: 2" FP = 3.8ml



### REPAIR KIT INCLUDES:

- Body gasket
- Thrust washer
- Ball seats
- Upper stem bushing
- Stem o-ring

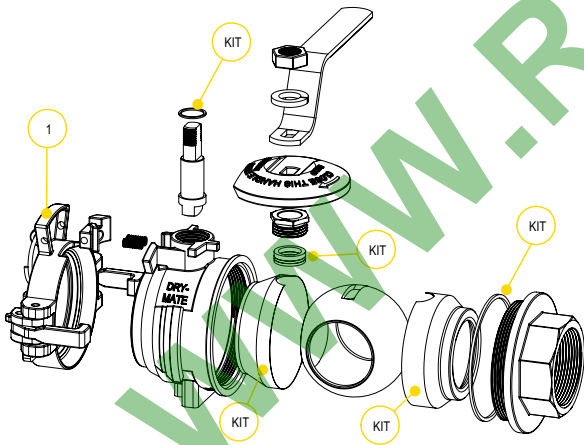

### REPLACEMENT PARTS MALE

ITEM	PART NO	DESCRIPTION	QTY
1	DM220CAP	DUST CAP	1
KIT	DM221SS	REPAIR KIT	1

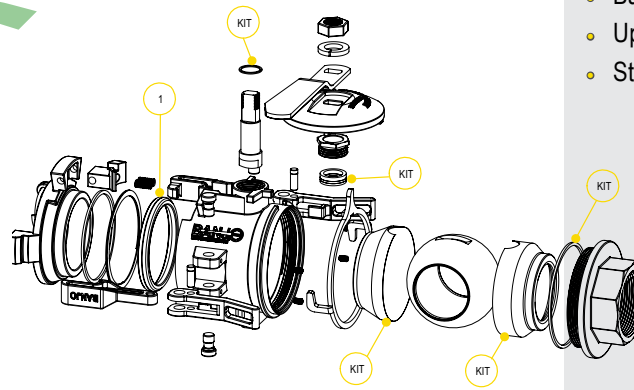

### REPLACEMENT PARTS FEMALE

ITEM	PART NO	DESCRIPTION	QTY
1	DM25294	FKM FACE SEAL	1
1	DM25294T	KALREZ® FACE SEAL	1
KIT	DM222SS	REPAIR KIT	1

# DRY-MATES

## DRY POPPET COUPLINGS

### FEATURES

- Lightweight
- Minimal fluid spillage
- Easy to use
- Economical
- Reduces risk of exposure
- Wide range of chemical resistance
- Maximum operating temperature 150° F
- 30 GPM maximum flow
- Precision molded in polypropylene
- 1" female NPT threads

### APPLICATIONS

- Agriculture
- Industrial
- Pharmaceutical
- Chemical processing

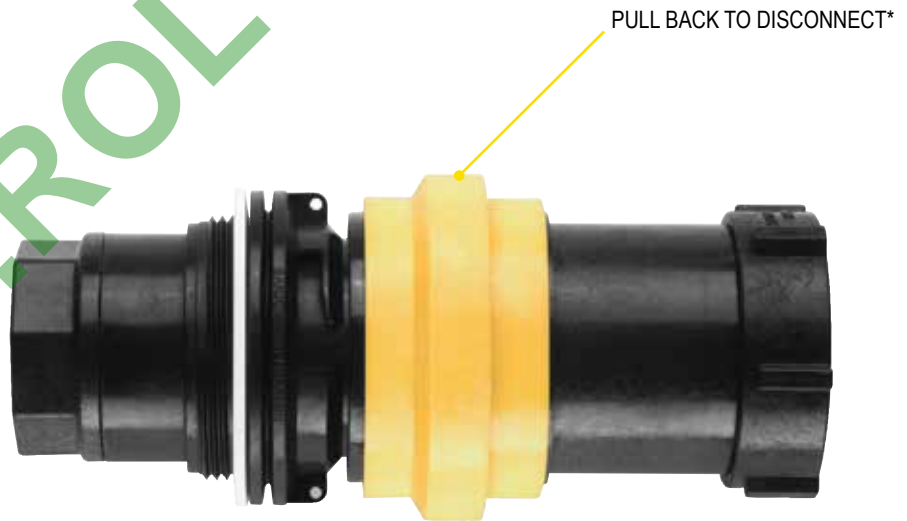

### DRY POPPET COUPLINGS

PART NO	DESCRIPTION	MAX PSI	QTY
DPCF100	FEMALE DRY POPPET COUPLER, 1" FEMALE NPT THREADS W/ FKM SEALS	100	1
DPCM100	MALE DRY POPPET ADAPTER, 1" FEMALE NPT THREADS W/ FKM SEALS	150	1
DPCMT100	MALE DRY POPPET ADAPTER, W/2" MALE THREADED BODY 1" FEMALE NPT THREADS W/ FKM SEALS	150	1

**\*Note:** Male adapter and female coupler shown coupled together but sold separately.

## SPIN WELD BALL VALVES



W230237



W230238



W230239



W230240



WSF210FSA



WSF210FSAV



WSMT210FSA



WSMT210FSAV

Identifying collar number found here

### FEATURES

- PTFE seats
- FKM stem o-rings
- Precision molded polypropylene is reinforced with fiberglass for additional strength
- Zinc alloy collar
- FKM, EPDM and Santoprene collar gaskets available
- Handles close in either direction
- For faster shipping, order in box quantities

### SPINWELD BALL VALVE

PART NO	DESCRIPTION	GASKET MATERIAL	COLLAR FITS	COLLAR NUMBER	COLLAR ID	MAX PSI	QTY
W230237	2" POLY SPINWELD VALVE W/NPT OUTLET & CAP & FOIL SEAL	FKM	MAUSER®	V22283 C & D	2 1/4"	20	1
W230238	2" POLY SPINWELD VALVE W/QDC OUTLET & CAP & FOIL SEAL	FKM	MAUSER®	V22283 C & D	2 1/4"	20	1
W230239	2" POLY SPINWELD VALVE W/NPT OUTLET & CAP & FOIL SEAL	EPDM	MAUSER®	V22283 C & D	2 1/4"	20	1
W230240	2" POLY SPINWELD VALVE W/QDC OUTLET & CAP & FOIL SEAL	EPDM	MAUSER®	V22283 C & D	2 1/4"	20	1
WSF210FSA	2" POLY SPINWELD VALVE W/QDC OUTLET, FOIL SEAL & CAP	SANTOPRENE	SCHUTZ®	V20280 A & B	2 3/4"	50	1
WSF210FSAV	2" POLY SPINWELD VALVE W/QDC OUTLET, FOIL SEAL & CAP	FKM	SCHUTZ®	V20280 A & B	2 3/4"	50	1
WSMT210FSA	2" POLY SPINWELD VALVE W/NPT OUTLET, FOIL SEAL & CAP	SANTOPRENE	SCHUTZ®	V20280 A & B	2 3/4"	225	1
WSMT210FSAV	2" POLY SPINWELD VALVE W/NPT OUTLET, FOIL SEAL & CAP	FKM	SCHUTZ®	V20280 A & B	2 3/4"	225	1

# IBC/TANK ACCESSORIES

## FDA UNION VALVE AND ADAPTERS

### FEATURES

- Precision molded in glass reinforced polypropylene for strength and chemical resistance
- PTFE seats or smooth operation and proper sealing characteristics
- Double EPDM o-rings in stem area for extra sealing protection
- Interlocking body and end plate to allow easy thread connection when installing valves



MBP200



NIP2101



UV204FFPD

### UNION VALVE AND ADAPTERS

PART NO	DESCRIPTION	MAX PSI	QTY
MBP200	2" BUTTRESS X 2" NPT ASSEMBLY	200	1
NIP2101	2" NPT X BSP NIPPLE	300	1
UV204FFPD	2" FDA UNION VALVE WITH EPDM	225	1

WWW.ROLTRONIK.PL

# IBC/TANK ACCESSORIES



## IBC SOLID TANK LIDS

PART NO	DESCRIPTION	GASKET	LOT QTY
TL650S	6" SOLID TANK LID W/GASKET	SANTOPRENE	10

## IBC TANK LID WITH UNVENTED PLUG

PART NO	DESCRIPTION	GASKET	LOT QTY
TL651S	6" TANK LID W/ UNVENTED 2" PLUG W/GASKET	SANTOPRENE	10

## IBC TANK LIDS WITH VENTED PLUG

PART NO	DESCRIPTION	GASKET	QTY
TL652S	6" TANK LID W/ VENTED 2" PLUG W/GASKET	SANTOPRENE	1
TL652E	6" TANK LID VENTED 2" PLUG W/GASKET	EPDM	1

## TANK LID FOR SPRAY TANKS

PART NO	DESCRIPTION	GASKET	QTY
TL600C	6" VENTED TANK LID	N/A	1

## VENTED TANK LIDS

PART NO	DESCRIPTION	GASKET	QTY
TLVA10	10" VENTED TANK LID & RING ASSEMBLY (NEW STYLE)	N/A	1

## SIPHON TUBES

PART NO	DESCRIPTION	LOT QTY
ST200	2" POLY SIPHON TUBE	5
ST300	3" POLY SIPHON TUBE	5

## TANK LIDS

### FEATURES

- Maximum air flow through vent channels
- Airflow equivalent to a 3" hole
- No secondary venting needed
- Baffled vents
- Center vent goes in underside of lid
- NPT Threads

## SIPHON TUBES

### FEATURES

- Full flow size
- Long length
- Male NPT threads
- Made of polypropylene

# IBC/TANK ACCESSORIES

## POLYPROPYLENE ACCESSORIES

### FEATURES

- Glass reinforced polypropylene



### BUTTRESS BY MALE ADAPTER

PART NO	DESCRIPTION	GASKET	PSI	LOT QTY
TA283	2" BUTTRESS X 2" MALE NPT THREADS W/GASKET	SANTOPRENE	300	10
TA283QD	2" BUTTRESS X 2" MALE ADAPTER QDC W GASKET	SANTOPRENE	150	10



### CAPS

PART NO	DESCRIPTION	PSI	QTY
201FPT	2" FEMALE NPT CAP - BLACK	20	1
211FPT	2" FEMALE NPT CAP - YELLOW	20	1



### BUNG PLUGS

PART NO	DESCRIPTION	QTY
231MPT	2" MPT SOLID BUNG W/ EPDM GASKET	1
TL6531	2" VENTED PLUG W/ EPDM GASKET	1



200CAP



200CAPSH



201CAPSH



202CAP



V20207

### DUST CAPS & LANYARD

PART NO	DESCRIPTION	PSI	LOT QTY
200CAP	2" CAM LEVER DUST CAP	200	20
200CAPSH	2" CAM LEVER DUST CAP WITH SHORT ARMS	200	10
201CAPSH	2" CAM LEVER DUST CAP W/SHORT ARMS & RINGS	200	10
202CAP	2" CAM LEVER DUST CAP	20	10
V20207	11" POLYURETHANE LANYARD	N/A	1



## BOLTED TANK FLANGES



BF150



BF300



### BOLTED TANK FLANGES

PART NO	DESCRIPTION	PSI	LOT QTY
BF075	¾" X 1" THREADED FLANGE W/EPDM GASKET	150	10
BF100	1" X 1" THREADED FLANGE W/EPDM GASKET	150	10
BF150	1½" X 2" THREADED FLANGE W/EPDM GASKET	150	5
BF200	2" X 2" THREADED FLANGE W/EPDM GASKET	150	10
BF200V	2" X 2" THREADED FLANGE W/FKM GASKET	150	10
BF220	2" X 2" FP THREADED FLANGE W/EPDM GASKET	150	5
BF300	3" X 3" THREADED FLANGE W/EPDM GASKET	150	4

### FEATURES

- Stainless steel bolts
- Bolt head plugs ultrasonically sealed
- Glass reinforced polypropylene
- EPDM gaskets standard and FKM available
- **WARNING:** Do not tighten tank flange bolts more than 12 ft pounds

### BOLTED TANK FLANGE GASKETS

PART NO	DESCRIPTION	PSI	QTY
BF100GE	1" EPDM GASKET	N/A	1
BF200GE	1½" & 2" EPDM GASKET	N/A	1
BF200GV	1½" & 2" FKM GASKET	N/A	1
BF220GE	2" FULL PORT EPDM GASKET	N/A	1
BF220GV	2" FULL PORT FKM GASKET	N/A	1
BF300GE	3" EPDM GASKET	N/A	1
BF300GV	3" FKM GASKET	N/A	1

¾" — 2"

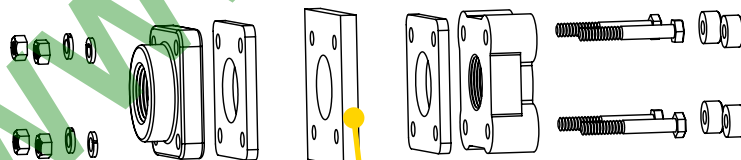

Tank Wall

3"

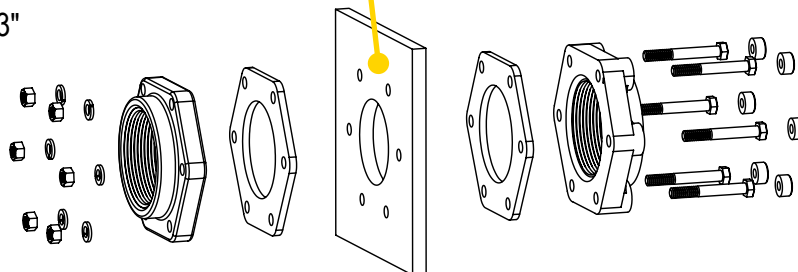

# IBC/TANK ACCESSORIES

## BOLTED BOTTOM DRAIN TANK FLANGES

### FEATURES

- Stainless steel bolts
- Bolt head plugs ultrasonically sealed
- Glass reinforced polypropylene
- EPDM gaskets standard and FKM available
- Allows 100% rinse free
- No sediment build up
- Excellent for avoiding herbicide cross contamination
- Fits most cone bottom and chemical inductor tanks, 30 gallons and larger.
- For faster shipping, order in box quantities



### BOLTED TANK FLANGES

PART NO	DESCRIPTION	MAX PSI	LOT QTY
BF075BD	3/4" X 1" THREADED POLY FLANGE W/ EPDM GASKET	150	5
BF100BD	1" X 1" THREADED POLY FLANGE W/EPDM GASKET	150	5
BF150BD	1 1/2" X 2" THREADED POLY FLANGE W/EPDM GASKET	150	5
BF200BD	2" X 2" THREADED POLY FLANGE W/EPDM GASKET	150	5
BF220BD	2" X 2" FULL PORT THREADED POLY FLANGE W/EPDM GASKET	150	5
BF300BD	3" X 3" THREADED POLY FLANGE W/EPDM GASKET	150	4

### BOLTED TANK FLANGE GASKETS

PART NO	DESCRIPTION	MAX PSI	QTY
BF100GE	3/4", 1" & 1 1/4" EPDM GASKET	N/A	1
BF100GRE	3/4", 1" & 1 1/4" FOOT EPDM GASKET	N/A	1
BF100GRV	3/4", 1" & 1 1/4" FOOT FKM GASKET	N/A	1
BF200GE	1 1/2" & 2" EPDM GASKET	N/A	1
BF200GV	1 1/2" & 2" FKM GASKET	N/A	1
BF200GFV	1 1/2" & 2" STD. PORT. 2" FULL PORT FOOT FKM GASKET	N/A	1
BF220GE	2" FULL PORT EPDM GASKET	N/A	1
BF220GV	2" FULL PORT FKM GASKET	N/A	1
BF300GE	3" EPDM GASKET	N/A	1
BF300GV	3" FKM GASKET	N/A	1
BF300GFE	3" FOOT EPDM GASKET	N/A	1
BF300GFV	3" FOOT FKM GASKET	N/A	1

WWW.BANJO.COM

## BULKHEAD TANK FITTINGS



### POLY BULKHEAD FITTINGS

PART NO	DESCRIPTION	HOLE SIZE	MAX PSI	LOT QTY
TF050	1/2" POLY BULKHEAD TANK FITTING W/EPDM GASKET	1 5/8"	300	10/BAG
TF075	3/4" POLY BULKHEAD TANK FITTING W/EPDM GASKET	1 5/8"	300	10/BAG
TF075V	3/4" POLY BULKHEAD TANK FITTING W/FKM GASKET	1 5/8"	300	10
TF100	1" POLY BULKHEAD TANK FITTING W/EPDM GASKET	2 1/4"	300	10/BAG
TF125	1 1/4" POLY BULKHEAD TANK FITTING W/EPDM GASKET	2 1/4"	300	10
TF150	1 1/2" POLY BULKHEAD TANK FITTING W/EPDM GASKET	3"	300	10
TF200	2" POLY BULKHEAD TANK FITTING W/EPDM GASKET	3"	300	10
TF200V	2" POLY BULKHEAD TANK FITTING W/FKM GASKET	3"	300	10
TF220	2" POLY BULKHEAD TANK FITTING W/EPDM GASKET	3 1/4"	300	10
TF300	3" POLY BULKHEAD TANK FITTING W/EPDM GASKET	4 1/2"	300	5
TF400	4" POLY BULKHEAD TANK FITTING W/EPDM GASKET	5 3/4"	225	5

### FEATURES

- Double sided female NPT threads
- Available with EPDM or FKM gasket
- Where noted, parts must be ordered in bag quantities



### 316 STAINLESS STEEL BULKHEAD FITTINGS

PART NO	DESCRIPTION	HOLE SIZE	MAX PSI	QTY
TF038SS	3/8" SS BULKHEAD TANK FITTING W/EPDM GASKET	1"	300	1
TF050SS	1/2" SS BULKHEAD TANK FITTING W/EPDM GASKET	1 3/8"	300	1
TF075SS	3/4" SS BULKHEAD TANK FITTING W/EPDM GASKET	1 5/8"	300	1
TF100SS	1" SS BULKHEAD TANK FITTING W/EPDM GASKET	2 1/4"	300	1
TF125SS	1 1/4" SS BULKHEAD TANK FITTING W/EPDM GASKET	2 1/4"	300	1
TF150SS	1 1/2" SS BULKHEAD TANK FITTING W/EPDM GASKET	3"	300	1
TF200SS	2" SS BULKHEAD TANK FITTING W/EPDM GASKET	3"	300	1
TF220SS	2" SS BULKHEAD TANK FITTING W/EPDM GASKET	3 1/4"	300	1
TF300SS	3" SS BULKHEAD TANK FITTING W/EPDM GASKET	4 3/8"	300	1

### BULKHEAD GASKETS

PART NO	DESCRIPTION	HOLE SIZE	FITS POLY	FITS SS	LOT QTY
100G	3/8" Poly Bulkhead EPDM Gasket	1"		TF038SS	25
100GV	3/8" Poly Bulkhead FKM Gasket	1"		TF038SS	25
TF138GV	1/2" Poly Bulkhead FKM Gasket	1 3/8"		TF050SS	1
150G	1/2" & 3/4" Poly Bulkhead EPDM Gasket	1 5/8"	TF050 & TF075	TF075SS	25
150GV	1/2" & 3/4" Poly Bulkhead FKM Gasket	1 5/8"	TF050 & TF075	TF075SS	25
300G	1 1/2" & 2" Poly Bulkhead EPDM Gasket	3"	TF200 & TF150	TF200SS & TF150SS	25
300GV	1 1/2" & 2" Poly Bulkhead FKM Gasket	3"	TF200 & TF150	TF200SS & TF150SS	25
TF220G	2" Poly Bulkhead EPDM Gasket	3 1/4"	TF220	TF220SS	1
TF300G	3" Poly Bulkhead EPDM Gasket	4 1/2"	TF300	TF300SS	1
TF400G	4" Poly Bulkhead EPDM Gasket	5 3/4"	TF400		1
TF400GV	4" Poly Bulkhead FKM Gasket	5 3/4"	TF400		1

# IBC/TANK ACCESSORIES

## ANTI VORTEX VENT CAPS

### FEATURES

- Male NPT
- Glass reinforced polypropylene
- 304 stainless steel screen



### ANTI VORTEX VENT CAPS

PART NO	DESCRIPTION	BORE SIZE	BORE AREA	VENT AREA	LOT QTY
VC200	2" ANTI VORTEX VENT CAP WITHOUT SCREEN	2"	3.1 SQ IN	3.9 SQ IN	10
VC230	2" ANTI VORTEX VENT CAP W/12 MESH SS SCREEN	2"	3.1 SQ IN	3.9 SQ IN	10
VC300	3" ANTI VORTEX VENT CAP WITHOUT SCREEN	3"	7 SQ IN	9 SQ IN	10
VC330	3" ANTI VORTEX VENT CAP W/10 MESH SS SCREEN	3"	7 SQ IN	9 SQ IN	1

## ANTI VORTEX TANK FLANGES

### FEATURES

- Standard with FKM
- Prevents swirl in bottom of tank



### ANTI VORTEX TANK FLANGES

PART NO	DESCRIPTION	HOLE SIZE	QTY
TF100AV	1" ANTI VORTEX TANK FLANGES	2 1/4"	1
TF125AV	1 1/4" ANTI VORTEX TANK FLANGES	2 1/4"	1
TF150AV	1 1/2" ANTI VORTEX TANK FLANGES	3"	1
TF200AV	2" ANTI VORTEX TANK FLANGES	3"	1

## ANSI FLANGES

### FEATURES

- Glass reinforced polypropylene
- Heavy duty



### THREADED ANSI FLANGES

PART NO	DESCRIPTION	LOT QTY
AF100	1" FEMALE THREADED ANSI FLANGE	10/BAG
AF150	1½" FEMALE THREADED ANSI FLANGE	10/BAG
AF200	2" FEMALE THREADED ANSI FLANGE	10
AF300	3" FEMALE THREADED ANSI FLANGE	5
AF400	4" FEMALE THREADED ANSI FLANGE	5



### BLIND ANSI FLANGES

PART NO	DESCRIPTION	LOT QTY
AFB200	2" BLIND ANSI FLANGE	10/BAG
AFB300	3" BLIND ANSI FLANGE	5



### ANSI FLANGE GASKETS

PART NO	DESCRIPTION	QTY
AF100G	1" ANSI FLANGE EPDM GASKET	1
AF100GV	1" ANSI FLANGE FKM GASKET	1
AF150G	1½" ANSI FLANGE EPDM GASKET	1
AF200G	2" ANSI FLANGE EPDM GASKET	1
AF200GV	2" ANSI FLANGE FKM GASKET	1
AF300G	3" ANSI FLANGE EPDM GASKET	1
AF300GV	3" ANSI FLANGE FKM GASKET	1
AF400G	4" ANSI FLANGE EPDM GASKET	1
AF400GV	4" ANSI FLANGE FKM GASKET	1



# CAM LEVER COUPLINGS

## 1/4"-4" POLYPROPYLENE

### FEATURES

- Stainless steel rings, arms and pins
- Versatile — interchangeable with all types of cam lever couplings
- Precision molded — ensures a uniform and accurate fit
- Durable — polypropylene is glass reinforced for rugged strength
- Smooth operating — finger rings are designed for easy opening of cam levers
- Economical and superior in performance
- Where noted, parts must be ordered in bag quantities
- 1/4" and 1/2" series couplings interchange with 3/4" size couplings. Coupling ends are 3/4" size.
- 1 1/4" series couplings interchange with 1" size couplings. Coupling ends are 1" size.
- 1 1/2" x 1 1/4" couplings interchange with 1 1/2" size couplings. Coupling ends are 1 1/2" size.



### POLYPROPYLENE CAM LEVER COUPLINGS

ITEM	DESCRIPTION	1/4"	1/2"	3/4"	1"	1 1/4"	1 1/2" x 1 1/4"	1 1/2"	2"	2 1/2"	3"	3" 3 ARMS	4" 3 ARMS
A	MALE ADAPTER X FEMALE THREAD	75A1/4	75A1/2	75A3/4	100A	125A	150125A	150A	200A		300A		400A
B	FEMALE COUPLER X MALE THREAD		75B1/2	75B3/4	100B	125B	150125B	150B	200B		300B	303B	400B
C	FEMALE COUPLER X HOSE BARB		050C	075C	100C	125C	150125C	150C	200C		300C	303C	400C
D	FEMALE COUPLER X FEMALE THREAD		050D	075D	100D	125D	150125D	150D	200D		300D		400D
E	MALE ADAPTER X HOSE BARB		050E	075E	100E	125E	150125E	150E	200E		300E		400E
F	MALE ADAPTER X MALE THREAD		050F	075F	100F	125F	150125F	150F	200F		300F		400F
PL	PLUG FOR FEMALE COUPLER		75PL	75PL	100125PL	100125PL	150PL	150PL	200PL		300PL		400PL
CAP	CAP FOR MALE ADAPTER		075CAP	075CAP	100125CAP	100125CAP	150CAP	150CAP	200CAP	250CAP	300CAP		400CAP (2 arms)
CAPSH	CAP WITH SHORT ARMS						200CAPSH						

### 1/4" SERIES POLY CAM LEVER COUPLINGS

PART NO	DESCRIPTION	MAX PSI	GASKET	LOT QTY
75A1/4	3/4" MALE ADAPTER X 1/4" FEMALE THREAD	300	N/A	10/BAG

### 1/2" SERIES POLY CAM LEVER COUPLINGS

PART NO	DESCRIPTION	MAX PSI	GASKET	LOT QTY
75A1/2	3/4" MALE ADAPTER X 1/2" FEMALE THREAD	225	N/A	10/BAG
75B1/2	3/4" FEMALE COUPLER X 1/2" MALE THREAD	300	EPDM	10/BAG
050C	3/4" FEMALE COUPLER X 1/2" HOSE BARB	300	EPDM	10/BAG
050D	3/4" FEMALE COUPLER X 1/2" FEMALE THREAD	300	EPDM	10/BAG
050E	3/4" MALE ADAPTER X 1/2" HOSE BARB	300	N/A	10/BAG
050F	3/4" MALE ADAPTER X 1/2" MALE THREAD	300	N/A	10/BAG
075CAP	3/4" CAP X MALE ADAPTER	300	EPDM	10/BAG
75PL	3/4" PLUG X FEMALE COUPLER	300	N/A	10/BAG



**WARNING!** Couplings should not be disconnected under pressure or with liquid in the line.

# CAM LEVER COUPLINGS

## 3/4" SERIES POLY CAM LEVER COUPLINGS

PART NO	DESCRIPTION	MAX PSI	GASKET	LOT QTY
75A3/4	3/4" MALE ADAPTER X 3/4" FEMALE THREAD	225	N/A	10/BAG
75B3/4	3/4" FEMALE COUPLER X 3/4" MALE THREAD	300	EPDM	10/BAG
075C	3/4" FEMALE COUPLER X 3/4" HOSE BARB	300	EPDM	10/BAG
075D	3/4" FEMALE COUPLER X 3/4" FEMALE THREAD	300	EPDM	10/BAG
075E	3/4" MALE ADAPTER X 3/4" HOSE BARB	300	N/A	10/BAG
075F	3/4" MALE ADAPTER X 3/4" MALE THREAD	300	N/A	10/BAG
075CAP	3/4" CAP X MALE ADAPTER	300	EPDM	10/BAG
75PL	3/4" PLUG X FEMALE COUPLER	300	N/A	10/BAG

## 1" SERIES POLY CAM LEVER COUPLINGS

PART NO	DESCRIPTION	MAX PSI	GASKET	LOT QTY
100A	1" MALE ADAPTER X 1" FEMALE THREAD	300	N/A	10/BAG
100B	1" FEMALE COUPLER X 1" MALE THREAD	300	EPDM	10/BAG
100C	1" FEMALE COUPLER X 1" HOSE BARB	300	EPDM	10/BAG
100D	1" FEMALE COUPLER X 1" FEMALE THREAD	300	EPDM	10/BAG
100E	1" MALE ADAPTER X 1" HOSE BARB	300	N/A	10/BAG
100F	1" MALE ADAPTER X 1" MALE THREAD	300	N/A	10/BAG
100125CAP	1" CAP X MALE ADAPTER	300	EPDM	10/BAG
100125PL	1" PLUG X FEMALE COUPLER	300	N/A	10/BAG

## 1 1/4" SERIES POLY CAM LEVER COUPLINGS

PART NO	DESCRIPTION	MAX PSI	GASKET	LOT QTY
125A	1" MALE ADAPTER X 1 1/4" FEMALE THREAD	300	N/A	10/BAG
125B	1" FEMALE COUPLER X 1 1/4" MALE THREAD	300	EPDM	10/BAG
125C	1" FEMALE COUPLER X 1 1/4" HOSE BARB	300	EPDM	10/BAG
125D	1" FEMALE COUPLER X 1 1/4" FEMALE THREAD	300	EPDM	10/BAG
125E	1" MALE ADAPTER X 1 1/4" HOSE BARB	300	N/A	10/BAG
125F	1" MALE ADAPTER X 1 1/4" MALE THREAD	300	N/A	10/BAG
100125CAP	1" CAP X MALE ADAPTER	300	EPDM	10/BAG
100125PL	1" PLUG X FEMALE COUPLER	300	N/A	10/BAG

## 1 1/2" X 1 1/4" SERIES POLY CAM LEVER COUPLINGS

PART NO	DESCRIPTION	MAX PSI	GASKET	LOT QTY
150125A	1 1/2" MALE ADAPTER X 1 1/4" FEMALE THREAD	225	N/A	10/BAG
150125B	1 1/2" FEMALE COUPLER X 1 1/4" MALE THREAD	300	EPDM	10
150125C	1 1/2" FEMALE COUPLER X 1 1/4" HOSE BARB	300	EPDM	10
150125D	1 1/2" FEMALE COUPLER X 1 1/4" FEMALE THREAD	300	EPDM	10
150125E	1 1/2" MALE ADAPTER X 1 1/4" HOSE BARB	225	EPDM	10/BAG
150125F	1 1/2" MALE ADAPTER X 1 1/4" MALE THREAD	300	N/A	10/BAG
150CAP	1 1/2" CAP X MALE ADAPTER	300	EPDM	10
150PL	1 1/2" PLUG X FEMALE COUPLER	225	N/A	10/BAG

## 1 1/2" SERIES POLY CAM LEVER COUPLINGS

PART NO	DESCRIPTION	MAX PSI	GASKET	LOT QTY
150A	1 1/2" MALE ADAPTER X 1 1/2" FEMALE THREAD	225	N/A	10/BAG
150B	1 1/2" FEMALE COUPLER X 1 1/2" MALE THREAD	300	EPDM	10
150C	1 1/2" FEMALE COUPLER X 1 1/2" HOSE BARB	300	EPDM	10
150D	1 1/2" FEMALE COUPLER X 1 1/2" FEMALE THREAD	300	EPDM	10
150E	1 1/2" MALE ADAPTER X 1 1/2" HOSE BARB	200	N/A	10/BAG
150F	1 1/2" MALE ADAPTER X 1 1/2" MALE THREAD	300	N/A	10/BAG
150CAP	1 1/2" CAP X MALE ADAPTER	300	EPDM	10
150PL	1 1/2" PLUG X FEMALE COUPLER	225	N/A	10/BAG

## 1/4"-4" POLYPROPYLENE

### FEATURES

- Stainless steel rings, arms and pins
- Versatile — interchangeable with all types of cam lever couplings
- Precision molded — ensures a uniform and accurate fit
- Durable — polypropylene is glass reinforced for rugged strength
- Smooth operating — finger rings are designed for easy opening of cam levers
- Economical and superior in performance
- Standard with EPDM gaskets, FKM gaskets can be ordered separately on page 79
- Where noted, parts must be ordered in bag quantities
- 1/4", 3/8" and 1/2" series couplings interchange with 3/4" size couplings. Coupling ends are 3/4" size.
- 1 1/4" series couplings interchange with 1" size couplings. Coupling ends are 1" size.
- 1 1/2" x 1 1/4" couplings interchange with 1 1/2" size couplings. Coupling ends are 1 1/2" size.



**WARNING!** Couplings should not be disconnected under pressure or with liquid in the line.

# CAM LEVER COUPLINGS

## 1/4"-4" POLYPROPYLENE

### FEATURES

- Stainless steel rings, arms and pins
- Versatile — interchangeable with all types of cam lever couplings
- Precision molded — ensures a uniform and accurate fit
- Durable — polypropylene is glass reinforced for rugged strength
- Smooth operating — finger rings are designed for easy opening of cam levers
- Economical and superior in performance
- Where noted, parts must be ordered in bag quantities
- 1/4", 3/8" and 1/2" series couplings interchange with 3/4" size couplings. Coupling ends are 3/4" size.
- 1 1/4" series couplings interchange with 1" size couplings. Coupling ends are 1" size.
- 1 1/2" x 1 1/4" couplings interchange with 1 1/2" size couplings. Coupling ends are 1 1/2" size.



**WARNING!** Couplings should not be disconnected under pressure or with liquid in the line.

### 2" SERIES POLY CAM LEVER COUPLINGS

PART NO	DESCRIPTION	MAX PSI	GASKET	LOT QTY
200A	2" MALE ADAPTER X 2" FEMALE THREAD	225	N/A	10/BAG
200B	2" FEMALE COUPLER X 2" MALE THREAD	225	EPDM	20
201B	2" FEMALE COUPLER X 2" EXTENDED MALE THREAD	200	EPDM	10
200C	2" FEMALE COUPLER X 2" HOSE BARB	225	EPDM	20
200D	2" FEMALE COUPLER X 2" FEMALE THREAD	200	EPDM	20
200E	2" MALE ADAPTER X 2" HOSE BARB	200	N/A	10/BAG
200F	2" MALE ADAPTER X 2" MALE THREAD	300	N/A	10/BAG
200CAP	2" CAP X MALE ADAPTER	200	EPDM	20
200CAPSH	2" CAP X MALE ADAPTER W/SHORT ARMS	200	EPDM	10
200PL	2" PLUG X FEMALE COUPLER	225	N/A	10/BAG

### 2" X 1 1/2" SERIES POLY CAM LEVER COUPLINGS

PART NO	DESCRIPTION	MAX PSI	GASKET	LOT QTY
200150C	2" FEMALE COUPLER X 1 1/2" HOSE BARB	300	EPDM	10

### 2 1/2" SERIES POLY CAM LEVER COUPLINGS

PART NO	DESCRIPTION	MAX PSI	GASKET	QTY
250CAP	2 1/2" CAP X MALE ADAPTER	300	EPDM	1

### 3" SERIES POLY CAM LEVER COUPLINGS

PART NO	DESCRIPTION	MAX PSI	GASKET	LOT QTY
300A	3" MALE ADAPTER X 3" FEMALE THREAD	100	N/A	10
300B	3" FEMALE COUPLER X 3" MALE THREAD	150	EPDM	10
303B	3" FEMALE COUPLER X 3" EXTENDED MALE THREAD	200	EPDM	10
303B200A	3" FEMALE COUPLER W/ 3 ARMS X 2" MALE ADAPTER	200	EPDM	10
300C	3" FEMALE COUPLER X 3" HOSE BARB	200	EPDM	10
303C	3" FEMALE COUPLER W/ 3 ARMS X 3" HOSE BARB	200	EPDM	10
300D	3" FEMALE COUPLER X 3" FEMALE THREAD	200	EPDM	10
300E	3" MALE ADAPTER X 3" HOSE BARB	150	N/A	10
300F	3" MALE ADAPTER X 3" MALE THREAD	100	N/A	10
300CAP	3" CAP X MALE ADAPTER	100	EPDM	10
300PL	3" PLUG X FEMALE COUPLER	150	N/A	10

### 4" SERIES POLY CAM LEVER COUPLINGS

PART NO	DESCRIPTION	MAX PSI	GASKET	LOT QTY
400A	4" MALE ADAPTER X 4" FEMALE THREAD	75	N/A	10
400B	4" FEMALE COUPLER X 4" MALE THREAD	150	EPDM	10
400C	4" FEMALE COUPLER X 4" HOSE BARB	150	EPDM	10
400D	4" FEMALE COUPLER X 4" FEMALE THREAD	100	EPDM	10
400E	4" MALE ADAPTER X 4" HOSE BARB	50	N/A	10
400F	4" MALE ADAPTER X 4" MALE THREAD	75	N/A	10
400CAP	4" CAP X MALE ADAPTER (W/2 ARMS)	100	EPDM	10
400PL	4" PLUG X FEMALE COUPLER	75	N/A	10



# CAM LEVER COUPLINGS

EASY ACTION  
LOCKING LEVER!



EPDM



FKM

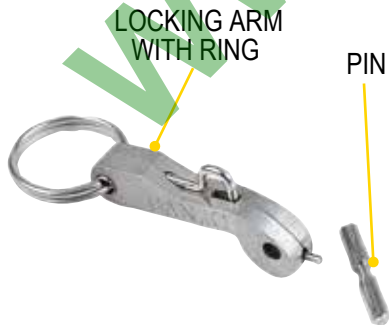

LOCKING ARM  
WITH RING

PIN

## 1½" - 2" SERIES LOCKING POLY CAM LEVER COUPLINGS

PART NO	DESCRIPTION	MAX PSI	GASKET	QTY
L200B	2" FEMALE COUPLER X 2" MALE THREAD	225	EPDM	1
L200C	2" FEMALE COUPLER X 2" HOSE BARB	225	EPDM	1
L200D	2" FEMALE COUPLER X 2" FEMALE THREAD	200	EPDM	1
L200CAP	2" CAP X MALE ADAPTER	200	EPDM	1

## SPOOL ADAPTERS

PART NO	DESCRIPTION	MAX PSI	GASKET	LOT QTY
200FF	2" MALE ADAPTER X 2" MALE ADAPTER	150	N/A	10/BAG
300F200F	3" MALE ADAPTER X 2" MALE ADAPTER	75	N/A	10
300FF	3" MALE ADAPTER X 3" MALE ADAPTER	75	N/A	10

## REPLACEMENT PARTS

PART NO	DESCRIPTION	LOT QTY
100RING	RING FITS ¾" & 1"	1
150RING	RING FITS 1½", 2", 3", 4"	1
150(200)K	1½", 2" SS CAM ARM W/RING	1
300K	3" SS CAM ARM WITH RING	1
V20207	11" LANYARD	1
75G	½" & ¾" EPDM GASKET	25
100G	1" & 1¼" EPDM GASKET	25
100GV	1" & 1¼" FKM GASKET	25
150G	1½" EPDM GASKET	25
150GV	1½" FKM GASKET	25
200G	2" EPDM GASKET	25
200GV	2" FKM GASKET	25
300G	3" EPDM GASKET	25
300GV	3" FKM GASKET	25
400G	4" EPDM GASKET	1
200KL	2" LOCKING CAM ARM WITH RING FITS 1½" & 2"	1
200PKL	2" COUPLING PIN FITS 1½" & 2"	1
200P	2" COUPLING PIN	1
300P	3" COUPLING PIN	1

¼"-4" POLYPROPYLENE

## FEATURES

- Chemical resistant to protect against corrosion
- Versatile to interchange with all types of cam lever couplings
- Smooth operation makes connections quick and easy
- Where noted, parts must be ordered in bag quantities
- Locking cam arm lever is not intended to be used as a security device or prevent unauthorized opening of coupling assembly.



**WARNING!** Couplings should not be disconnected under pressure or with liquid in the line.

# CAM LEVER COUPLINGS

1½"-2" 90° & 45°  
POLYPROPYLENE

## FEATURES

- Precision molded in polypropylene, reinforced with fiberglass for strength
- Stainless steel rings, arms and pins resist corrosion
- 90° angle couplings and adapters will reduce the number of elbows and other pipe fittings used in plumbing applications



**WARNING!** Couplings should not be disconnected under pressure or with liquid in the line.



### 1½" 90° POLY CAM LEVER COUPLINGS

PART NO	DESCRIPTION	MAX PSI	GASKET	LOT QTY
150A90	1½" 90° MALE ADAPTER X 1½" FEMALE THREAD	225	N/A	10/BAG
150C90	1½" 90° FEMALE COUPLER X 1½" HOSE BARB	225	EPDM	10
150D90	1½" 90° FEMALE COUPLER X 1½" FEMALE THREAD	300	EPDM	10
150F90	1½" 90° MALE ADAPTER X 1½" MALE THREAD	300	N/A	10/BAG

### 2" 90° SERIES POLY CAM LEVER COUPLINGS

PART NO	DESCRIPTION	MAX PSI	GASKET	LOT QTY
200A90	2" 90° MALE ADAPTER X 2" FEMALE THREAD	225	N/A	10/BAG
200B90	2" 90° FEMALE COUPLER X 2" MALE THREAD	225	EPDM	10
200C90	2" 90° FEMALE COUPLER X 2" HOSE BARB	225	EPDM	10
200D90	2" 90° FEMALE COUPLER X 2" FEMALE THREAD	200	EPDM	10
200F90	2" 90° MALE ADAPTER X 2" MALE THREAD	225	N/A	10/BAG

### 2" 45° POLY CAM LEVER COUPLINGS

PART NO	DESCRIPTION	MAX PSI	GASKET	LOT QTY
200F45	2" 45° MALE ADAPTER X 2" MALE THREAD	225	N/A	10/BAG

WWW.RONKORP.COM

# CAM LEVER COUPLINGS

## GARDEN HOSE FITTINGS

### FEATURES

- Same construction and design that farmers use for their heavy spraying applications.
- Rugged, secure quick-connect cam arms
- Heavy-duty thick wall reinforced polypropylene
- Proven, leak-free construction
- Full flow design



GARDEN HOSE FITTINGS				
PART NO	DESCRIPTION	MAX PSI	LOT	QTY
GHFT075A	3/4" ADAPTER X 3/4" GARDEN HOSE FEMALE THREAD	225	10/BAG	
GHMT075B	3/4" COUPLER X 3/4" GARDEN HOSE MALE THREAD	300	10/BAG	
GHFT075D	3/4" COUPLER X 3/4" GARDEN HOSE FEMALE THREAD	300	10/BAG	
GHMT075F	3/4" ADAPTER X 3/4" GARDEN HOSE MALE THREAD	300	10/BAG	
GHFT075MPT	3/4" MALE NPT X 3/4" GARDEN HOSE FEMALE THREAD	300	10/BAG	
GHMT075FPT	3/4" FEMALE NPT X 3/4" GARDEN HOSE MALE THREAD	300	10/BAG	
GHMT075MPT	3/4" MALE NPT X 3/4" GARDEN HOSE MALE THREAD	300	10/BAG	
GHFT075G	3/4" GARDEN HOSE FITTING GASKET	N/A	25	



## GARDEN HOSE NOZZLE

### FEATURES

- Heavy duty machined aluminum construction stands up to hard use
- Comfort grip soft rubber
- Resists dents, mars and scratches; protects any surface that comes in contact with nozzle
- Aluminum hose connection provides a tight fit, will not rust
- Multiple spray pattern adjusts from a powerful jet stream to a gentle fan spray. Ideal for all your spraying needs.
- Stainless steel spray cap for precise spray patterns

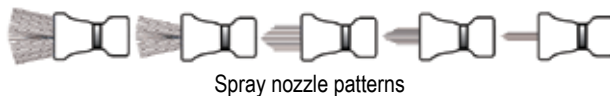

GARDEN HOSE NOZZLE				
PART NO	DESCRIPTION	MAX PSI	QTY	
GHN075	3/4" GARDEN HOSE SPRAY NOZZLE	N/A	1	

# PIPE FITTINGS

## SUPER CLAMPS

### FEATURES

- Stainless steel construction
- 304 stainless steel bolt with 316 stainless steel nut to prevent seizing
- 360° sealing surface
- Ideal for high torque applications
- Strong, positive connections where ordinary hose clamps fail
- T-bolt design
- 3 spot welds for extra strength
- Sold in bags of 10 only
- Torque specifications: working torque 50-80 inch pounds, maximum torque 125 inch pounds
- Please note new Min-Max Diameter measurements.



### SUPER CLAMPS

PART NO	DESCRIPTION	MIN-MAX DIAMETER	MAX TORQUE	LOT QTY
TC120	1" T-BOLT HOSE CLAMP	1.18"-1.34"	75 IN-LBS	10/BAG
TC130	1¼" T-BOLT HOSE CLAMP	1.34"-1.50"	75 IN-LBS	10/BAG
TC150	1½" T-BOLT HOSE CLAMP	1.50"-1.62"	75 IN-LBS	10/BAG
TC162	1¾" T-BOLT HOSE CLAMP	1.62"-1.87"	75 IN-LBS	10/BAG
TC181	1½" T-BOLT HOSE CLAMP	1.84"-2.12"	75 IN-LBS	10/BAG
TC193	1½" T-BOLT HOSE CLAMP	1.93"-2.24"	75 IN-LBS	10/BAG
TC206	2" T-BOLT HOSE CLAMP	2.17"-2.48"	75 IN-LBS	10/BAG
TC218	2" T-BOLT HOSE CLAMP	2.18"-2.52"	75 IN-LBS	10/BAG
TC224	2" T-BOLT HOSE CLAMP	2.24"-2.58"	75 IN-LBS	10/BAG
TC231	2" T-BOLT HOSE CLAMP	2.31"-2.65"	75 IN-LBS	10/BAG
TC250	2" T-BOLT HOSE CLAMP	2.50"-2.81"	75 IN-LBS	10/BAG
TC287	2" T-BOLT HOSE CLAMP	2.83"-3.21"	75 IN-LBS	10/BAG
TC312	3" T-BOLT HOSE CLAMP	3.24"-3.58"	75 IN-LBS	10/BAG
TC331	3" T-BOLT HOSE CLAMP	3.27"-3.65"	75 IN-LBS	10/BAG
TC343	3" T-BOLT HOSE CLAMP	3.39"-3.77"	75 IN-LBS	10/BAG
TC425	4" T-BOLT HOSE CLAMP	4.21"-4.59"	75 IN-LBS	10/BAG
TC438	4" T-BOLT HOSE CLAMP	4.28"-4.69"	125 IN-LBS	10/BAG
TC456	4" T-BOLT HOSE CLAMP	4.46"-4.87"	125 IN-LBS	10/BAG

WWW.ROLERONIK.PL



## NIPPLES

PART NO	DESCRIPTION	MAX PSI	LOT QTY
NIP025-SH	1/4" SHORT POLY NIPPLE	300	10/BAG
NIP038-SH	3/8" SHORT POLY NIPPLE	300	10/BAG
NIP050-SH	1/2" SHORT POLY NIPPLE	300	10/BAG
NIP050-3	1/2" X 3" POLY NIPPLE	300	10/BAG
NIP075-SH	3/4" SHORT POLY NIPPLE	300	10/BAG
NIP075-4	3/4" X 4" POLY NIPPLE	300	10/BAG
NIP075-6	3/4" X 6" POLY NIPPLE	300	10/BAG
NIP100-SH	1" SHORT POLY NIPPLE	300	10/BAG
NIP100-4	1" X 4" POLY NIPPLE	300	10/BAG
NIP100-6	1" X 6" POLY NIPPLE	300	10/BAG
NIP125-SH	1 1/4" SHORT POLY NIPPLE	300	10/BAG
NIP125-4	1 1/4" X 4" POLY NIPPLE	300	10/BAG
NIP125-6	1 1/4" X 6" POLY NIPPLE	300	10/BAG
NIP150-SH	1 1/2" SHORT POLY NIPPLE	300	10/BAG
NIP150-3	1 1/2" X 3" POLY NIPPLE	300	10/BAG
NIP150-4	1 1/2" X 4" POLY NIPPLE	300	10/BAG
NIP150-5	1 1/2" X 5" POLY NIPPLE	300	10/BAG
NIP150-6	1 1/2" X 6" POLY NIPPLE	300	10/BAG
NIP200-SH	2" SHORT POLY NIPPLE	300	10/BAG
NIP200-4	2" X 4" POLY NIPPLE	300	10/BAG
NIP200-6	2" X 6" POLY NIPPLE	300	10/BAG
NIP300-SH	3" SHORT POLY NIPPLE	300	10/BAG
NIP300-4	3" X 4" POLY NIPPLE	300	10/BAG
NIP300-6	3" X 6" POLY NIPPLE	300	10



## REDUCING NIPPLES

PART NO	DESCRIPTION	MAX PSI	LOT QTY
RN050-038	1/2" X 3/8" POLY REDUCING NIPPLE	300	10/BAG
RN075-050	3/4" X 1/2" POLY REDUCING NIPPLE	300	10/BAG
RN100-050	1" X 1/2" POLY REDUCING NIPPLE	300	10/BAG
RN100-075	1" X 3/4" POLY REDUCING NIPPLE	300	10/BAG
RN125-075	1 1/4" X 3/4" POLY REDUCING NIPPLE	300	10/BAG
RN125-100	1 1/4" X 1" POLY REDUCING NIPPLE	300	10/BAG
RN150-100	1 1/2" X 1" POLY REDUCING NIPPLE	300	10/BAG
RN150-125	1 1/2" X 1 1/4" POLY REDUCING NIPPLE	300	10/BAG
RN200-125	2" X 1 1/4" POLY REDUCING NIPPLE	300	10/BAG
RN200-150	2" X 1 1/2" POLY REDUCING NIPPLE	300	10/BAG
RN300-200	3" X 2" POLY REDUCING NIPPLE	300	10/BAG



## PIPE COUPLINGS

PART NO	DESCRIPTION	MAX PSI	LOT QTY
CPLG025	1/4" POLY PIPE COUPLING	300	10/BAG
CPLG038	3/8" POLY PIPE COUPLING	300	10/BAG
CPLG050	1/2" POLY PIPE COUPLING	300	10/BAG
CPLG075	3/4" POLY PIPE COUPLING	300	10/BAG
CPLG100	1" POLY PIPE COUPLING	300	10/BAG
CPLG125	1 1/4" POLY PIPE COUPLING	300	10/BAG
CPLG150	1 1/2" POLY PIPE COUPLING	300	10/BAG
CPLG200	2" POLY PIPE COUPLING	300	10/BAG
CPLG300	3" POLY PIPE COUPLING	225	5



## REDUCING COUPLINGS

PART NO	DESCRIPTION	MAX PSI	LOT QTY
RC100-075	1" X 3/4" POLY REDUCING COUPLING	300	10/BAG
RC150-100	1 1/2" X 1" POLY REDUCING COUPLING	300	10/BAG
RC150-125	1 1/2" X 1 1/4" POLY REDUCING COUPLING	300	10/BAG
RC200-050	2" X 1/2" POLY REDUCING COUPLING	300	10/BAG
RC200-100	2" X 1" POLY REDUCING COUPLING	300	10/BAG
RC200-125	2" X 1 1/4" POLY REDUCING COUPLING	300	10/BAG
RC200-150	2" X 1 1/2" POLY REDUCING COUPLING	300	10/BAG
RC300-200	3" X 2" POLY REDUCING COUPLING	300	5



## REDUCING BUSHINGS

PART NO	DESCRIPTION	MAX PSI	LOT QTY
RB038-025	3/8" MPT X 1/4" FPT REDUCING BUSHING	300	10/BAG
RB050-025	1/2" MPT X 1/4" FPT REDUCING BUSHING	300	10/BAG
RB050-038	1/2" MPT X 3/8" FPT REDUCING BUSHING	300	10/BAG
RB075-025	3/4" MPT X 1/4" FPT REDUCING BUSHING	300	10/BAG
RB075-038	3/4" MPT X 3/8" FPT REDUCING BUSHING	300	10/BAG
RB075-050	3/4" MPT X 1/2" FPT REDUCING BUSHING	300	10/BAG
RB100-025	1" MPT X 1/4" FPT REDUCING BUSHING	300	10/BAG
RB100-050	1" MPT X 1/2" FPT REDUCING BUSHING	300	10/BAG
RB100-075	1" MPT X 3/4" FPT REDUCING BUSHING	300	10/BAG
RB125-075	1 1/4" MPT X 3/4" FPT REDUCING BUSHING	300	10/BAG
RB125-100	1 1/4" MPT X 1" FPT REDUCING BUSHING	300	10/BAG
RB150-075	1 1/2" MPT X 3/4" FPT REDUCING BUSHING	300	10/BAG
RB150-100	1 1/2" MPT X 1" FPT REDUCING BUSHING	300	10/BAG
RB150-125	1 1/2" MPT X 1 1/4" FPT REDUCING BUSHING	300	10/BAG
RB200-075	2" MPT X 3/4" FPT REDUCING BUSHING	300	10/BAG
RB200-100	2" MPT X 1" FPT REDUCING BUSHING	300	10/BAG
RB200-125	2" MPT X 1 1/4" FPT REDUCING BUSHING	300	10/BAG
RB200-150	2" MPT X 1 1/2" FPT REDUCING BUSHING	300	10/BAG
RB300-150	3" MPT X 1 1/2" FPT REDUCING BUSHING	300	10
RB300-200	3" MPT X 2" FPT REDUCING BUSHING	300	10/BAG
RB400-300	4" MPT X 3" FPT REDUCING BUSHING	300	5

## PIPE FITTINGS

### FEATURES

- Glass reinforced polypropylene
- Heavy duty (Schedule 80)
- Lightweight with excellent strength
- NPT threads
- Excellent chemical resistance
- Where noted, parts must be ordered in bag quantities

# PIPE FITTINGS

## PIPE FITTINGS

### FEATURES

- Glass reinforced polypropylene
- Heavy duty (Schedule 80)
- Lightweight with excellent strength
- NPT threads
- Excellent chemical resistance
- Where noted, parts must be ordered in bag quantities



PIPE CAPS			
PART NO	DESCRIPTION	MAX PSI	LOT QTY
CAP038	3/8" POLY PIPE CAP	300	10/BAG
CAP050	1/2" POLY PIPE CAP	300	10/BAG
CAP075	3/4" POLY PIPE CAP	300	10/BAG
CAP100	1" POLY PIPE CAP	300	10/BAG
CAP125	1 1/4" POLY PIPE CAP	300	10/BAG
CAP150	1 1/2" POLY PIPE CAP	300	10/BAG
CAP200	2" POLY PIPE CAP	300	10/BAG
CAP300	3" POLY PIPE CAP	300	5



CROSSES			
PART NO	DESCRIPTION	MAX PSI	LOT QTY
CR050	1/2" POLY CROSS	300	10/BAG
CR075	3/4" POLY CROSS	300	10/BAG
CR100	1" POLY CROSS	300	10/BAG
CR125	1 1/4" POLY CROSS	300	10/BAG
CR150	1 1/2" POLY CROSS	300	10
CR200	2" POLY CROSS	300	10



PIPE PLUGS			
PART NO	DESCRIPTION	MAX PSI	LOT QTY
PLUG025	1/4" POLY PIPE PLUG	300	10/BAG
PLUG038	3/8" POLY PIPE PLUG	300	10/BAG
PLUG050	1/2" POLY PIPE PLUG	300	10/BAG
PLUG075	3/4" POLY PIPE PLUG	300	10/BAG
PLUG100	1" POLY PIPE PLUG	300	10/BAG
PLUG125	1 1/4" POLY PIPE PLUG	300	10/BAG
PLUG150	1 1/2" POLY PIPE PLUG	300	10/BAG
PLUG200	2" POLY PIPE PLUG	300	10/BAG
PLUG300	3" POLY PIPE PLUG	300	10



TEES			
PART NO	DESCRIPTION	MAX PSI	LOT QTY
TEE025	1/4" POLY TEE	300	10/BAG
TEE038	3/8" POLY TEE	300	10/BAG
TEE050	1/2" POLY TEE	300	10/BAG
TEE075	3/4" POLY TEE	300	10/BAG
TEE100	1" POLY TEE	300	10/BAG
TEE125	1 1/4" POLY TEE	300	10/BAG
TEE150	1 1/2" POLY TEE	300	10/BAG
TEE200	2" POLY TEE	300	10/BAG
TEE300	3" POLY TEE	225	10



HOSE BARB CROSS			
PART NO	DESCRIPTION	MAX PSI	LOT QTY
HBC050075	1/2" X 3/4" HOSE BARB CROSS	300	10/BAG



GAUGE PORT TEE			
PART NO	DESCRIPTION	MAX PSI	LOT QTY
TEG075	3/4" POLY TEE W/ 1/4" FEMALE THREAD	300	10/BAG
TEG100	1" POLY TEE W/ 1/4" FEMALE THREAD	300	10/BAG

WWW.BANJO.COM

## PIPE FITTINGS



### 90° ELBOWS

PART NO	DESCRIPTION	MAX PSI	LOT QTY
EL025-90	¼" 90° POLY ELBOW	300	10/BAG
EL038-90	⅜" 90° POLY ELBOW	300	10/BAG
EL050-90	½" 90° POLY ELBOW	300	10/BAG
EL075-90	¾" 90° POLY ELBOW	300	10/BAG
EL100-90	1" 90° POLY ELBOW	300	10/BAG
EL125-90	1¼" 90° POLY ELBOW	300	10/BAG
EL150-90	1½" 90° POLY ELBOW	300	10/BAG
EL200-90	2" 90° POLY ELBOW	300	10/BAG
EL300-90	3" 90° POLY ELBOW	300	10



### 45° STREET ELBOWS

PART NO	DESCRIPTION	MAX PSI	LOT QTY
SL075-45	¾" 45° POLY STREET ELBOW	300	10/BAG
SL100-45	1" 45° POLY STREET ELBOW	300	10/BAG
SL125-45	1¼" 45° POLY STREET ELBOW	300	10/BAG
SL150-45	1½" 45° POLY STREET ELBOW	300	10/BAG
SL200-45	2" 45° POLY STREET ELBOW	225	10/BAG
SL300-45	3" 45° POLY STREET ELBOW	300	5

### FEATURES

- Glass reinforced polypropylene
- Heavy duty (Schedule 80)
- Lightweight with excellent strength
- NPT threads
- Excellent chemical resistance
- Where noted, parts must be ordered in bag quantities



### 45° ELBOW

PART NO	DESCRIPTION	MAX PSI	LOT QTY
EL100-45	1" 45° POLY ELBOW	300	10/BAG



### 90° HOSE BARB ELBOW

PART NO	DESCRIPTION	MAX PSI	LOT QTY
HBB20012590	2" X 1¼" 90° POLY HOSE BARB ELBOW	300	10/BAG



### 90° STREET ELBOWS

PART NO	DESCRIPTION	MAX PSI	LOT QTY
SL025-90	¼" 90° POLY STREET ELBOW	300	10/BAG
SL038-90	⅜" 90° POLY STREET ELBOW	300	10/BAG
SL050-90	½" 90° POLY STREET ELBOW	300	10/BAG
SL075-90	¾" 90° POLY STREET ELBOW	300	10/BAG
SL100-90	1" 90° POLY STREET ELBOW	300	10/BAG
SL125-90	1¼" 90° POLY STREET ELBOW	300	10/BAG
SL150-90	1½" 90° POLY STREET ELBOW	300	10/BAG
SL200-90	2" 90° POLY STREET ELBOW	300	10/BAG
SL300-90	3" 90° POLY STREET ELBOW	300	10



### 90° HOSE BARB ELBOW

PART NO	DESCRIPTION	MAX PSI	LOT QTY
HBEL100-90	1" 90° POLY HOSE BARB ELBOW	300	10/BAG
HBEL150/100-90	1½" X 1" 90° POLY HOSE BARB ELBOW	300	10/BAG

# PIPE FITTINGS

## HOSE BARBS



### FEATURES

- Glass reinforced polypropylene
- Heavy duty (Schedule 80)
- Lightweight with excellent strength
- NPT threads
- Excellent chemical resistance
- Where noted, parts must be ordered in bag quantities

### STRAIGHT HOSE BARBS

PART NO	DESCRIPTION	MAX PSI	LOT QTY
HB025	1/4" MALE THREAD X 1/4" HOSE BARB	300	10/BAG
HB025-038	1/4" MALE THREAD X 3/8" HOSE BARB	300	10/BAG
HB025-050	1/4" MALE THREAD X 1/2" HOSE BARB	300	10/BAG
HB038	3/8" MALE THREAD X 3/8" HOSE BARB	300	10/BAG
HB038-050	3/8" MALE THREAD X 1/2" HOSE BARB	300	10/BAG
HB050-025	1/2" MALE THREAD X 1/4" HOSE BARB	300	10/BAG
HB050-038	1/2" MALE THREAD X 3/8" HOSE BARB	300	10/BAG
HB050	1/2" MALE THREAD X 1/2" HOSE BARB	300	10/BAG
HB050-075	1/2" MALE THREAD X 3/4" HOSE BARB	300	10/BAG
HB075-038	3/4" MALE THREAD X 3/8" HOSE BARB	300	10/BAG
HB075-050	3/4" MALE THREAD X 1/2" HOSE BARB	300	10/BAG
HB075-058	3/4" MALE THREAD X 5/8" HOSE BARB	300	10/BAG
HB075	3/4" MALE THREAD X 3/4" HOSE BARB	300	10/BAG
HB075-100	3/4" MALE THREAD X 1" HOSE BARB	300	10/BAG
HB100-075	1" MALE THREAD X 3/4" HOSE BARB	300	10/BAG
HB100	1" MALE THREAD X 1" HOSE BARB	300	10/BAG
HB100-125	1" MALE THREAD X 1 1/4" HOSE BARB	300	10/BAG
HB125-075	1 1/4" MALE THREAD X 3/4" HOSE BARB	300	10/BAG
HB125-100	1 1/4" MALE THREAD X 1" HOSE BARB	300	10/BAG
HB125	1 1/4" MALE THREAD X 1 1/4" HOSE BARB	300	10/BAG
HB125-150	1 1/4" MALE THREAD X 1 1/2" HOSE BARB	300	10/BAG
HB150-100	1 1/2" MALE THREAD X 1" HOSE BARB	300	10/BAG
HB150-125	1 1/2" MALE THREAD X 1 1/4" HOSE BARB	300	10/BAG
HB150	1 1/2" MALE THREAD X 1 1/2" HOSE BARB	300	10/BAG
HB150-200	1 1/2" MALE THREAD X 2" HOSE BARB	300	10/BAG
HB200-150	2" MALE THREAD X 1 1/2" HOSE BARB	300	10/BAG
HB200	2" MALE THREAD X 2" HOSE BARB	300	10/BAG
HB300	3" MALE THREAD X 3" HOSE BARB	225	10
HB400	4" MALE THREAD X 4" HOSE BARB	150	1

### 90° HOSE BARBS

PART NO	DESCRIPTION	MAX PSI	LOT QTY
HB025-90	1/4" MALE THREAD X 1/4" 90° HOSE BARB	300	10/BAG
HB025/038-90	1/4" MALE THREAD X 3/8" 90° HOSE BARB	300	10/BAG
HB025/050-90	1/4" MALE THREAD X 1/2" 90° HOSE BARB	300	10/BAG
HB038-90	3/8" MALE THREAD X 3/8" 90° HOSE BARB	300	10/BAG
HB050/038-90	1/2" MALE THREAD X 3/8" 90° HOSE BARB	300	10/BAG
HB050-90	1/2" MALE THREAD X 1/2" 90° HOSE BARB	300	10/BAG
HB050/075-90	1/2" MALE THREAD X 3/4" 90° HOSE BARB	300	10/BAG
HB075/050-90	3/4" MALE THREAD X 1/2" 90° HOSE BARB	300	10/BAG
HB075-90	3/4" MALE THREAD X 3/4" 90° HOSE BARB	300	10/BAG
HB075/100-90	3/4" MALE THREAD X 1" 90° HOSE BARB	300	10/BAG
HB100/075-90	1" MALE THREAD X 3/4" 90° HOSE BARB	300	10/BAG
HB100-90	1" MALE THREAD X 1" 90° HOSE BARB	300	10/BAG
HB100/125-90	1" MALE THREAD X 1 1/4" 90° HOSE BARB	300	10/BAG
HB125/100-90	1 1/4" MALE THREAD X 1" 90° HOSE BARB	300	10/BAG
HB125-90	1 1/4" MALE THREAD X 1 1/4" 90° HOSE BARB	300	10/BAG
HB125/150-90	1 1/4" MALE THREAD X 1 1/2" 90° HOSE BARB	300	10/BAG
HB150/125-90	1 1/2" MALE THREAD X 1 1/4" 90° HOSE BARB	300	10/BAG
HB150-90	1 1/2" MALE THREAD X 1 1/2" 90° HOSE BARB	300	10/BAG
HB200/150-90	2" MALE THREAD X 1 1/2" 90° HOSE BARB	300	10/BAG
HB200-90	2" MALE THREAD X 2" 90° HOSE BARB	300	10/BAG
HB300-90	3" MALE THREAD X 3" 90° HOSE BARB	225	10



### 316 STAINLESS STEEL HOSE BARBS

PART NO	DESCRIPTION	MAX PSI	LOT QTY
HB025SS	1/4" MALE THREAD X 1/4" HOSE BARB	300	10
HB025-038SS	1/4" MALE THREAD X 3/8" HOSE BARB	300	10
HB025-050SS	1/4" MALE THREAD X 1/2" HOSE BARB	300	10
HB038SS	3/8" MALE THREAD X 3/8" HOSE BARB	300	10
HB038-050SS	3/8" MALE THREAD X 1/2" HOSE BARB	300	10
HB050SS	1/2" MALE THREAD X 1/2" HOSE BARB	300	10
HB050-058SS	1/2" MALE THREAD X 5/8" HOSE BARB	300	1
HB050-075SS	1/2" MALE THREAD X 3/4" HOSE BARB	300	10
HB075-050SS	3/4" MALE THREAD X 1/2" HOSE BARB	300	10
HB075SS	3/4" MALE THREAD X 3/4" HOSE BARB	300	10
HB075-100SS	3/4" MALE THREAD X 1" HOSE BARB	300	1
HB100-075SS	1" MALE THREAD X 3/4" HOSE BARB	300	1
HB100SS	1" MALE THREAD X 1" HOSE BARB	300	10
HB125SS	1 1/4" MALE THREAD X 1 1/4" HOSE BARB	300	1
HB150SS	1 1/2" MALE THREAD X 1 1/2" HOSE BARB	300	10
HB200SS	2" MALE THREAD X 2" HOSE BARB	300	1
HB300SS	3" MALE THREAD X 3" HOSE BARB	300	1

### FEMALE HOSE BARBS

PART NO	DESCRIPTION	MAX PSI	LOT QTY
HBF075	3/4" FEMALE THREAD X 3/4" HOSE BARB	300	10/BAG
HBF075-90	3/4" FEMALE THREAD X 3/4" 90° HOSE BARB	300	10/BAG
HBF075-100	3/4" FEMALE THREAD X 1" HOSE BARB	300	10/BAG
HBF100	1" FEMALE THREAD X 1" HOSE BARB	300	10/BAG







## HOSE BARB TEES

PART NO	DESCRIPTION	MAX PSI	LOT QTY
HBT038	3/8" HOSE BARB TEE	300	10/BAG
HBT050	1/2" HOSE BARB TEE	300	10/BAG
HBT050-075	1/2" X 1/2" X 3/4" HOSE BARB TEE	300	10/BAG
HBT075-050	3/4" X 3/4" X 1/2" HOSE BARB TEE	300	10/BAG
HBT075	3/4" HOSE BARB TEE	300	10/BAG
HBT075-100	3/4" X 3/4" X 1" HOSE BARB TEE	300	10/BAG
HBT100-075	1" X 1" X 3/4" HOSE BARB TEE	300	10/BAG
HBT100	1" HOSE BARB TEE	300	10/BAG
HBT200	2" HOSE BARB TEE	300	10
HBT300	3" HOSE BARB TEE	300	1



## HOSE BARB THREADED TEES

PART NO	DESCRIPTION	MAX PSI	LOT QTY
HBT100-100	1" HOSE BARB X 1" HOSE BARB X 1" MALE THREAD HOSE BARB TEE	300	10/BAG
HBT150-100	1 1/2" HOSE BARB X 1 1/2" HOSE BARB X 1" MALE THREAD HOSE BARB TEE	300	10/BAG
HBT150-150	1 1/2" HOSE BARB X 1 1/2" HOSE BARB X 1 1/2" MALE THREAD HOSE BARB TEE	300	10/BAG



## SS HOSE BARB THREADED TEES

PART NO	DESCRIPTION	MAX PSI	QTY
HBT075-050SS	3/4" HOSE BARB X 3/4" HOSE BARB X 1/2" HOSE BARB TEE	150	1



## HOSE MENDERS

PART NO	DESCRIPTION	MAX PSI	LOT QTY
HM038	3/8" X 3/8" HOSE BARB	300	10/BAG
HM050	1/2" X 1/2" HOSE BARB	300	10/BAG
HM075	3/4" X 3/4" HOSE BARB	300	10/BAG
HM100	1" X 1" HOSE BARB	300	10/BAG
HM125	1 1/4" X 1 1/4" HOSE BARB	300	10/BAG
HM150	1 1/2" X 1 1/2" HOSE BARB	300	10/BAG
HM200	2" X 2" HOSE BARB	300	10/BAG
HM300	3" X 3" HOSE BARB	300	10



## SWIVELS

PART NO	DESCRIPTION	MAX PSI	LOT QTY
SW100	1" MALE X 1" FEMALE SWIVEL	300	10
SW150	1 1/2" MALE X 1 1/2" FEMALE SWIVEL	300	1
SW220	2" FULL PORT MALE X 2" FULL PORT FEMALE SWIVEL	150	1



## 8 STATION MANIFOLD

PART NO	DESCRIPTION	MAX PSI	QTY
TM075/050	8 STATION MANIFOLD 3/4" INLET X 1/2" OUTLET, 1/4" GAUGE PORT	225	1

## PIPE FITTINGS

### FEATURES

- Glass reinforced polypropylene
- Heavy duty (Schedule 80)
- Lightweight with excellent strength
- NPT threads
- Excellent chemical resistance
- Where noted, parts must be ordered in bag quantities

Recommended procedure for sealing pipe threads:

We DO NOT recommend using pipe tape. Pipe tape enlarges the outside diameter of the male thread and may cause the female thread to split. We recommend using a pipe thread sealant. Use on clean tapered threads. Apply a thick even coat on male threads using brush applicator. For pipe diameters smaller than 1 1/4" apply to male threads only. For 1 1/4" and larger sizes apply to both male and female threads. Avoid applying excessive amounts. Hand tighten joints and then torque another 1/2 to 3/4 turn until threads seal.



## PIPE SEALANT

PART NO	DESCRIPTION	LOT QTY
RS21	RECTORSEAL® NO. 21™ (8 OZ W/ BRUSH IN CAP-24/CASE)	1
RSTB	RECTORSEAL® TRU-BLU™ (8 OZ W/ BRUSH IN CAP-24/CASE)	24

## PIPE SEALANT

### FEATURES

- RectorSeal® No. 21™ is slow drying, soft set multi-purpose sealant designed for use where black is preferred. 8 oz can with brush in the cap. Conforms to TT-S-1732.
- RectorSeal® Tru-Blu™ is fast drying, flexible set designed for high vibration environments. Teflon™ has been added to enhance thread lubrication during assembly and break out. Conforms to TT-S-1732.

\*DuPont Registered Trademark

# LINE STRAINERS

## MINI T STRAINERS

### FEATURES

- Heavy duty glass reinforced polypropylene
- Clear bowl made of polycarbonate
- Black bowl made of polypropylene
- Polypropylene ribbed 316 stainless steel screens
- EPDM gaskets
- Convenient color coded screens for easy mesh size identification (Refer to chart on next page)



### MINI T STRAINERS W/CLEAR BOWLS

PART NO	DESCRIPTION	MAX PSI	QTY
LSTM050-30C	1/2" X 1/2" CLEAR BOWL STRAINER W/30 MESH SCREEN	100	1
LSTM050-50C	1/2" X 1/2" CLEAR BOWL STRAINER W/50 MESH SCREEN	100	1
LSTM050-80C	1/2" X 1/2" CLEAR BOWL STRAINER W/80 MESH SCREEN	100	1
LSTM075-30C	3/4" X 3/4" CLEAR BOWL STRAINER W/30 MESH SCREEN	100	1
LSTM075-50C	3/4" X 3/4" CLEAR BOWL STRAINER W/50 MESH SCREEN	100	1
LSTM075-80C	3/4" X 3/4" CLEAR BOWL STRAINER W/80 MESH SCREEN	100	1



### MINI T STRAINERS W/BLACK BOWLS

PART NO	DESCRIPTION	MAX PSI	QTY
LSTM050-30	1/2" X 1/2" BLACK BOWL STRAINER W/30 MESH SCREEN	200	1
LSTM050-50	1/2" X 1/2" BLACK BOWL STRAINER W/50 MESH SCREEN	200	1
LSTM050-80	1/2" X 1/2" BLACK BOWL STRAINER W/80 MESH SCREEN	200	1
LSTM075-30	3/4" X 3/4" BLACK BOWL STRAINER W/30 MESH SCREEN	200	1
LSTM075-50	3/4" X 3/4" BLACK BOWL STRAINER W/50 MESH SCREEN	200	1
LSTM075-80	3/4" X 3/4" BLACK BOWL STRAINER W/80 MESH SCREEN	200	1

WWW.POLTRONLINE.COM

## MINI T STRAINERS

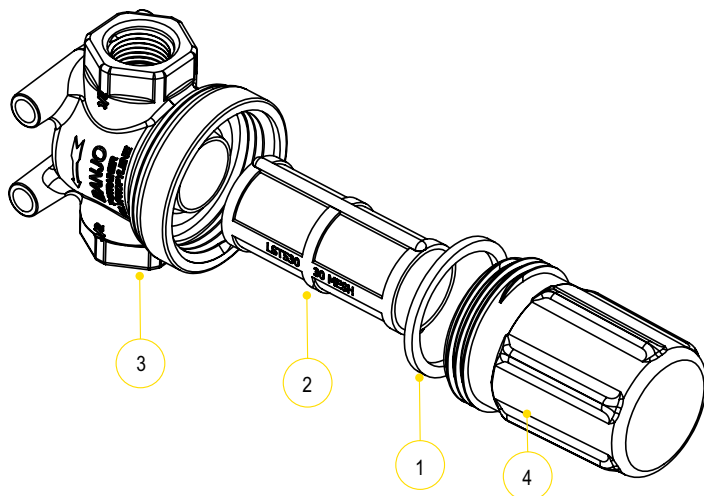

SCREENS	
MESH SIZE	RIB COLOR
30 MESH	FLAME RED
50 MESH	GENTIAN BLUE
80 MESH	ZINC YELLOW
100 MESH	TRAFFIC GREEN

### REPLACEMENT PARTS

ITEM	PART NO	DESCRIPTION	QTY
1	LSTM050G	EPDM GASKET	1
2	LST530	30 MESH SCREEN	1
2	LST550	50 MESH SCREEN	1
2	LST580	80 MESH SCREEN	1
2	LST5100	100 MESH SCREEN	1
3	LSTM050H	1/2" STRAINER HEAD	1
3	LSTM075H	3/4" STRAINER HEAD	1
4	LSTM050BC	CLEAR BOWL	1
4	LSTM050B	BLACK BOWL	1

### STANDARD MESHES & DATA

	30 MESH	50 MESH	80 MESH	100 MESH
MICRONS	595	297	177	149
WIRE DIAMETER	.012	.009	.0055	.0045
OPENING	.021	.011	.007	.005
% OPEN AREA	40.8	30.3	31.4	30.3

# LINE STRAINERS

## ¾"-1½" T STRAINERS

### FEATURES

- Heavy duty glass reinforced polypropylene
- Clean out plug
- Polypropylene ribbed 316 stainless steel screens
- EPDM gaskets standard, FKM available
- Convenient color coded screens for easy mesh size identification (Refer to chart on next page)



### ¾"-1" T STRAINERS

PART NO	DESCRIPTION	MAX PSI	QTY
LST075-16	¾" X ¾" FP T STRAINER W/16 MESH SS SCREEN	300	1
LST075-30	¾" X ¾" FP T STRAINER W/30 MESH SS SCREEN	300	1
LST075-50	¾" X ¾" FP T STRAINER W/50 MESH SS SCREEN	300	1
LST075-80	¾" X ¾" FP T STRAINER W/80 MESH SS SCREEN	300	1
LST075-100	¾" X ¾" FP T STRAINER W/100 MESH SS SCREEN	300	1
LST100-16	1" X 1" T STRAINER W/16 MESH SS SCREEN	300	1
LST100-30	1" X 1" T STRAINER W/30 MESH SS SCREEN	300	1
LST100-50	1" X 1" T STRAINER W/50 MESH SS SCREEN	300	1
LST100-80	1" X 1" T STRAINER W/80 MESH SS SCREEN	300	1
LST100-100	1" X 1" T STRAINER W/100 MESH SS SCREEN	300	1

### 1¼"-1½" T STRAINERS

PART NO	DESCRIPTION	MAX PSI	QTY
LST125-16	1¼" X 1¼" FP T STRAINER W/16 MESH SS SCREEN	300	1
LST125-30	1¼" X 1¼" FP T STRAINER W/30 MESH SS SCREEN	300	1
LST125-50	1¼" X 1¼" FP T STRAINER W/50 MESH SS SCREEN	300	1
LST125-80	1¼" X 1¼" FP T STRAINER W/80 MESH SS SCREEN	300	1
LST150-30	1½" X 1½" T STRAINER W/30 MESH SS SCREEN	300	1
LST150-50	1½" X 1½" T STRAINER W/50 MESH SS SCREEN	300	1
LST150-80	1½" X 1½" T STRAINER W/80 MESH SS SCREEN	300	1
LST150-100	1½" X 1½" T STRAINER W/100 MESH SS SCREEN	300	1

## 3/4" - 1 1/2" T STRAINERS

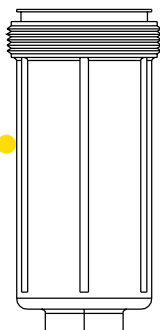
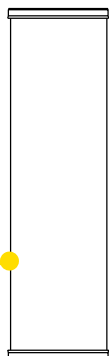
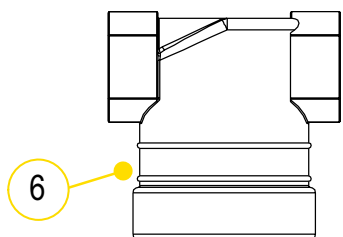

REPLACEMENT PARTS			
ITEM	PART NO	DESCRIPTION	QTY
1	LST100-B	3/4" & 1" BOWL (CONTAINS #1, #3, #4)	1
2	LST100-G	3/4" & 1" EPDM GASKET	1
2	LST100-GV	3/4" & 1" FKM GASKET	1
3	12777	1/2" PLUG	1
4	UV15163	EPDM O-RING FOR CLEAN OUT PLUG	1
5	LST116	16 MESH SCREEN	1
5	LST130	30 MESH SCREEN	1
5	LST150	50 MESH SCREEN	1
5	LST180	80 MESH SCREEN	1
5	LST1100	100 MESH SCREEN	1
6	LST075-H	3/4" STRAINER HEAD	1
6	LST100-H	1" STRAINER HEAD	1
N/S	LST075-HB	3/4" STRAINER HEAD, BOWL & GASKET	1
N/S	LST100-HB	1" STRAINER HEAD, BOWL & GASKET	1

REPLACEMENT PARTS			
ITEM	PART NO	DESCRIPTION	QTY
1	LST150-B	1 1/4" & 1 1/2" BOWL (CONTAINS #1, #3, #4)	1
2	LST150-G	1 1/4" & 1 1/2" EPDM GASKET	1
2	LST150-GV	1 1/4" & 1 1/2" FKM GASKET	1
3	LSQ200-PL	1" CLEAN OUT PLUG	1
4	LSQ200-R	EPDM O-RING FOR CLEAN OUT PLUG	1
5	LST1516	16 MESH SCREEN	1
5	LST1530	30 MESH SCREEN	1
5	LST1550	50 MESH SCREEN	1
5	LST1580	80 MESH SCREEN	1
5	LST15100	100 MESH SCREEN	1
6	LST125-H	1 1/4" STRAINER HEAD	1
N/S	LST125-HB	1 1/4" STRAINER HEAD, BOWL & GASKET	1
N/S	LST150-HB	1 1/2" STRAINER HEAD, BOWL & GASKET	1

SCREENS	
MESH SIZE	RIB COLOR
16 MESH	BROWN RED
30 MESH	FLAME RED
50 MESH	GENTIAN BLUE
80 MESH	ZINC YELLOW
100 MESH	TRAFFIC GREEN

STANDARD MESHERS & DATA					
	16 MESH	30 MESH	50 MESH	80 MESH	100 MESH
MICRONS	1190	595	297	177	149
WIRE DIAMETER	.018	.012	.009	.0055	.0045
OPENING	.044	.021	.011	.007	.005
% OPEN AREA	50.7	40.8	30.3	31.4	30.3

# LINE STRAINERS

## 2" T STRAINERS POLY/STAINLESS COMBO



### FEATURES

- Heavy duty glass reinforced polypropylene bowl
- 316 stainless steel head
- Clean out plug
- 316 stainless steel screens
- FKM gaskets

### 2" T STRAINERS POLY/SS COMBO

PART NO	DESCRIPTION	MAX PSI	QTY
LST200-10SS	2" X 2" T STRAINER (SS HEAD & POLY BODY) W/10 MESH SCREEN	300	1
LST200-50SS	2" X 2" T STRAINER (SS HEAD & POLY BODY) W/50 MESH SCREEN	300	1

## LSQ STRAINERS

### FEATURES

- Precision molded in glass reinforced polypropylene
- Cam lever configuration for easy access for cleaning and servicing
- 3/4" plug in cam lever cap for attaching ball valve for draining or back flushing
- Poly ribbed 316 stainless steel screen
- EPDM lathe cut gasket
- For faster shipping, order in box quantities
- Convenient color coded screens for easy mesh size identification (Refer to chart on next page)



### 2" LSQ STRAINERS

PART NO	DESCRIPTION	MAX PSI	LOT QTY
LSQ200-06	2" X 2" LSQ STRAINER W/6 MESH SCREEN	100	6/BOX
LSQ200-20	2" X 2" LSQ STRAINER W/20 MESH SCREEN	100	6/BOX
LSQ200-30	2" X 2" LSQ STRAINER W/30 MESH SCREEN	100	6/BOX
LSQ200-50	2" X 2" LSQ STRAINER W/50 MESH SCREEN	100	6/BOX
LSQ200-80	2" X 2" LSQ STRAINER W/80 MESH SCREEN	100	6/BOX

## 2" T STRAINERS POLY/STAINLESS COMBO

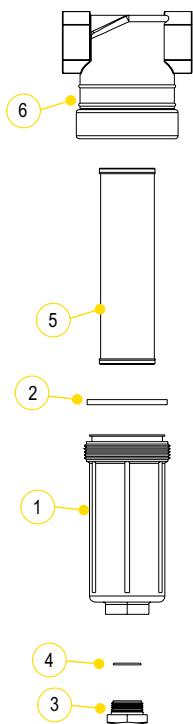

REPLACEMENT PARTS			
ITEM	PART NO	DESCRIPTION	QTY
1	LST200-B	2" POLY BOWL (CONTAINS #1, #3, #4)	1
2	LST200-GV	2" FKM GASKET	1
3	LSQ200-PL	1" CLEAN OUT PLUG	1
4	LSQ200-RV	FKM O-RING FOR CLEAN OUT PLUG	1
5	LST204SS	4 MESH SS SCREEN	1
5	LST206SS	6 MESH SS SCREEN	1
5	LST208SS	8 MESH SS SCREEN	1
5	LST210SS	10 MESH SS SCREEN	1
5	LST216SS	16 MESH SS SCREEN	1
5	LST230SS	30 MESH SS SCREEN	1
5	LST250SS	50 MESH SS SCREEN	1
5	LST280SS	80 MESH SS SCREEN	1
6	LST200-HSS	2" SS HEAD	1

## LSQ STRAINERS

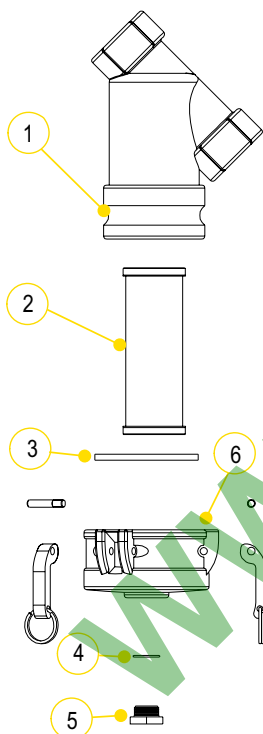

REPLACEMENT PARTS			
ITEM	PART NO	DESCRIPTION	QTY
1	LSQ200-B	2" LSQ BODY	1
2	LS206	6 MESH SCREEN	1
2	LS212	12 MESH SCREEN	1
2	LS220	20 MESH SCREEN	1
2	LS230	30 MESH SCREEN	1
2	LS250	50 MESH SCREEN	1
2	LS280	80 MESH SCREEN	1
2	LS2120	120 MESH SCREEN	1
3	LSQ200-G	2" EPDM GASKET	1
4	LSQ200R1	O-RING	1
5	N/A	3/4" CLEAN OUT PLUG	1
6	LSQ200-C	2" CAP (CONTAINS #3-6)	1

### SCREENS

MESH SIZE	RIB COLOR
6 MESH	WHITE
12 MESH	BLACK
20 MESH	BEIGE
30 MESH	FLAME RED
50 MESH	GENTIAN BLUE
80 MESH	ZINC YELLOW
120 MESH	BLACK

### STANDARD MESHES & DATA

	6 MESH	8 MESH	10 MESH	12 MESH	16 MESH	20 MESH	30 MESH	50 MESH	80 MESH	100 MESH	120 MESH
MICRONS	3360	2380	2000	1680	1190	841	595	297	177	149	116
WIRE DIAMETER	.035	.028	.025	.023	.018	.016	.012	.009	.0055	.0045	.0037
OPENING	.132	.097	.075	.060	.044	.034	.021	.011	.007	.005	.0046
% OPEN AREA	62.7	60.2	56.3	51.8	50.7	46.2	40.8	30.3	31.4	30.3	30.5

# LINE STRAINERS

## 1/2"-1 1/4" Y STRAINERS

### FEATURES

- Heavy duty glass reinforced polypropylene
- Corrosion resistant
- Easy grip end cap
- Heavy duty end cap threads
- Clean out plug
- Polypropylene ribbed 316 stainless steel screens
- EPDM gaskets
- Convenient color coded screens for easy mesh size identification (Refer to chart on next page)



### 1/2"-3/4" Y STRAINERS

PART NO	DESCRIPTION	MAX PSI	QTY
LS050-20	1/2" X 1/2" FP Y STRAINER W/20 MESH SS SCREEN	225	1
LS050-40	1/2" X 1/2" FP Y STRAINER W/40 MESH SS SCREEN	225	1
LS050-80	1/2" X 1/2" FP Y STRAINER W/80 MESH SS SCREEN	225	1
LS075-20	3/4" X 3/4" Y STRAINER W/20 MESH SS SCREEN	225	1
LS075-40	3/4" X 3/4" Y STRAINER W/40 MESH SS SCREEN	225	1
LS075-80	3/4" X 3/4" Y STRAINER W/80 MESH SS SCREEN	225	1



### 1"-1 1/4" Y STRAINERS

PART NO	DESCRIPTION	MAX PSI	QTY
LS100-20	1" X 1" Y STRAINER W/20 MESH SS SCREEN	200	1
LS100-40	1" X 1" Y STRAINER W/40 MESH SS SCREEN	200	1
LS100-80	1" X 1" Y STRAINER W/80 MESH SS SCREEN	200	1
LS125-20	1 1/4" X 1 1/4" Y STRAINER W/20 MESH SS SCREEN	200	1
LS125-40	1 1/4" X 1 1/4" Y STRAINER W/40 MESH SS SCREEN	200	1
LS125-80	1 1/4" X 1 1/4" Y STRAINER W/80 MESH SS SCREEN	200	1



## 1/2"-1 1/4" Y STRAINERS

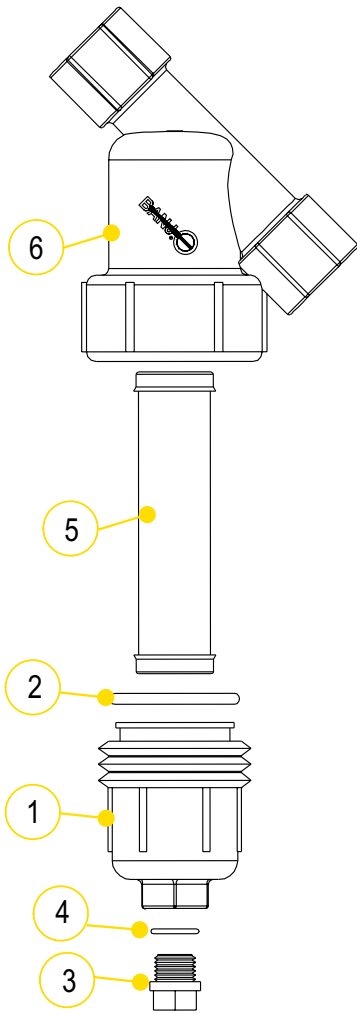

### REPLACEMENT PARTS

ITEM	PART NO	DESCRIPTION	QTY
1	N/A	1/2"-3/4" END CAP (CONTAINS #1, #3, #4)	1
2	LS075-G	1/2"-3/4" O-RING	1
3	12723	1/4" DRAIN PLUG (FITS 1/2"-3/4")	1
4	12724	1/2"-3/4" EPDM O-RING FOR DRAIN PLUG	1
5	LS720	1/2"-3/4" 20 MESH SCREEN	1
5	LS740	1/2"-3/4" 40 MESH SCREEN	1
5	LS780	1/2"-3/4" 80 MESH SCREEN	1
6	LS075-B	3/4" Y BODY	1
N/S	LS050B/C1	1/2" Y BODY, CAP & GASKET	1
N/S	LS075B/C1	3/4" Y BODY, CAP & GASKET	1

### SCREENS

MESH SIZE	RIB COLOR
6 MESH	WHITE
12 MESH	BLACK
20 MESH	BEIGE
30 MESH	FLAME RED
40 MESH	BROWN
50 MESH	GENTIAN BLUE
60 MESH	GENTIAN BLUE
80 MESH	ZINC YELLOW
100 MESH	TRAFFIC GREEN
120 MESH	BLACK

### REPLACEMENT PARTS

ITEM	PART NO	DESCRIPTION	QTY
1	LS100-C1	1"-1 1/4" END CAP (CONTAINS #1, #3, #4)	1
2	LS100-G	1"-1 1/4" O-RING	1
2	LS100-GV	1"-1 1/4" FKM GASKET	1
3	12777	1/2" PLUG (FITS 1"-1 1/4")	1
4	UV15163	EPDM O-RING FOR DRAIN PLUG	1
4	UV15163V	FKM O-RING FOR DRAIN PLUG	1
5	LS120	1"-1 1/4" 20 MESH SCREEN	1
5	LS140	1"-1 1/4" 40 MESH SCREEN	1
5	LS180	1"-1 1/4" 80 MESH SCREEN	1
6	LS100-B	1" Y BODY	1
6	LS125-B	1 1/4" Y BODY	1
N/S	LS100B/C1	1" Y BODY, CAP & GASKET	1
N/S	LS125B/C1	1 1/4" Y BODY, CAP & GASKET	1

### STANDARD MESHES & DATA

	6 MESH	8 MESH	10 MESH	12 MESH	16 MESH	20 MESH	30 MESH	50 MESH	80 MESH	100 MESH	120 MESH
MICRONS	3360	2380	2000	1680	1190	841	595	297	177	149	116
WIRE DIAMETER	.035	.028	.025	.023	.018	.016	.012	.009	.0055	.0045	.0037
OPENING	.132	.097	.075	.060	.044	.034	.021	.011	.007	.005	.0046
% OPEN AREA	62.7	60.2	56.3	51.8	50.7	46.2	40.8	30.3	31.4	30.3	30.5

# LINE STRAINERS

## 1½"-2" Y STRAINERS

### FEATURES

- Heavy duty glass reinforced polypropylene
- Corrosion resistant
- Easy grip end cap
- Heavy duty end cap threads
- Clean out plug
- Polypropylene ribbed 316 stainless steel screens
- EPDM gaskets
- Convenient color coded screens for easy mesh size identification (Refer to chart on next page)



### 1½" Y STRAINERS

PART NO	DESCRIPTION	MAX PSI	QTY
LS150-06	1½" X 1½" Y STRAINER W/6 MESH SS SCREEN	150	1
LS150-12	1½" X 1½" Y STRAINER W/12 MESH SS SCREEN	150	1
LS150-20	1½" X 1½" Y STRAINER W/20 MESH SS SCREEN	150	1
LS150-30	1½" X 1½" Y STRAINER W/30 MESH SS SCREEN	150	1
LS150-50	1½" X 1½" Y STRAINER W/50 MESH SS SCREEN	150	1
LS150-80	1½" X 1½" Y STRAINER W/80 MESH SS SCREEN	150	1
LS150-120	1½" X 1½" Y STRAINER W/120 MESH SS SCREEN	150	1



### 2" Y STRAINERS

PART NO	DESCRIPTION	MAX PSI	LOT QTY
LS200-06	2" X 2" Y STRAINER W/6 MESH POLY RIBBED SS SCREEN	150	1
LS200-12	2" X 2" Y STRAINER W/12 MESH POLY RIBBED SS SCREEN	150	1
LS200-20	2" X 2" Y STRAINER W/20 MESH POLY RIBBED SS SCREEN	150	1
LS200-30	2" X 2" Y STRAINER W/30 MESH POLY RIBBED SS SCREEN	150	1
LS200-50	2" X 2" Y STRAINER W/50 MESH POLY RIBBED SS SCREEN	150	5
LS200-80	2" X 2" Y STRAINER W/80 MESH POLY RIBBED SS SCREEN	150	1
LS200-100	2" X 2" Y STRAINER W/100 MESH POLY RIBBED SS SCREEN	150	1
LS200-120	2" X 2" Y STRAINER W/120 MESH POLY RIBBED SS SCREEN	150	1

WWW.BANJO.COM

## 1½"-2" Y STRAINERS

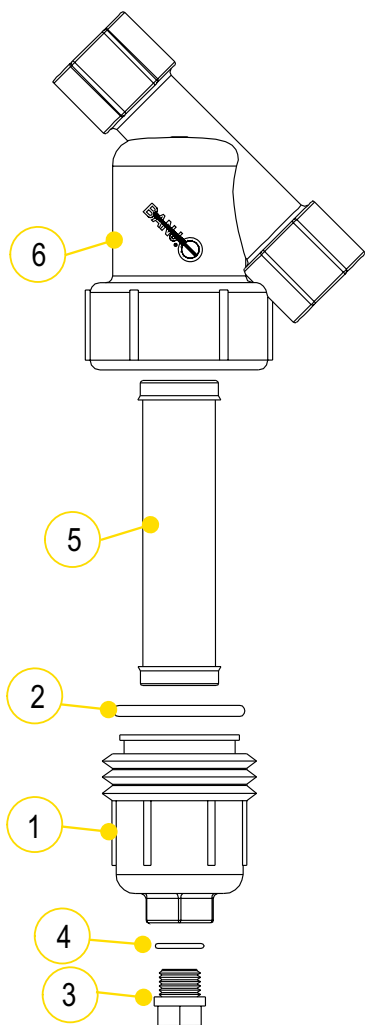

### REPLACEMENT PARTS

ITEM	PART NO	DESCRIPTION	QTY
1	LS150-C	1½" - 2" END CAP (CONTAINS #1, #3, #4)	1
2	LS150-G	1½"-2" O-RING	1
2	LS150-GV	1½"-2" FKM GASKET	1
3	LSQ200-PL	1" DRAIN PLUG (FITS 1½" - 2")	1
4	LSQ200-RV	1½"-2" FKM O-RING FOR DRAIN PLUG	1
5	LS206	1½"-2" 6 MESH SCREEN	1
5	LS212	1½"-2" 12 MESH SCREEN	1
5	LS220	1½"-2" 20 MESH SCREEN	1
5	LS230	1½"-2" 30 MESH SCREEN	1
5	LS250	1½"-2" 50 MESH SCREEN	1
5	LS280	1½"-2" 80 MESH SCREEN	1
5	LS2100	1½"-2" 100 MESH SCREEN	1
5	LS2120	1½"-2" 120 MESH SCREEN	1
5	LS250P	1½"-2" 50 MESH ALL POLY SCREEN	1
6	LS150-B	1½" Y BODY	1
6	LS200-B	2" Y BODY	1
N/S	LS150B/C	1½" Y BODY, CAP & GASKET	1
N/S	LS200B/C	2" Y BODY, CAP & GASKET	1

### SCREENS

MESH SIZE	RIB COLOR
6 MESH	WHITE
12 MESH	BLACK
20 MESH	BEIGE
30 MESH	FLAME RED
40 MESH	BROWN
50 MESH	GENTIAN BLUE
80 MESH	ZINC YELLOW
100 MESH	TRAFFIC GREEN
120 MESH	BLACK

### STANDARD MESHERS & DATA

	6 MESH	8 MESH	12 MESH	20 MESH	30 MESH	50 MESH	80 MESH	100 MESH	120 MESH
MICRONS	3360	2380	1680	841	595	297	177	149	116
WIRE DIAMETER	.035	.028	.023	.016	.012	.009	.0055	.0045	.0037
OPENING	.132	.097	.060	.034	.021	.011	.007	.005	.0046
% OPEN AREA	62.7	60.2	51.8	46.2	40.8	30.3	31.4	30.3	30.5

# LINE STRAINERS

## 3" Y STRAINERS

### FEATURES

- Heavy duty glass reinforced polypropylene
- Corrosion resistant
- High volume
- Heavy duty end cap threads
- ½" clean out plug
- 304 stainless steel screens
- EPDM gaskets
- Warning: to be used on suction side or non-pressure side in all applications



### 3" Y STRAINERS

PART NO	DESCRIPTION	MAX PSI	LOT QTY
LSM300-04	3" X 3" Y STRAINER W/4 MESH SCREEN	75	2/BOX
LSM300-08	3" X 3" Y STRAINER W/8 MESH SCREEN	75	2/BOX
LSM300-12	3" X 3" Y STRAINER W/12 MESH SCREEN	75	2/BOX
LSM300-20	3" X 3" Y STRAINER W/20 MESH SCREEN	75	2/BOX
LSM300-50	3" X 3" Y STRAINER W/50 MESH SCREEN	75	2/BOX

## 3" Y STAINLESS STEEL STRAINERS

### FEATURES

- Heavy duty stainless steel
- Corrosion resistant
- High volume
- Heavy duty end cap threads
- ½" clean out plug
- 304 stainless steel screens
- EPDM gaskets standard, FKM available
- Maximum operating pressure 225 psi
- Warning: to be used on suction side or non-pressure side in all applications



### 3" Y STRAINERS

PART NO	DESCRIPTION	QTY
LSS300-BC	3" SS BODY, CAP & GASKETS	1
LSS300-S	EPDM SCREEN SEAL	1
LSS300-SV	FKM SCREEN SEAL	1
LSS300-G	EPDM CAP GASKET	1
LSS300-GV	FKM CAP GASKET	1

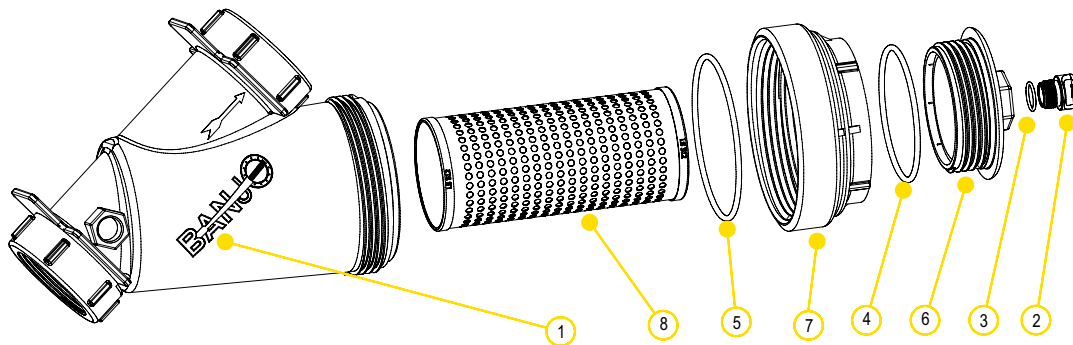

## 3" Y STRAINERS

- 304 stainless steel screens

### REPLACEMENT PARTS

ITEM	PART NO	DESCRIPTION	QTY
1	MLS300B1	3" BODY	1
2	13777	3/4" PLUG	1
3	13778	O-RING	1
4	MLS300ECG	EPDM END CAP GASKET	1
4	MLS300ECGV	FKM CAP GASKET	1
5	MLS300G	EPDM CAP GASKET	1
6	LS300EC	END CAP ONLY (PLUG SOLD SEPARATELY)	1
7	MLS300CAP	3" CAP	1
8	LS304	4 MESH SCREEN	1
8	LS308	8 MESH SCREEN	1
8	LS312	12 MESH SCREEN	1
8	LS320	20 MESH SCREEN	1
8	LS350	50 MESH SCREEN	1

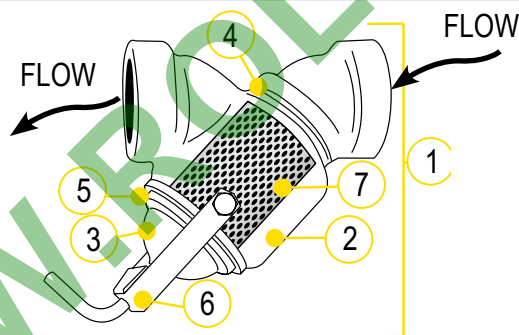

## 3" Y STAINLESS STEEL STRAINERS

- 304 stainless steel screens

### REPLACEMENT PARTS

ITEM	PART NO	DESCRIPTION	QTY
1	LSS300-BC	3" SS BODY, CAP & GASKETS	1
2	N/A	3" SS BODY	1
3	N/A	3" SS CAP	1
4	LSS300-S	EPDM SCREEN SEAL	1
4	LSS300-SV	FKM SCREEN SEAL	1
5	LSS300-G	EPDM CAP GASKET	1
5	LSS300-GV	FKM CAP GASKET	1
6	LSS300-H	HANDLE/CLAMP ASSEMBLY	1
7	LSS306	6 MESH SS SCREEN	1
7	LSS308	8 MESH SS SCREEN	1
7	LSS312	12 MESH SS SCREEN	1
7	LSS320	20 MESH SS SCREEN	1
7	LSS330	30 MESH SS SCREEN	1
7	LSS350	50 MESH SS SCREEN	1

# CENTRIFUGAL PUMPS

**PUMP ACCESSORIES**  
PAGES 95

ROLL CAGES  
SUCTION BASKET STRAINERS  
BASE PLATES

**2" POLY PUMPS**  
PAGES 96 - 109

GAS ENGINE PUMPS  
PUMP ONLY/ BEARING PEDESTAL  
WET SEAL WITH GAS ENGINE  
ELECTRIC MOTOR DRIVEN  
HYDRAULIC MOTOR DRIVEN  
MANIFOLD

**3" POLY PUMPS**  
PAGES 110- 119

GAS ENGINE PUMPS  
PUMP ONLY/ BEARING PEDESTAL  
MANIFOLD  
HYDRAULIC MOTOR DRIVEN  
WET SEAL WITH GAS ENGINE

**1½" & 2" CAST IRON PUMPS**  
PAGES 120 - 127

GAS ENGINE PUMPS  
PUMP ONLY/ BEARING PEDESTAL  
WET SEALS  
ELECTRIC MOTOR DRIVEN  
HYDRAULIC MOTOR DRIVEN

**2" CAST IRON 222  
SERIES PUMPS**  
PAGES 128- 131

GAS ENGINE PUMPS  
PUMP ONLY/ BEARING PEDESTAL  
HYDRAULIC MOTOR DRIVEN  
ELECTRIC MOTOR DRIVEN  
MANIFOLD WET SEAL

**3" CAST IRON PUMPS**  
PAGES 132 - 137

GAS ENGINE PUMPS  
PUMP ONLY/ BEARING PEDESTAL  
WET SEALS  
HYDRAULIC MOTOR DRIVEN

**3" CAST IRON 333  
SERIES PUMPS**  
PAGES 138 - 139

GAS ENGINE PUMPS  
PUMP ONLY/ BEARING PEDESTAL  
ELECTRIC MOTOR DRIVEN

**3" CAST IRON MANIFOLD WET  
SEAL M332 SERIES PUMPS**  
PAGES 140 - 143

GAS ENGINE PUMPS  
PUMP ONLY/ BEARING PEDESTAL  
ELECTRIC MOTOR DRIVEN  
HYDRAULIC MOTOR DRIVEN

**4" CAST IRON 444  
SERIES PUMPS**  
PAGES 144 - 145

GAS ENGINE PUMPS  
PUMP ONLY

**2" & 3" STAINLESS STEEL  
PUMPS**  
PAGES 146- 153

GAS ENGINE PUMPS  
PUMP ONLY/ BEARING PEDESTAL  
ELECTRIC MOTOR DRIVEN  
HYDRAULIC MOTOR DRIVEN

**ENGINE REFERENCE GUIDE**  
PAGE 154



## ROLL CAGE

### FEATURES

- Made of steel tube construction for stability
- Powder coated finish for durability
- Fits all 2" polypropylene pumps
- Unassembled

### PUMP ROLL CAGES

PART NO	DESCRIPTION	QTY
PRC200	2" PUMP ROLL CAGE	1



## SUCTION BASKET STRAINERS

### FEATURES

- Made of polyethylene
- Prevents plugging and damage to pump while suctioning from streams or ponds.

### SUCTION BASKET STRAINERS

PART NO	DESCRIPTION	QTY
200SBS	2" FEMALE THREAD POLY BASKET	1
300SBS	3" FEMALE THREAD POLY BASKET	1



## BASE PLATE ASSEMBLY

### FEATURES

- Universal fit for 1½", 2" and 3" polypropylene or cast iron pumps

### BASE PLATE ASSEMBLY

PART NO	DESCRIPTION	QTY
18700	BASE PLATE ASSEMBLY INCLUDES PLATE, COUPLING GUARD, BOLT BAG AND SHIMS	1

# CENTRIFUGAL PUMPS

## 2" POLY PUMPS

### FEATURES

- Precision molded construction
- Lightweight
- Corrosion resistant
- Superior design
- Low maintenance
- EPDM standard, FKM available
- Engine warranty service available at authorized Briggs & Stratton® and Honda® dealers



### 2" POLY PUMPS W/GAS ENGINES

PART NO	DESCRIPTION	HP	QTY
200PH-5	2" POLY PUMP W/5.5 HP HONDA® ENGINE	5.5	1
200PH-5E	2" POLY PUMP W/5.5 HP HONDA® ENGINE W/ ELECTRIC START	5.5	1
200PH-5V	2" POLY PUMP W/5.5 HP HONDA® ENGINE W/FKM & 316 SS SEAL	5.5	1
200PH6	2" POLY PUMP W/6.5 HP HONDA® ENGINE	6.5	1
200P6PRO	2" POLY PUMP W/6.5 HP BRIGGS & STRATTON® ENGINE PRO SERIES	6.5	1
200P6PROE	2" POLY PUMP W/6.5 HP BRIGGS & STRATTON® ENGINE PRO SERIES W/ELECTRIC START	6.5	1
200P6PROV	2" POLY PUMP W/6.5 HP BRIGGS & STRATTON® ENGINE PRO SERIES W/FKM & 316 SS SEAL	6.5	1



WARNING! DO NOT RUN PUMP DRY, RESTRICT OR REDUCE PORT SIZES OR DEAD HEAD PUMP



WARNING! DO NOT USE WITH FLAMMABLE LIQUIDS



### 2" POLY PUMP BEARING PEDESTALS

PART NO	DESCRIPTION	HP	QTY
200PB	2" POLY BEARING PEDESTAL W/ 3/4" SHAFT & 3 VANE IMPELLER	N/A	1
205PB	2" POLY BEARING PEDESTAL W/ 3/4" SHAFT & 5 VANE IMPELLER	N/A	1
205PB-V	2" POLY BEARING PEDESTAL W/ 3/4" SHAFT & 5 VANE IMPELLER W/FKM & 316 SS SEAL	N/A	1



### 2" POLY PUMP ONLYS

PART NO	DESCRIPTION	HP	QTY
200PO	2" POLY PUMP ONLY* W/ 3 VANE IMPELLER	N/A	1
200PO-V	2" POLY PUMP ONLY* W/3 VANE IMPELLER W/ FKM & 316 SS SEAL	N/A	1
205PO	2" POLY PUMP ONLY* W/ 5 VANE IMPELLER	N/A	1
205PO-V	2" POLY PUMP ONLY* W/ 5 VANE IMPELLER W/ FKM & 316 SS SEAL	N/A	1

Note: Requires 3/4" shaft on motor



## 2" POLY PUMPS

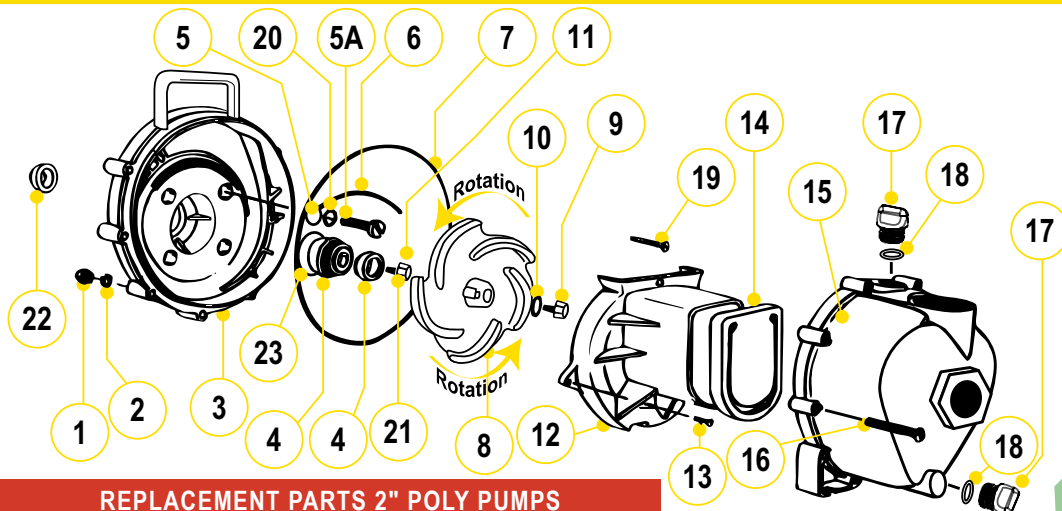

### REPLACEMENT PARTS 2" POLY PUMPS

ITEM	PART NO	DESCRIPTION	QTY
1	V07019	SS BODY NUTS	10
2	V07018	SS LOCK WASHERS	10
3	12703A	POLY PUMP REAR BRACKET	1
4	12713	SEAL ASSEMBLY	1
4	12713V	FKM SEAL ASSEMBLY	1
5	12717	O-RING FOR SCREW HEAD	4
5	12717V	FKM O-RING FOR SCREW HEAD	4
5A	12715A	SS BRACKET SCREWS	4
6	12754	O-RING SEGMENT	1
6	12754V	FKM O-RING SEGMENT	1
7	12719A	BODY O-RING	1
7	12719AV	FKM BODY O-RING	1
8	12772	5 VANE IMPELLER	1
8	12771A	3 VANE IMPELLER	1
9	12765A	SS IMPELLER BOLT	1
10	A204	O-RING	1
10	A204V	FKM O-RING	1
11	12775A	IMPELLER HEX NUT	1
12	12702A	POLY PUMP VOLUTE	1
13	12725	SS VOLUTE SCREWS	2
14	12705	POLY PUMP CHECK VALVE	1
14	12705V	FKM CHECK VALVE	1
15	12712A	BODY ASSEMBLY	1
16	12720	SS BODY SCREWS	10
17	12777	1/2" PLUG	2
18	UV15163	PRIME/DRAIN PLUG O-RING	2
18	UV15163V	FKM PRIME/DRAIN PLUG O-RING	2
19	12900	SS UPPER VOLUTE SCREW	1
20	12901	SS REAR BRACKET WASHER	4
21	12902A	IMPELLER KEY	1
22	12716	POLY PUMP SLINGER	1
23	12710	O-RING FOR SEAL ASSEMBLY	1
23	12710V	FKM O-RING FOR SEAL ASSEMBLY	1
N/S	12882A	BEARING PEDESTAL	1
N/S	12099	7/16"-14 X 1.25" HHCS	1
KIT	12000A	POLY PUMP EPDM REPAIR KIT (ITEMS 4-8, 10, 14, 18, 22, 23 & 12099)	1
KIT	12000AV	POLY PUMP FKM REPAIR KIT (ITEMS 4-8, 10, 14, 18, 22, 23 & 12099)	1
KIT	12999A	PUMP SEAL/O-RING KIT (ITEMS 5-7, 10, 18, 22, 23 & 12099)	1
KIT	12999AV	FKM PUMP SEAL/O-RING KIT (ITEMS 5-7, 10, 18, 22, 23 & 12099)	1

### KITS 2" POLY PUMPS

PART NO	REPAIR KIT NO	SEAL KIT NO
200PH-5	12000A	12999A
200PH-5E	12000A	12999A
200PH-5V	12000AV	12999AV
200PH6	12000A	12999A
200P6PRO	12000A	12999A
200P6PROE	12000A	12999A
200P6PROV	12000AV	12999AV
200PB	12003A	12999A
205PB	12000A	12999A
205PB-V	12000AV	12999AV
200PO	12003A	12999A
200PO-V	12003AV	12999AV
205PO	12000A	12999A
205PO-V	12000AV	12999AV

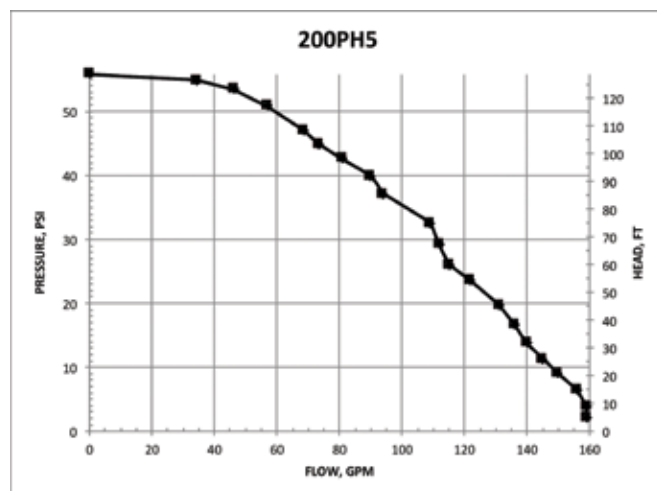
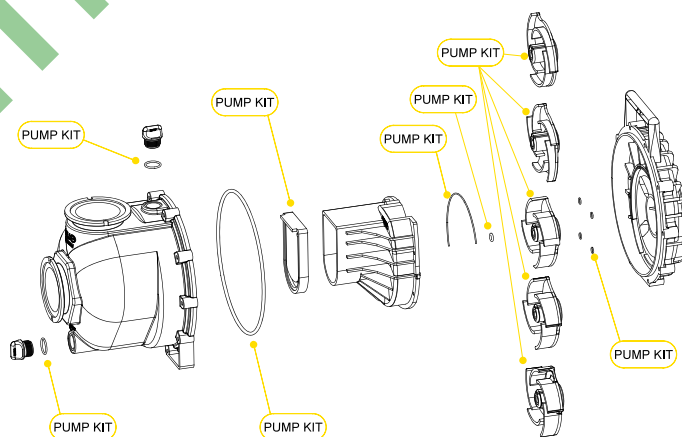

# CENTRIFUGAL PUMPS

## 2" POLY WET SEAL PUMPS

### FEATURES

- Run dry capability
- Double seal contained in ethylene glycol reservoir. Carbon ceramic seal faces with stainless steel cup and spring with EPDM rubber.
- Pump end separated from engine
- V-shaped for quicker priming
- Engine warranty service available at authorized Briggs & Stratton® and Honda® dealers



WARNING! DO NOT USE WITH  
FLAMMABLE LIQUIDS

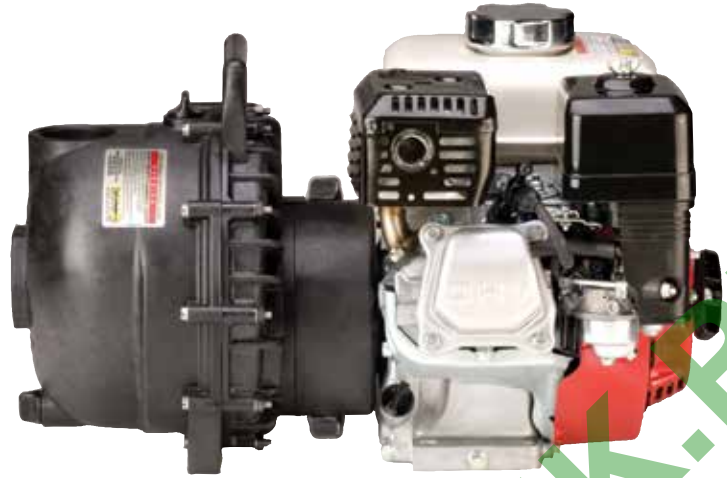

### 2" POLY WET SEAL PUMPS W/GAS ENGINES

PART NO	DESCRIPTION	HP	QTY
200PH5W	2" POLY WET SEAL PUMP W/5.5 HP HONDA® ENGINE	5.5	1



### 2" POLY WET SEAL PUMP ONLY

PART NO	DESCRIPTION	HP	QTY
205POW	2" POLY WET SEAL PUMP ONLY, 5 VANE IMPELLER WITH EPDM SEALS	N/A	1

# CENTRIFUGAL PUMPS

## 2" POLY WET SEAL PUMPS

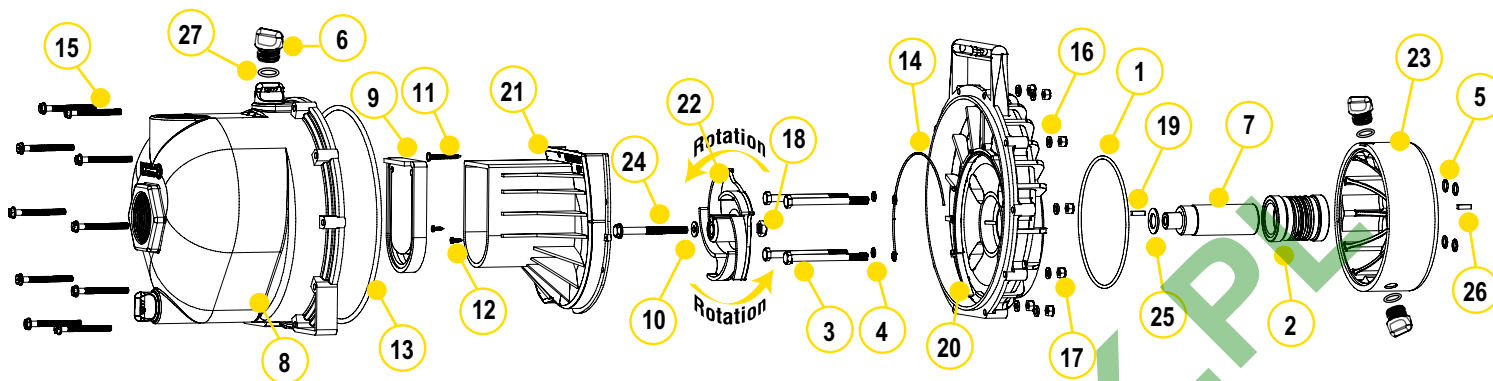

### REPLACEMENT PARTS 2" POLY PUMPS

ITEM	PART NO	DESCRIPTION	QTY
1	13719	O-RING	1
2	15035E	EPDM MECHANICAL SEAL ASSEMBLY	1
3	13034	5/16" -24 X 3 3/4" HHCS	4
4	12717	O-RING FOR BRACKET SCREW	4
5	12709	O-RING	4
6	12777	1/2" PLUG	4
7	12155	ADAPTER SHAFT	1
8	12712A	BODY ASSEMBLY	1
9	12705	CHECK VALVE	1
10	A204	IMPELLER BOLT GASKET	1
11	12900	#10 X 1 1/2" PPH SMS	1
12	12725	#6 X 1/2" PPH SMS	2
13	12719A	BODY O-RING	1
14	12754	O-RING SEGMENT	1
15	12720	1/4" - 20 X 2 1/2" SL IND HWHS	10
16	V07018	1/4" LOCK WASHER	10
17	V07019	1/4" - 20 HEX NUT	10
18	12775A	7/16" - 14 HEX NUT	1
19	12902A	3/16" SQ. X 5/8" KEY	2
20	12707W	WET SEAL REAR BRACKET	1
21	12702A	VOLUTE	1
22	12772	5 VANE IMPELLER	1
23	12202W	WET SEAL RESERVOIR	1
24	12766	5/16" - 24 X 3 1/4" HFS	1
25	CV10175	GASKET	1
26	12902A	1/4" SQ. 3/4" KEY STOCK	1
27	UV15163	O-RING FOR DRAIN PLUG	4
KIT	12000A	POLY PUMP EPDM REPAIR KIT (ITEMS 4-8, 10, 14, 18, 22, 23 & 12099)	1
KIT	12000AV	POLY PUMP FKM REPAIR KIT (ITEMS 4-8, 10, 14, 18, 22, 23 & 12099)	1

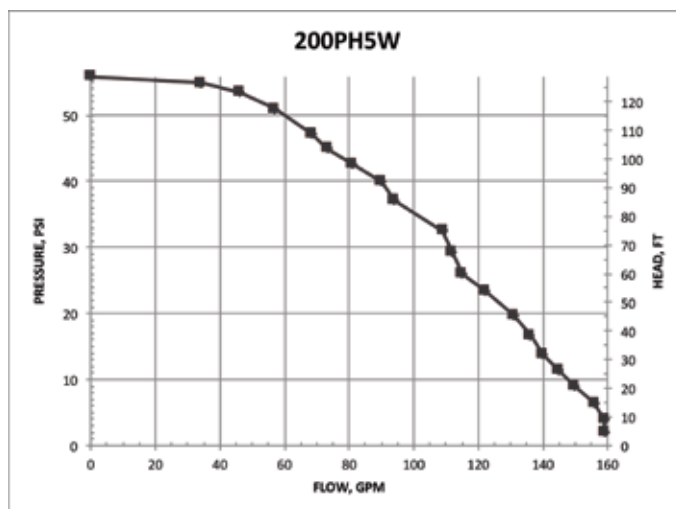
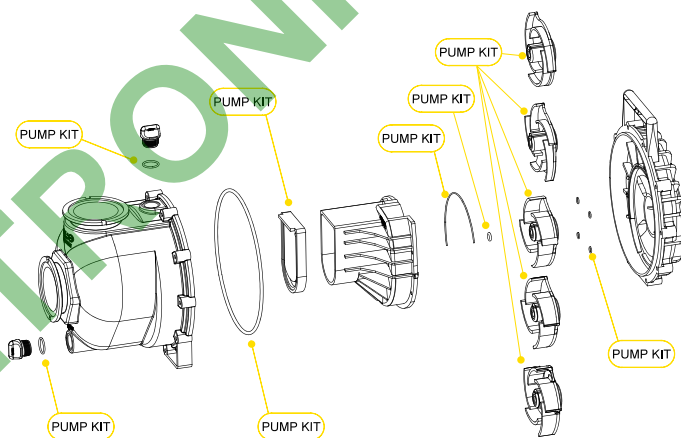

# CENTRIFUGAL PUMPS

## 2" POLY PUMPS WITH ELECTRIC MOTORS

### FEATURES

- Additional drive unit protection with added 1" spacer for ultimate protection
- The "Super Slinger" included for even more drive unit protection (not shown)



### 2" POLY PUMPS W/ELECTRIC MOTORS

PART NO	DESCRIPTION	HP	QTY
234PPE5	2" POLY PUMP W/5 HP THREE PHASE ELECTRIC MOTOR W/ EPDM ELASTOMERS	5	1
234PPE5V	2" POLY PUMP W/5 HP THREE PHASE ELECTRIC MOTOR W/FKM ELASTOMERS	5	1
234PPE51	2" POLY PUMP W/5 HP SINGLE PHASE ELECTRIC MOTOR W/ EPDM ELASTOMERS	5	1
234PPE51V	2" POLY PUMP W/5 HP SINGLE PHASE ELECTRIC MOTOR W/FKM ELASTOMERS	5	1



WARNING! DO NOT RUN PUMP DRY, RESTRICT OR REDUCE PORT SIZES OR DEAD HEAD PUMP



WARNING! DO NOT USE WITH FLAMMABLE LIQUIDS

# CENTRIFUGAL PUMPS

2" POLY PUMPS WITH ELECTRIC MOTORS

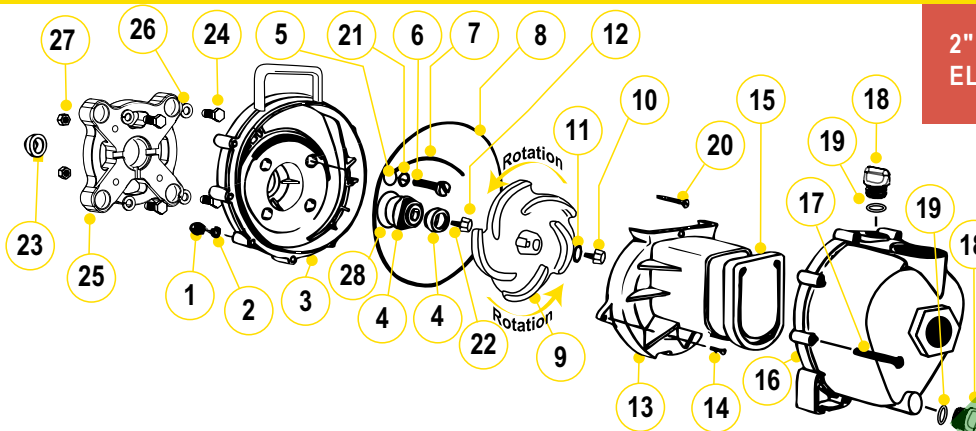

## REPLACEMENT PARTS 2" POLY PUMPS

ITEM	PART NO	DESCRIPTION	QTY
1	V07019	SS BODY NUTS	10
2	V07018	SS LOCK WASHERS	10
3	12703A	POLY PUMP REAR BRACKET	1
4	12713	SEAL ASSEMBLY EPDM	1
4	12713V	SEAL ASSEMBLY FKM	1
5	12717	SCREW HEADS O-RING EPDM	4
5	12717V	SCREW HEADS O-RING FKM	4
6	N/A	SS BRACKET SCREWS	4
7	12754	O-RING SEGMENT EPDM	1
7	12754V	O-RING SEGMENT FKM	1
8	12719A	BODY O-RING EPDM	1
8	12719AV	BODY O-RING FKM	1
9	12772	5 VANE IMPELLER	1
10	12765A	SS IMPELLER BOLT	1
11	A204	O-RING	1
11	A204V	FKM O-RING	1
12	12775A	IMPELLER HEX NUT	1
13	12702A	POLY PUMP VOLUTE	1
14	12725	SS VOLUTE SCREWS	2
15	12705	POLY PUMP CHECK VALVE EPDM	1
15	12705V	POLY PUMP CHECK VALVE FKM	1
16	12712A	BODY ASSEMBLY EPDM	1
16	N/A	BODY ASSEMBLY FKM	1
17	12720	SS BODY SCREWS	10
18	12777	1/2" PLUG	2
19	UV15163	PRIME/DRAIN PLUG O-RING	2
19	UV15163V	FKM PRIME/DRAIN PLUG O-RING	2
20	12900	SS UPPER VOLUTE SCREW	1
21	12901	SS REAR BRACKET WASHER	4
22	12902A	IMPELLER KEY	1
23	12716	PUMP SLINGER	1
24	17704	3/8"-16 X 1.25" HHCS	8
25	12046	56C FRAME ADAPTER	1
26	V20018	LOCK WASHER FOR 56C FRAME ADAPTER	8
27	V10119	NUT FOR 56C FRAME ADAPTER	4
28	12710	O-RING FOR SEAL ASSEMBLY	1
28	12710V	FKM O-RING FOR SEAL ASSEMBLY	1

## REPLACEMENT PARTS 2" POLY PUMPS

ITEM	PART NO	DESCRIPTION	QTY
N/S	17701	BASE PLATE	1
N/S	12099	7/16"-14 X 1.25" HHCS	1
N/S	12052	56C FRAME ADAPTER SHAFT FOR 200PEO	1
KIT	12756	56C FRAME ADAPTER KIT (ITEMS 6, 22, 24-27, 12052, 12053, 15751, 15752)	1
KIT	12000A	POLY PUMP EPDM REPAIR KIT (ITEMS 4, 5, 7, 8, 9, 11, 15, 19, 23 & 12099)	1
KIT	12000AV	POLY PUMP FKM REPAIR KIT (ITEMS 4, 5, 7, 8, 9, 11, 15, 19, 23 & 12099)	1
KIT	12999A	PUMP SEAL/O-RING KIT (ITEMS 4, 5, 7, 8, 11, 19, 23)	1
KIT	12999AV	FKM PUMP SEAL/O-RING KIT (ITEMS 4, 5, 7, 8, 11, 19, 23)	1

## KITS 2" POLY PUMPS

PART NO	REPAIR KIT NO	SEAL KIT NO	FRAME ADAPTER KIT
234PPE5	12000A	12999A	12756
234PPE5V	12000AV	12999AV	12756
234PPE51	12000A	12999A	12756
234PPE51V	12000AV	12999AV	12756

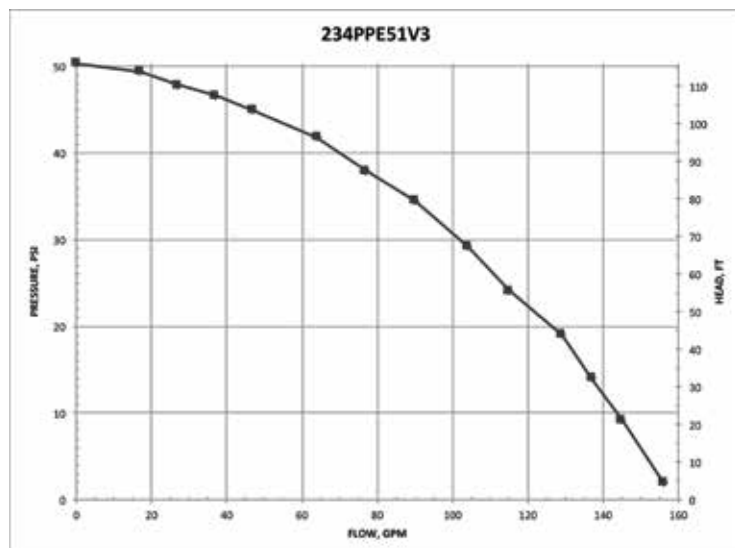

# CENTRIFUGAL PUMPS

## 2" POLY PUMPS WITH HYDRAULIC MOTORS

### FEATURES

- Precision molded construction
- Lightweight
- Corrosion resistant
- Low maintenance
- Hydraulic fluid capacity is minimum 6 gallons and maximum 10 gallons
- Open or closed system
- 3600 R.P.M.
- Recommendation to use the motor spool control valve or a suitable equivalent. The lack of such a valve in this circuit may cause failure to the hydraulic motor.



### 2" POLY PUMPS W/HYDRAULIC MOTORS

PART NO	DESCRIPTION	HP	QTY
200PHA	2" POLY PUMP WITHOUT HYDRAULIC MOTOR	N/A	1
200PHY	2" POLY PUMP W/12 HP HYDRAULIC MOTOR	12.0	1
200PHAW	2" POLY WET SEAL PUMP WITHOUT HYDRAULIC MOTOR	N/A	1



**WARNING! DO NOT RUN PUMP DRY, RESTRICT OR REDUCE PORT SIZES OR DEAD HEAD PUMP**



**WARNING! DO NOT USE WITH FLAMMABLE LIQUIDS**

### SPOOL VALVE ASSEMBLY DIAGRAM

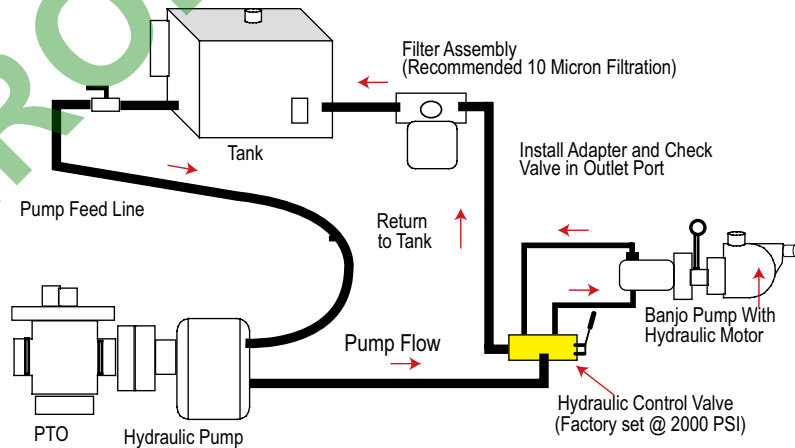

### HYDRAULIC MOTOR SPOOL VALVE

PART NO	DESCRIPTION	HP	QTY
HSV1000	HYDRAULIC MOTOR SPOOL VALVE	N/A	1

# CENTRIFUGAL PUMPS

## 2" POLY PUMPS WITH HYDRAULIC MOTORS

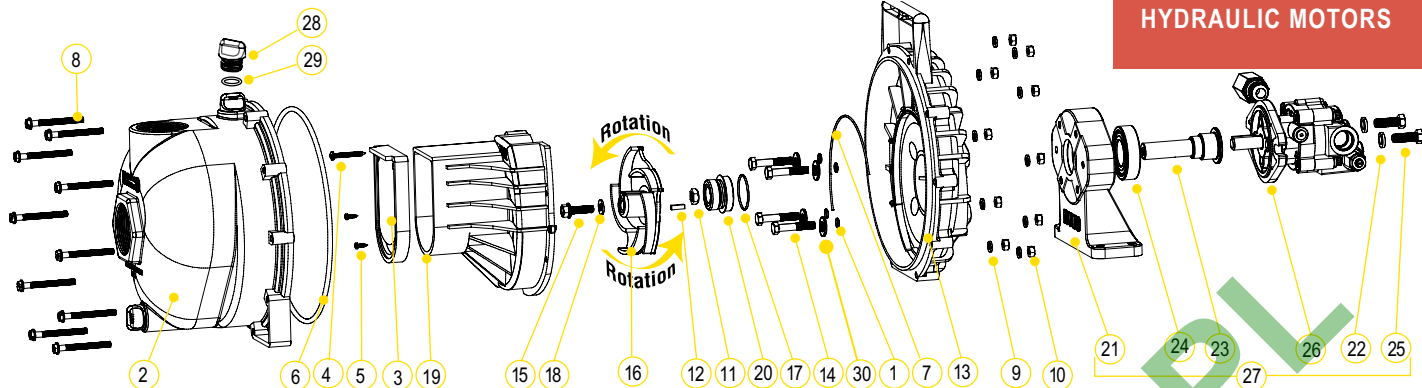

### REPLACEMENT PARTS 2" POLY PUMPS

ITEM	PART NO	DESCRIPTION	QTY
1	12717	O-RING FOR SCREW HEADS	4
2	12712A	BODY ASSEMBLY	1
3	12705	CHECK VALVE	1
4	12900	SS UPPER VOLUTE SCREW	1
5	12725	SS VOLUTE SCREWS	2
6	12719A	BODY O-RING	1
7	12754	O-RING SEGMENT	1
8	12720	SS BODY SCREWS	10
9	V07018	SS LOCK WASHERS	10
10	V07019	SS BODY NUTS	10
11	12775A	IMPELLER HEX NUT	1
12	12902A	IMPELLER KEY	1
13	12703A	POLY PUMP REAR BRACKET	1
14	12715A	5/16"-24 X 1.75" HHCS	4
15	12765A	SS IMPELLER BOLT	1
16	12772	5 VANE IMPELLER	1
17	12710	O-RING FOR SEAL ASSEMBLY	1
18	A204	O-RING	1
19	12702A	POLY PUMP VOLUTE	1
20	12713	MECHANICAL SEAL ASSEMBLY	1
21	12049E	HYDRAULIC PEDESTAL HOUSING	1
22	V20018	3/8" LOCK WASHER	2
23	12055E	ADAPTER SHAFT	1
24	17056E	BEARING	1
25	18010SS	3/8"-16 X 1.25" HHCS	2
26	HY1013	HYDRAULIC MOTOR	1
27	12600B	COMPLETE HYDRAULIC ASSEMBLY	1
28	12777	1/2" PLUG	2
29	UV15163	O-RING FOR PLUG	2
30	12901	WASHER (200PHA & 200PHY)	4
N/S	HY1003	HYDRAULIC MOTOR SEAL KIT	1
KIT	12000A	POLY PUMP EPDM REPAIR KIT (ITEMS 1, 3, 6, 7, 16-18, 20, 12099)	1
KIT	12999A	PUMP SEAL/O-RING KIT (ITEMS 1, 6, 7, 17, 20, 29, 12099)	1

### KITS 2" POLY PUMPS

PART NO	EPDM REPAIR KIT NO	EPDM SEAL KIT NO	HYDRAULIC MOTOR SEAL KIT
200PHA	12000A	12999A	N/A
200PHY	12000A	12999A	HY1003

### HYDRAULIC MOTOR DATA

U.S. GALLONS/REV.	0.0025
CUBIC INCHES/REV.	0.580
LITERS/REV.	0.0097
MAX HYDRAULIC PRESSURE	2000 PSI
MIN HYDRAULIC PRESSURE	200 PSI
INLET PORT	SAE 10 (7/8-14 UNF-2B)
OUTLET PORT	SAE 10 (7/8-14 UNF-2B)
MINIMUM GPM REQUIRED	6 GPM 2400 RPM
MAXIMUM GPM REQUIRED	10 GPM 4000 RPM
IDEAL GPM REQUIRED	9 GPM 3600 RPM

### CONNECTION INFORMATION

INLET	"A" PORT
OUTLET	"B" PORT

SUPPLIED CHECK VALVE IS TO ENSURE PROPER ROTATION OF THE BANJO PUMP. PLACE CHECK VALVE IN OUTLET PORT (MARKED "B") FOR PROPER RIGHT HAND ROTATION.

### SPOOL VALVE INFORMATION

REQUIRED OUTLET FLOW	MIN 6 GPM / MAX 10 GPM
REQUIRED SYSTEM PRESSURE	MIN 600 PSI / MAX 3000 PSI

### 200PHYW

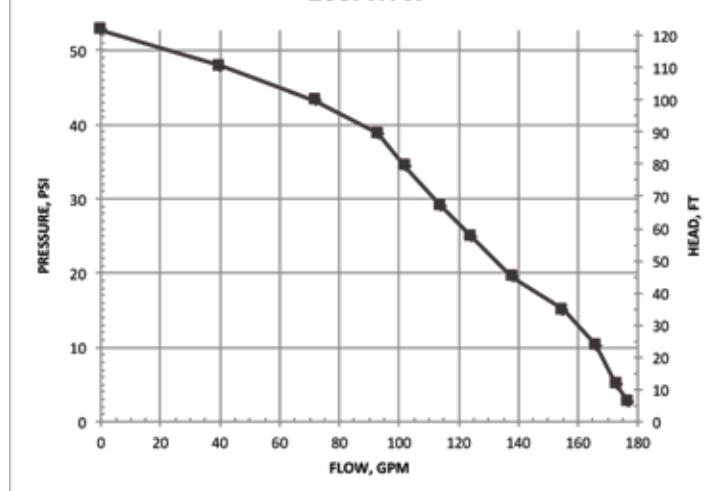

# CENTRIFUGAL PUMPS

## 2" POLY MANIFOLD PUMPS WITH GAS ENGINES

### FEATURES

- Precision molded construction
- Lightweight
- Corrosion resistant
- Low maintenance
- See pages 39-45 on manifold fittings for easy plumbing.



### 2" POLY MANIFOLD PUMPS W/GAS ENGINES

PART NO	DESCRIPTION	HP	QTY
M220PH5	2" POLY MANIFOLD PUMP W/5.5 HP HONDA® ENGINE	5.5	1
M220PH6	2" FP MANIFOLD PUMP W/6.5 HP HONDA® ENGINE	6.5	1
M220P6PRO	2" FP MANIFOLD PUMP W/6.5 HP BRIGGS & STRATTON® PRO SERIES ENGINE	6.5	1



WARNING! DO NOT RUN PUMP DRY, RESTRICT OR REDUCE PORT SIZES OR DEAD HEAD PUMP



WARNING! DO NOT USE WITH FLAMMABLE LIQUIDS



### 2" POLY MANIFOLD BEARING PEDESTAL

PART NO	DESCRIPTION	HP	QTY
M220PB	2" POLY MANIFOLD BEARING PEDESTAL W/ 3/4" SHAFT & 3 VANE IMPELLER	N/A	1



### 2" POLY MANIFOLD PUMP ONLY

PART NO	DESCRIPTION	HP	QTY
M225PO	2" POLY MANIFOLD PUMP ONLY W/ 3/4" SHAFT & 5 VANE IMPELLER	N/A	1



# CENTRIFUGAL PUMPS

2" POLY MANIFOLD PUMPS WITH GAS ENGINES

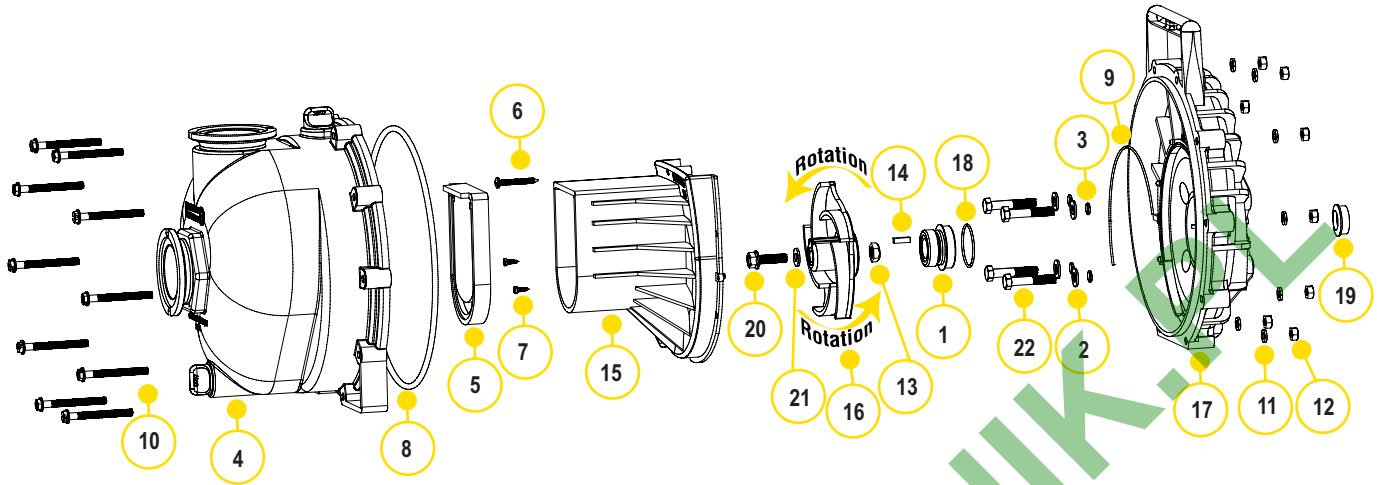

## REPLACEMENT PARTS 2" POLY PUMPS

ITEM	PART NO	DESCRIPTION	QTY
1	12713	MECHANICAL SEAL ASSEMBLY	1
2	12901	SS REAR BRACKET WASHER	4
3	12717	O-RING FOR SCREW HEAD	4
4	M12712	2" FP MANIFOLD PUMP BODY ASSEMBLY	1
5	12705	POLY PUMP CHECK VALVE	1
6	12900	SS UPPER VOLUTE SCREW	1
7	12725	SS VOLUTE SCREWS	2
8	12719A	BODY O-RING	1
9	12754	O-RING SEGMENT	1
10	12720	SS BODY SCREWS	10
11	V07018	SS LOCK WASHERS	10
12	V07019	SS BODY NUTS	10
13	12775A	IMPELLER HEX NUT	1
14	12902A	IMPELLER KEY	1
15	12702A	POLY PUMP VOLUTE	1
16	12772	5 VANE IMPELLER	1
16	12771A	3 VANE IMPELLER	1
17	12703A	POLY PUMP REAR BRACKET	1
18	12710	O-RING FOR SEAL ASSEMBLY	1
19	12716	POLY PUMP SLINGER	1
20	12765A	SS IMPELLER BOLT	1
21	A204	O-RING	1
22	12715A	SS BRACKET SCREWS	4
KIT	12000A	POLY PUMP EPDM REPAIR KIT (ITEMS 2,4,7,8,17,19,21,30, 12099)	1
KIT	12000AV	POLY PUMP FKM REPAIR KIT (ITEMS 2,4,7,8,17,19,21,30, 12099)	1
KIT	12999A	PUMP SEAL/O-RING KIT (ITEMS 2,4,7,8,17,19,21,30, 12099)	1
KIT	12999AV	FKM PUMP SEAL/O-RING KIT (ITEMS 4-7,8,10,18, 23 & 12099)	1

## KITS 2" POLY PUMPS

PART NO	EPDM REPAIR KIT NO	FKM REPAIR KIT NO	EPDM SEAL KIT NO	FKM SEAL KIT NO
M220PH5	12000A	12000AV	12999A	12999AV
M220PH5E	12000A	12000AV	12999A	12999AV
M220PH6	12000A	12000AV	12999A	12999AV
M220P6PRO	12000A	12000AV	12999A	12999AV
M220P6PROE	12000A	12000AV	12999A	12999AV
M220PB	12003A	12003AV	12999A	12999AV
M220PO	12003A	12003AV	12999A	12999AV

SEE 12000A & 12000AV KIT DRAWING ON PAGE 99

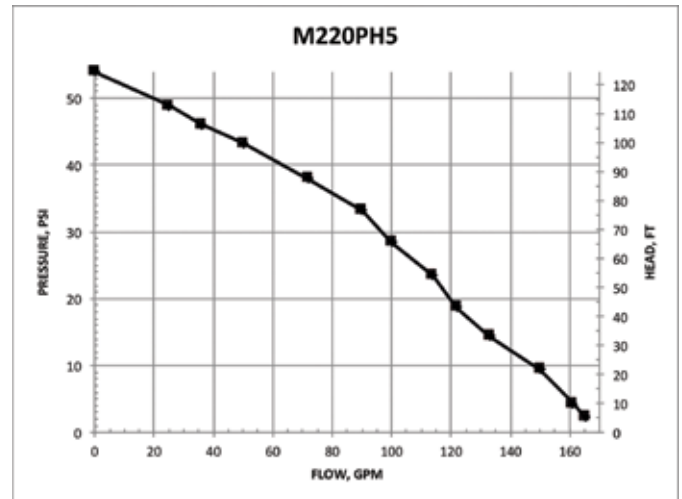

# CENTRIFUGAL PUMPS

## 2" POLY MANIFOLD WET SEAL PUMPS

### FEATURES

- Run dry capability
- Double seal contained in ethylene glycol reservoir. Carbon ceramic seal faces with stainless steel cup and spring with EPDM rubber
- Pump end separated from engine
- Large weep holes between pump and engine
- V-shaped for quicker priming
- See pages 39-45 on manifold fittings for easy plumbing.



### 2" POLY MANIFOLD WET SEAL PUMPS W/GAS ENGINES

PART NO	DESCRIPTION	HP	QTY
M220PH5W	2" POLY MANIFOLD WET SEAL PUMP W/5.5 HP HONDA® ENGINE	5.5	1



WARNING! DO NOT RUN PUMP DRY, RESTRICT OR REDUCE PORT SIZES OR DEAD HEAD PUMP



WARNING! DO NOT USE WITH FLAMMABLE LIQUIDS

# CENTRIFUGAL PUMPS

## 2" POLY MANIFOLD WET SEAL PUMPS

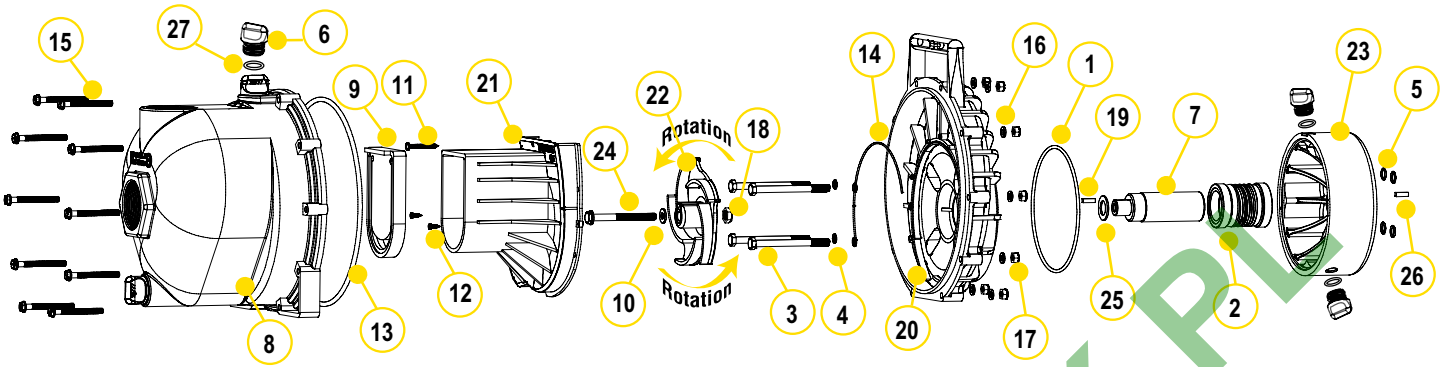

### REPLACEMENT PARTS 2" POLY PUMPS

ITEM	PART NO	DESCRIPTION	QTY
1	13719	O-RING	1
2	15035E	EPDM MECHANICAL SEAL ASSEMBLY	1
3	13034	5/16" -24 X 3 3/4" HHCS	4
4	12717	O-RING FOR BRACKET SCREW	4
5	12709	O-RING	4
6	12777	1/2" PLUG	4
7	12155	ADAPTER SHAFT	1
8	M12712	2" FP MANIFOLD PUMP BODY ASSEMBLY	1
9	12705	CHECK VALVE	1
10	A204	IMPELLER BOLT GASKET	1
11	12900	#10 X 1 1/2" PPH SMS	1
12	12725	#6 X 1/2" PPH SMS	2
13	12719A	BODY O-RING	1
14	12754	O-RING SEGMENT	1
15	12720	1/4" - 20 X 2 1/2" SL IND HWHS	10
16	V07018	1/4" LOCK WASHER	10
17	V07019	1/4" - 20 HEX NUT	10
18	12775A	7/16" - 14 HEX NUT	1
19	12902A	3/16" SQ. X 5/8" KEY	2
20	12707W	WET SEAL REAR BRACKET	1
21	12702A	VOLUTE	1
22	12772	5 VANE IMPELLER	1
23	12202W	WET SEAL RESERVOIR	1
24	12766	5/16" - 24 X 3 3/4" HFS	1
25	CV10175	GASKET	1
26	12902A	1/4" SQ. 3/4" KEY STOCK	1
27	UV15163	O-RING FOR DRAIN PLUG	4

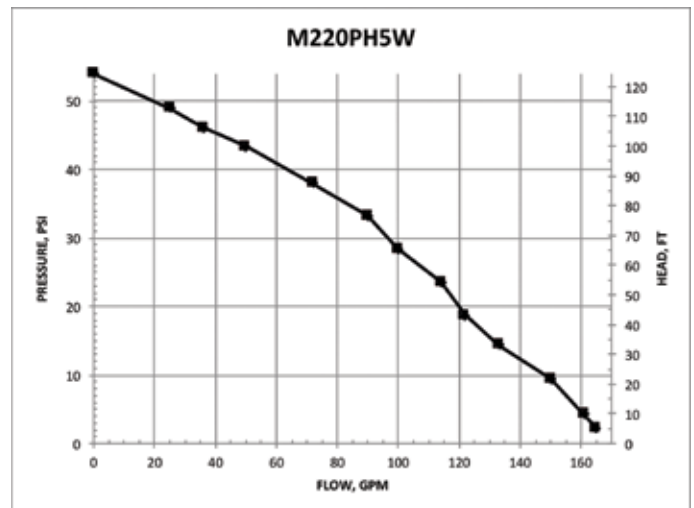

# CENTRIFUGAL PUMPS

## 2" POLYPROPYLENE MANIFOLD WET SEAL PUMPS WITH HYDRAULIC MOTORS

### FEATURES

- Run dry capability
- Double seal contained in ethylene glycol reservoir. Carbon ceramic seal faces with stainless steel cup and spring with EPDM rubber
- Pump end separated from engine
- V-shaped for quicker priming
- See pages 39-45 on manifold fittings for easy plumbing.



### POLY MANIFOLD WET SEAL PUMPS W/HYDRAULIC MOTOR

PART NO	DESCRIPTION	HP	QTY
M220PHYW	2" MANIFOLD POLY WET SEAL PUMP W/ HYDRAULIC MOTOR	12	1

### SPOOL VALVE ASSEMBLY DIAGRAM

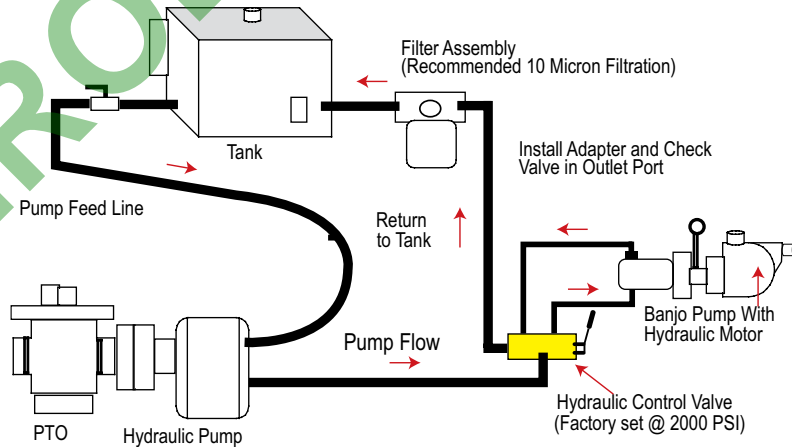

WARNING! DO NOT USE WITH FLAMMABLE LIQUIDS



### HYDRAULIC MOTOR SPOOL VALVE

PART NO	DESCRIPTION	HP	QTY
HSV1000	HYDRAULIC MOTOR SPOOL VALVE	N/A	1

# CENTRIFUGAL PUMPS

2" POLYPROPYLENE  
MANIFOLD WET SEAL PUMPS  
WITH HYDRAULIC MOTORS

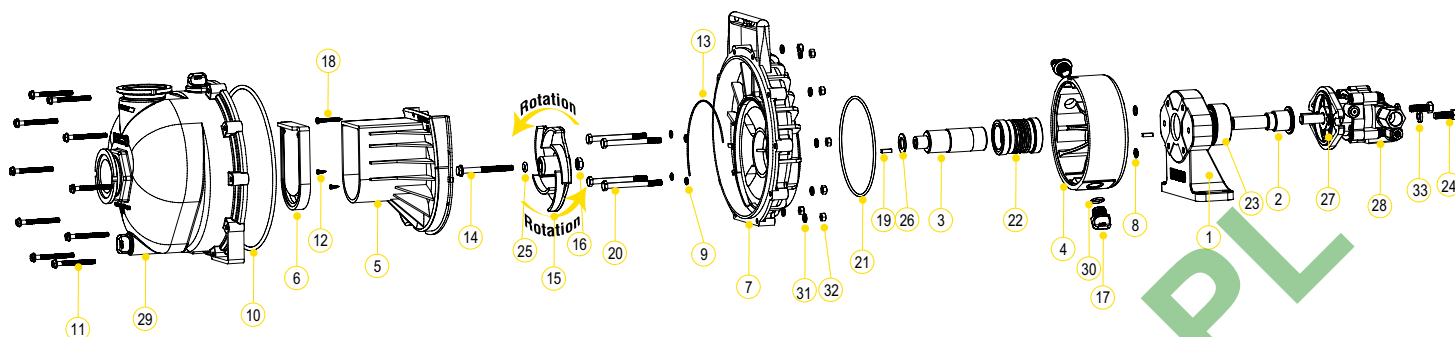

## REPLACEMENT PARTS 2" POLY PUMPS

ITEM	PART NO	DESCRIPTION	QTY
1	12049E	HYDRAULIC PEDESTAL HOUSING	1
2	12055E	HYDRAULIC ADAPTER SHAFT	1
3	12155	ADAPTER SHAFT	1
4	12202W	WET SEAL RESERVOIR	1
5	12702A	VOLUTE	1
6	12705	CHECK VALVE	1
7	12707W	REAR BRACKET	1
8	12709	O-RING	4
9	12717	O-RING FOR SCREW HEADS	4
10	12719A	O-RING	1
11	12720	SS BODY SCREWS	10
12	12725	SS VOLUTE SCREWS	2
13	12754	O-RING SEGMENT	1
14	12766	5/16" - 24 X 3/4" HFS	1
15	12772	IMPELLER	1
16	12775A	IMPELLER HEX NUT	1
17	12777	1/2" PLUG	2
18	12900	SS UPPER VOLUTE SCREW	1
19	12902A	IMPELLER KEY	2
20	13034	5/16" - 24 X 3/4" HHCS	4
21	13719	O-RING	1
22	15035	MECHANICAL SEAL ASSEMBLY	1
23	17056E	BEARING	1
24	18010SS	3/8"-16 X 1.25" HHCS	2
25	A204	O-RING	1
26	CV10175	GASKET	1
27	HY10131	MGG20025BC1D3 GRESEN HYDRAULIC MOTOR	1
28	HY10132	HYDRAULIC CHECK VALVE	1
29	M12712	2" FP MANIFOLD PUMP BODY ASSEMBLY	1
30	UV15163	O-RING	2
31	V07018	SS LOCK WASHERS	10
32	V07019	SS BODY NUTS	10
33	V20018	3/8" LOCK WASHER	2

## HYDRAULIC MOTOR DATA

U.S. GALLONS/REV.	0.0025
CUBIC INCHES/REV.	0.580
LITERS/REV.	0.0097
MAX HYDRAULIC PRESSURE	2000 PSI
MIN HYDRAULIC PRESSURE	200 PSI
INLET PORT	SAE 10 (7/8-14 UNF-2B)
OUTLET PORT	SAE 10 (7/8-14 UNF-2B)
MINIMUM GPM REQUIRED	6 GPM 2400 RPM
MAXIMUM GPM REQUIRED	10 GPM 4000 RPM
IDEAL GPM REQUIRED	9 GPM 3600 RPM

## CONNECTION INFORMATION

INLET	"A" PORT
OUTLET	"B" PORT

SUPPLIED CHECK VALVE IS TO ENSURE PROPER ROTATION OF THE BANJO PUMP. PLACE CHECK VALVE IN OUTLET PORT (MARKED "B") FOR PROPER RIGHT HAND ROTATION.

## SPOOL VALVE INFORMATION

REQUIRED OUTLET FLOW	MIN 6 GPM / MAX 10 GPM
REQUIRED SYSTEM PRESSURE	MIN 600 PSI / MAX 3000 PSI

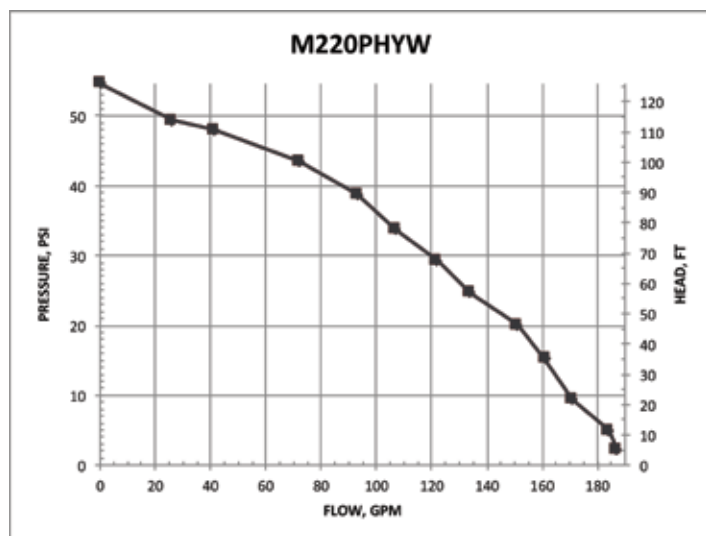

# CENTRIFUGAL PUMPS

## 3" POLY PUMPS

### FEATURES

- Pump end separated from engine
- Large weep holes between pump and engine
- V-shaped for quicker priming
- Pump only comes unassembled

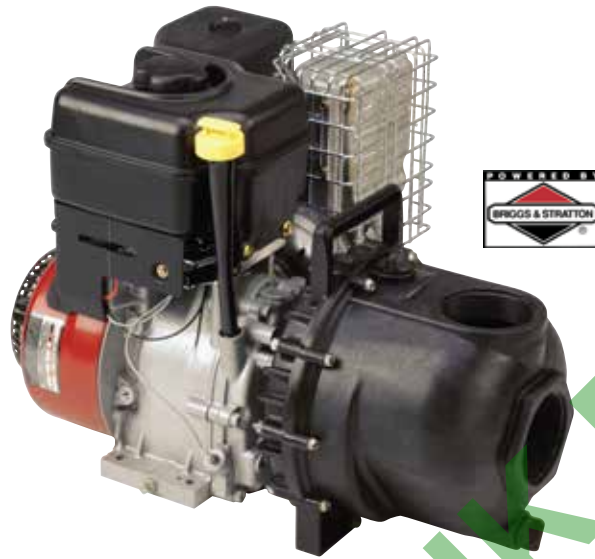

### 3" POLY PUMPS W/GAS ENGINES

PART NO	DESCRIPTION	HP	QTY
300PH-6	3" POLY PUMP W/6.5 HP HONDA® ENGINE	6.5	1
300P11PRO	3" POLY PUMP W/11 HP BRIGGS & STRATTON® ENGINE PRO SERIES W/ELECTRIC START & PULL ROPE	11	1



WARNING! DO NOT RUN PUMP DRY, RESTRICT OR REDUCE PORT SIZES OR DEAD HEAD PUMP



### 3" POLY BEARING PEDESTAL

PART NO	DESCRIPTION	HP	QTY
300PB	3" POLY BEARING PEDESTAL W/ 3/4" SHAFT & 4 VANE IMPELLER	N/A	1



WARNING! DO NOT USE WITH FLAMMABLE LIQUIDS



### 3" POLY PUMP ONLY

PART NO	DESCRIPTION	HP	QTY
300PO	3" POLY PUMP ONLY W/ 3/4" SHAFT & 4 VANE IMPELLER	N/A	1

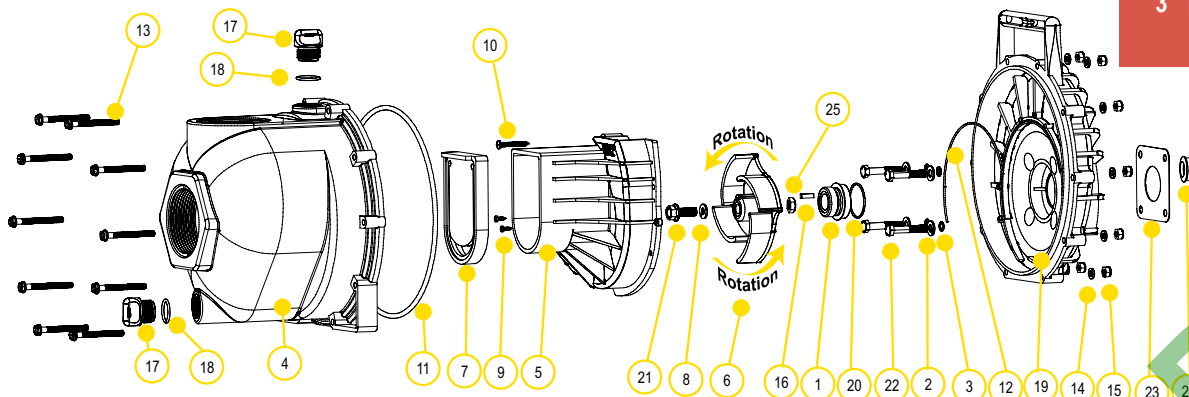

### REPLACEMENT PARTS 3" POLY PUMPS

ITEM	PART NO	DESCRIPTION	QTY
1	12713	SEAL ASSEMBLY	1
2	12901	SS REAR BRACKET WASHER	4
3	12717	O-RING FOR SCREW HEAD	4
4	13712	BODY ASSEMBLY	1
5	13702	POLY PUMP VOLUTE	1
6	13771	4 VANE TRIMMED IMPELLER (300PH-6, 300PB & 300PO)	1
6	13772	4 VANE IMPELLER (300P11PRO)	1
7	12705	CHECK VALVE	1
8	A204	O-RING	1
9	12900	SS UPPER VOLUTE SCREW	4
10	12725	SS VOLUTE SCREWS	2
11	12719A	BODY O-RING	1
12	12754	O-RING SEGMENT	1
13	12720	SS BODY SCREWS	10
14	V07018	SS LOCK WASHERS	10
15	V07019	SS BODY NUTS	10
16	12902A	IMPELLER KEY	1
17	13777	3/4" PLUG	2
18	13778	O-RING	2
19	12703A	POLY PUMP REAR BRACKET	1
20	12710	O-RING FOR SEAL ASSEMBLY	1
21	12765A	SS IMPELLER BOLT 5/16 X 24 X 1.12 (300PH-6)	1
21	13765	SS IMPELLER BOLT 3/8 X 24 X 1.75 (300P11PRO)	1
22	12715A	SS BRACKET SCREWS	4
23	15751	REAR BRACKET SHIM	1
24	12716	POLY PUMP SLINGER	1
25	12775A	IMPELLER HEX NUT	1
N/S	12882A	BEARING PEDESTAL	1
N/S	12099	7/16"-14 X 1.25" HHCS	1
N/S	12000A	POLY PUMP EPDM REPAIR KIT (ITEMS 1, 3, 6-8, 11, 12, 18, 20, 24 & 12099)	1
N/S	13999	PUMP SEAL/O-RING KIT (ITEMS 1, 3, 8, 11, 12, 18, 20, 24 & 12099)	1

### KITS 3" POLY PUMPS

PART NO	EPDM REPAIR KIT NO	EPDM SEAL KIT NO
300PH-6	12000A	13999
300P11PRO	N/A	13999
300PB	12000A	13999
300PO	12000A	13999

SEE 12000A KIT DRAWING ON PAGE 99

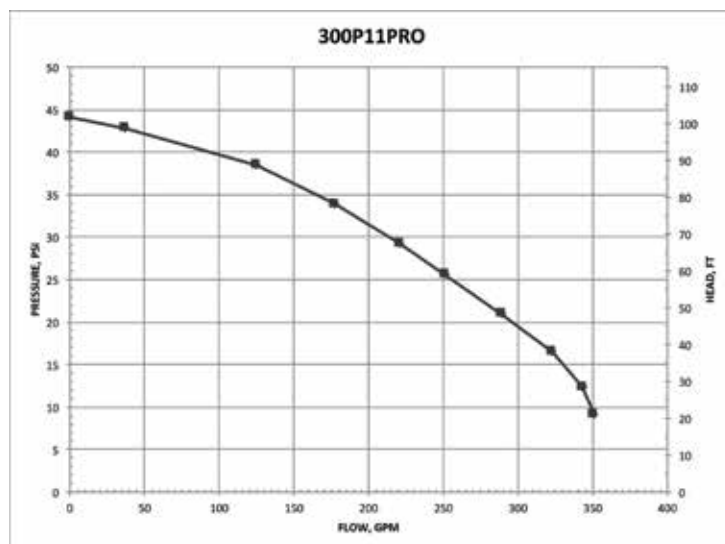

# CENTRIFUGAL PUMPS

## 3" POLY MANIFOLD PUMPS

### FEATURES

- Pump end separated from engine
- Large weep holes between pump and engine
- V-shaped for quicker priming
- Pump only comes unassembled
- See pages 39-45 on manifold fittings for easy plumbing.



### 3" POLY MANIFOLD PUMPS W/GAS ENGINES

PART NO	DESCRIPTION	HP	QTY
M300PH6	3" POLY MANIFOLD PUMP W/6.5 HP HONDA® ENGINE	6.5	1
M300P11PRO	3" POLY MANIFOLD PUMP W/11 HP BRIGGS & STRATTON® PRO SERIES W/ELECTRIC START & PULL ROPE	11	1



WARNING! DO NOT RUN PUMP DRY, RESTRICT OR REDUCE PORT SIZES OR DEAD HEAD PUMP



WARNING! DO NOT USE WITH FLAMMABLE LIQUIDS



### 3" POLY MANIFOLD BEARING PEDESTAL

PART NO	DESCRIPTION	HP	QTY
M300PB	3" POLY MANIFOLD BEARING PEDESTAL W/ 3/4" SHAFT & 4 VANE IMPELLER	N/A	1



### 3" POLY MANIFOLD PUMP ONLY

PART NO	DESCRIPTION	HP	QTY
M300PO	3" POLY MANIFOLD PUMP ONLY W/ 3/4" SHAFT & 4 VANE IMPELLER	N/A	1



# CENTRIFUGAL PUMPS

## 3" POLY MANIFOLD PUMPS

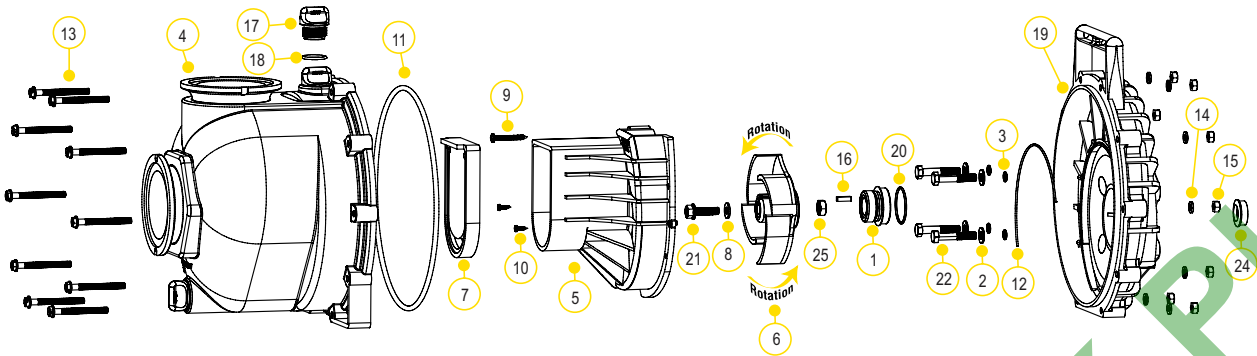

### REPLACEMENT PARTS 3" POLY MANIFOLD PUMPS

ITEM	PART NO	DESCRIPTION	QTY
1	12713	SEAL ASSEMBLY	1
2	12901	SS REAR BRACKET WASHER	4
3	12717	O-RING FOR SCREW HEAD	4
4	M13712	MANIFOLD BODY ASSEMBLY	1
5	13702	POLY PUMP VOLUTE	1
6	13771	4 VANE TRIMMED IMPELLER (M300PH-6, M300PB & M300PO)	1
6	13772	4 VANE IMPELLER (M300P11PRO)	1
7	12705	CHECK VALVE	1
8	A204	O-RING	1
9	12900	SS UPPER VOLUTE SCREW	4
10	12725	SS VOLUTE SCREWS	2
11	12719A	BODY O-RING	1
12	12754	O-RING SEGMENT	10
13	12720	SS BODY SCREWS	10
14	V07018	SS LOCK WASHERS	10
15	V07019	SS BODY NUTS	1
16	12902A	IMPELLER KEY	2
17	13777	3/4" PLUG	2
18	13778	O-RING	1
19	12703A	POLY PUMP REAR BRACKET	1
20	12710	O-RING FOR SEAL ASSEMBLY	1
21	12765A	SS IMPELLER BOLT 5/16 X 24 X 1.12 (-6)	1
21	13765	SS IMPELLER BOLT 3/8 X 24 X 1.75 (M300P11PRO)	1
22	12715A	SS BRACKET SCREWS	4
23	15751	REAR BRACKET SHIM	1
24	12716	POLY PUMP SLINGER	1
25	12775A	IMPELLER HEX NUT	1
N/S	12882A	BEARING PEDESTAL	1
N/S	12099	7/16"-14 X 1.25" HHCS	1
N/S	12000A	POLY PUMP EPDM REPAIR KIT (ITEMS 1, 3, 6-8, 11, 12, 18, 20, 24 & 12099)	1
N/S	13999	PUMP SEAL/O-RING KIT (ITEMS 1, 3, 8, 11, 12, 18, 20, 24 & 12099)	1

### KITS 3" POLY PUMPS

PART NO	EPDM REPAIR KIT NO	EPDM SEAL KIT NO
M300PH6	12000A	13999
M300P6PRO	12000A	13999
M300P11PRO	N/A	13999
M300PB	12000A	13999

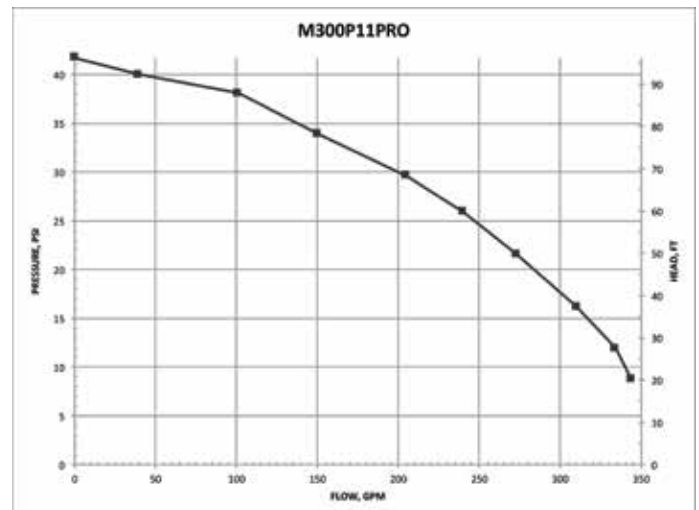

# CENTRIFUGAL PUMPS

## 3" POLY PUMPS WITH HYDRAULIC MOTORS

### FEATURES

- Precision molded construction
- Lightweight
- Corrosion resistant
- Low maintenance
- Hydraulic fluid capacity is minimum 6 gallons and maximum 10 gallons
- Open or closed system
- 3600 R.P.M.
- Recommendation to use the motor spool control valve or a suitable equivalent. The lack of such a valve in this circuit may cause failure to the hydraulic motor.



### 3" POLY PUMPS W/HYDRAULIC MOTORS

PART NO	DESCRIPTION	HP	QTY
300PHY	3" POLY PUMP W/12 HP HYDRAULIC MOTOR	12	1
300PHYW	3" POLY WET SEAL PUMP W/12 HP HYDRAULIC MOTOR	12	1
305PHA	3" POLY PUMP W/5 VANE IMPELLER W/OUT HYDRAULIC MOTOR	N/A	1
305PHAW	3" POLY WET SEAL PUMP W/5 VANE IMPELLER W/OUT HYDRAULIC MOTOR	N/A	1
305PHYWV	3" POLY WET SEAL PUMP W/5 VANE IMPELLER W/ HYDRAULIC MOTOR & FKM SEALS	12	1



**WARNING! DO NOT RUN PUMP DRY, RESTRICT OR REDUCE PORT SIZES OR DEAD HEAD PUMP**



**WARNING! DO NOT USE WITH FLAMMABLE LIQUIDS**

### SPOOL VALVE ASSEMBLY DIAGRAM

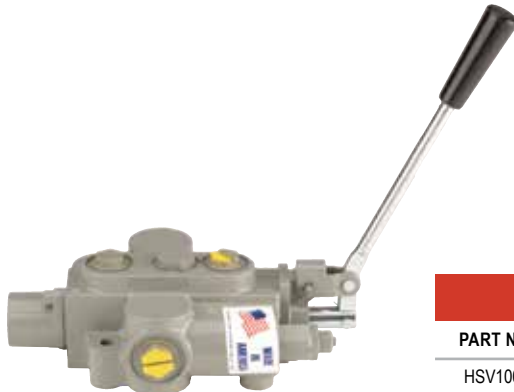
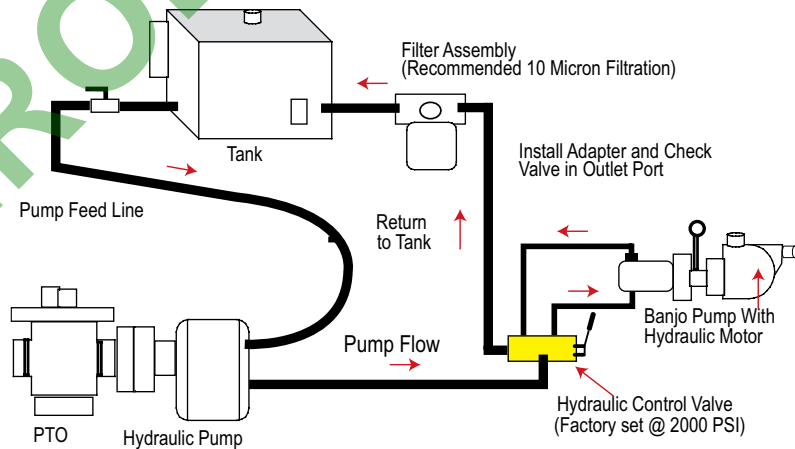

### HYDRAULIC MOTOR SPOOL VALVE

PART NO	DESCRIPTION	HP	QTY
HSV1000	HYDRAULIC MOTOR SPOOL VALVE	N/A	1

# CENTRIFUGAL PUMPS

## 3" POLY PUMPS WITH HYDRAULIC MOTORS

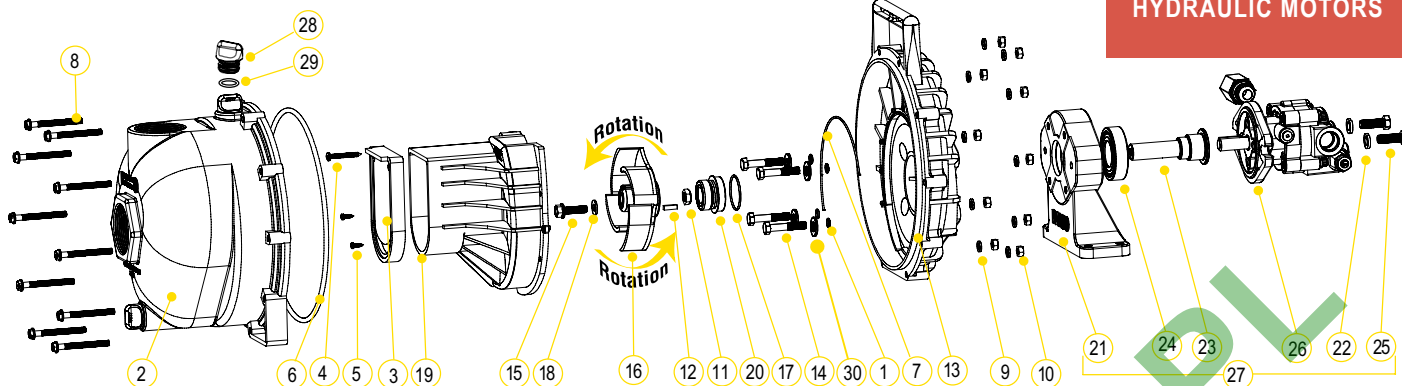

### REPLACEMENT PARTS 3" POLY PUMPS

ITEM	PART NO	DESCRIPTION	QTY
1	12717	O-RING FOR SCREW HEADS	4
2	13712	BODY ASSEMBLY	1
3	12705	CHECK VALVE	1
4	12900	SS UPPER VOLUTE SCREW	4
5	12725	SS VOLUTE SCREWS	2
6	12719A	BODY O-RING	1
7	12754	O-RING SEGMENT	1
8	12720	SS BODY SCREWS	10
9	V07018	SS LOCK WASHERS	10
10	V07019	SS BODY NUTS	10
11	12775A	IMPELLER HEX NUT	1
12	12902A	IMPELLER KEY	1
13	12703A	POLY PUMP REAR BRACKET	1
14	12715A	5/16"-24 X 1.75" HHCS	4
15	12765A	SS IMPELLER BOLT	1
16	13772	TRIMMED 4 VANE IMPELLER	1
17	12710	O-RING FOR SEAL ASSEMBLY	1
18	A204	O-RING	1
19	13702	POLY PUMP VOLUTE	1
20	12713	MECHANICAL SEAL ASSEMBLY	1
21	12049E	HYDRAULIC PEDESTAL HOUSING (MUST ORDER 17056E & 12055E)	1
22	V20018	3/8" LOCK WASHER	2
23	12055E	ADAPTER SHAFT	1
24	17056E	BEARING	1
25	18010SS	3/8" - 16 X 1 1/8" SS CAP SCREW HXHD	2
26	HY1013	HYDRAULIC MOTOR	1
27	12600B	COMPLETE HYDRAULIC ASSEMBLY	1
28	13777	3/4" PLUG	2
29	13778	O-RING	2
30	12901	SS REAR BRACKET WASHER (300PHY)	4
N/S	HY1003	HYDRAULIC MOTOR SEAL KIT	1
KIT	12000A	POLY PUMP EPDM REPAIR KIT (ITEMS 2,4,7-8,16-19, 21, 30, 12099)	1
KIT	13999	PUMP SEAL/O-RING KIT (ITEMS 2,4,7-8,16,18,19, 21, 30, 12099)	1

### KITS 3" POLY PUMPS

PART NO	EPDM REPAIR KIT NO	EPDM SEAL KIT NO	HYDRAULIC MOTOR SEAL KIT
300PHY	12000A	13999	HY1003

### HYDRAULIC MOTOR DATA

U.S. GALLONS/REV.	0.0025
CUBIC INCHES/REV.	0.580
LITERS/REV.	0.0097
MAX HYDRAULIC PRESSURE	2000 PSI
MIN HYDRAULIC PRESSURE	200 PSI
INLET PORT	SAE 10 (7/8-14 UNF-2B)
OUTLET PORT	SAE 10 (7/8-14 UNF-2B)
MINIMUM GPM REQUIRED	6 GPM 2400 RPM
MAXIMUM GPM REQUIRED	10 GPM 4000 RPM
IDEAL GPM REQUIRED	9 GPM 3600 RPM

### CONNECTION INFORMATION

INLET	"A" PORT
OUTLET	"B" PORT
SUPPLIED CHECK VALVE IS TO ENSURE PROPER ROTATION OF THE BANJO PUMP. PLACE CHECK VALVE IN OUTLET PORT (MARKED "B") FOR PROPER RIGHT HAND ROTATION.	

### SPOOL VALVE INFORMATION

REQUIRED OUTLET FLOW	MIN 6 GPM / MAX 10 GPM
REQUIRED SYSTEM PRESSURE	MIN 600 PSI / MAX 3000 PSI

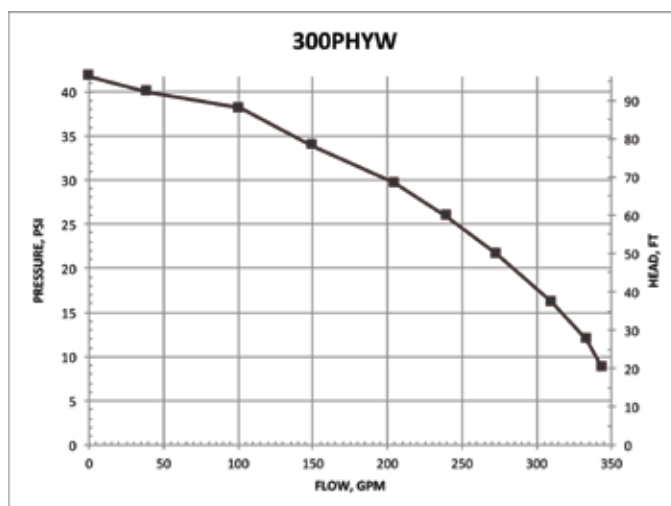

# CENTRIFUGAL PUMPS

## 3" POLY WET SEAL PUMPS

### FEATURES

- Run dry capability
- Double seal contained in ethylene glycol reservoir. Carbon ceramic seal faces with stainless steel cup and spring with EPDM rubber.
- V-shaped for quicker priming
- Engine warranty service available at authorized Briggs & Stratton® and Honda® dealers
- Due to weight and size of pumps, Banjo ships these by truck only.



WARNING! DO NOT USE WITH FLAMMABLE LIQUIDS

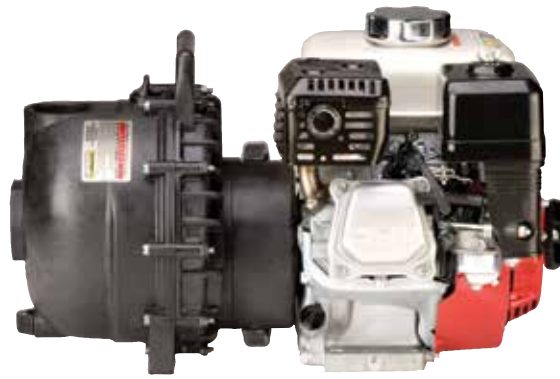

### 3" POLY WET SEAL PUMPS W/GAS ENGINES

PART NO	DESCRIPTION	HP	QTY
300PH6W	3" POLY WET SEAL PUMP W/6 HP HONDA® ENGINE	6	1
300P11PROW	3" POLY WET SEAL PUMP W/11 HP BRIGGS & STRATTON® ENGINE PRO SERIES W/ELECTRIC START & PULL ROPE	11	1
300PH13W	3" POLY WET SEAL PUMP W/13 HP HONDA® ENGINE W/ELECTRIC START & PULL ROPE	13	1



### 3" POLY WET SEAL BEARING PEDESTAL

PART NO	DESCRIPTION	HP	QTY
300PBW	3" POLY WET SEAL BEARING PEDESTAL W/ 3/4" SHAFT & 4 VANE IMPELLER	N/A	1



### 3" POLY WET SEAL PUMP ONLY

PART NO	DESCRIPTION	HP	QTY
300POW	3" POLY WET SEAL PUMP ONLY FOR 1" SHAFT	N/A	1
300POW6	3" POLY WET SEAL PUMP ONLY FOR 3/4" SHAFT	N/A	1

WWW.BANJO.COM/PL

# CENTRIFUGAL PUMPS

## 3" POLY WET SEAL PUMPS

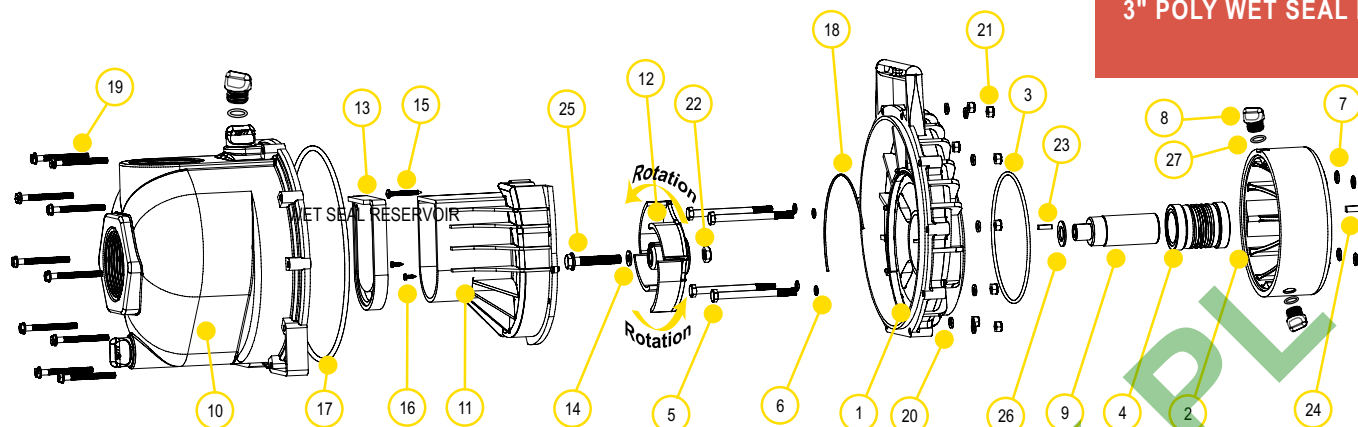

### REPLACEMENT PARTS 3" POLY PUMPS

ITEM	PART NO	DESCRIPTION	QTY
1	12703AW	WET SEAL REAR BRACKET	1
2	12201W	WET SEAL RESERVOIR	1
2	12202W	WET SEAL RESERVOIR (300POW6)	1
3	13719	O-RING	1
3	13719V	FKM O-RING (301POWV)	1
4	15035E	EPDM MECHANICAL SEAL ASSEMBLY	1
4	15035	MECHANICAL SEAL ASSEMBLY (301POWV)	1
5	13034	5/16" - 24 X 3 3/4" HHCS	4
6	12717	O-RING FOR BRACKET SCREW	4
6	12717V	FKM O-RING FOR BRACKET SCREW (301POWV)	4
7	12709	O-RING	4
7	12709V	FKM O-RING (301POWV)	4
8	12777	1/2" PLUG	4
9	13055	ADAPTER SHAFT (300PH6W & 300PH13W)	1
9	N/A	ADAPTER SHAFT (300P11PROW & 301POWV)	1
9	12155	ADAPTER SHAFT (300PH6W)	1
10	13712	BODY ASSEMBLY	1
10	13712	FKM BODY ASSEMBLY (301POWV)	1
11	13702	VOLUTE	1
12	13772	4 VANE IMPELLER	1
12	13771	TRIMMED IMPELLER (300POW6)	1
13	12705	CHECK VALVE	1
13	12705V	FKM CHECK VALVE (301POWV)	1
14	A204	IMPELLER BOLT GASKET	1
14	A204V	FKM IMPELLER BOLT GASKET (301POWV)	1
15	12900	#10 X 1 1/2" PPH SMS	1
16	12725	#6 X 1/2" PPH SMS	2
17	13719	BODY O-RING	1
17	13719V	FKM BODY O-RING (301POWV)	1
18	12754	O-RING SEGMENT	1
18	12754V	FKM O-RING SEGMENT (301POWV)	1
19	12720	1/4" - 20 X 2 1/2" SL IND HWHS	10
20	V07018	1/4" LOCK WASHER	10
21	V07019	1/4" - 20 HEX NUT	10
22	12775A	7/16" - 14 HEX NUT	1
23	12902A	3/16" SQ. X 5/8" KEY	2
24	16901	1/4" SQUARE KEY	1
25	13766	3/8"-24 X 2 1/4" HFS	1

### REPLACEMENT PARTS 3" POLY PUMPS

ITEM	PART NO	DESCRIPTION	QTY
26	CV10175	GASKET	1
26	CV10175V	FKM GASKET (301POWV)	1
27	UV15163	O-RING FOR DRAIN PLUG	4
27	UV15163V	FKM O-RING FOR DRAIN PLUG (301POWV)	4



# CENTRIFUGAL PUMPS

## 3" POLY MANIFOLD WET SEAL PUMPS

### FEATURES

- Run dry capability
- Double seal contained in ethylene glycol reservoir. Carbon ceramic seal faces with stainless steel cup and spring with EPDM rubber
- Pump end separated from engine
- V-shaped for quicker priming
- Engine warranty service available at authorized dealers
- See pages 39-45 on manifold fittings for easy plumbing.



### 3" POLY MANIFOLD WET SEAL PUMPS W/GAS ENGINES

PART NO	DESCRIPTION	HP	QTY
M300PH6W	3" POLY MANIFOLD WET SEAL PUMP W/6 HP HONDA® ENGINE	6	1



### 3" POLY MANIFOLD WET SEAL BEARING PEDESTAL

PART NO	DESCRIPTION	HP	QTY
M300PBW	3" POLY MANIFOLD WET SEAL BEARING PEDESTAL W/ 1/4" SHAFT & 4 VANE IMPELLER	N/A	1



### 3" POLY MANIFOLD WET SEAL PUMP ONLYS

PART NO	DESCRIPTION	HP	QTY
M300POW	3" POLY MANIFOLD WET SEAL PUMP ONLY	N/A	1



### 3" POLY MANIFOLD WET SEAL PUMP W/HYDRAULIC

PART NO	DESCRIPTION	HP	QTY
M305PHYW	3" POLY MANIFOLD WET SEAL PUMP W/HYDRAULIC MOTOR	N/A	1



WARNING! DO NOT USE WITH FLAMMABLE LIQUIDS

# CENTRIFUGAL PUMPS

3" POLY MANIFOLD WET SEAL PUMPS

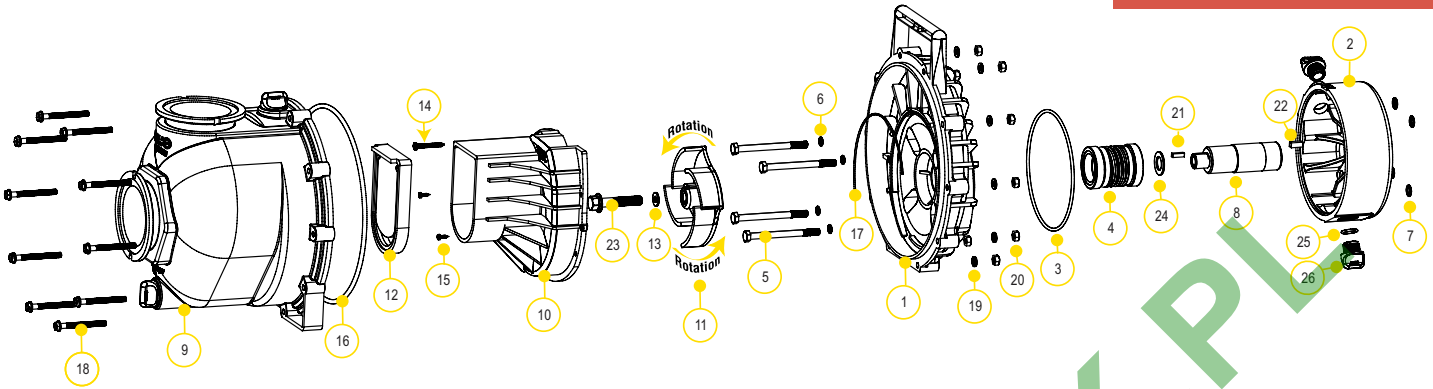

## REPLACEMENT PARTS 3" POLY PUMPS

ITEM	PART NO	DESCRIPTION	QTY
1	12707W	WET SEAL REAR BRACKET FOR 6 HP HONDA® ENGINE & BEARING PEDESTAL	1
2	12202W	WET SEAL RESERVOIR FOR 6 HP HONDA® ENGINE & BEARING PEDESTAL	1
3	13719	O-RING	1
4	15035E	MECHANICAL SEAL ASSEMBLY EPDM	1
5	13034	5/16" - 24 X 3 3/4" HHCS	4
6	12717	O-RING FOR BRACKET SCREW	4
7	12709	O-RING	4
8	12155	ADAPTER SHAFT FOR 6 HP HONDA® ENGINE & BEARING PEDESTAL	1
9	M13712	MANIFOLD BODY ASSEMBLY	1
10	13702	VOLUTE	1
11	13772	4 VANE IMPELLER	1
12	12705	CHECK VALVE	1
13	A204	O-RING	1
14	12900	#10 X 1 1/2" PPH SMS 18-8 SS	1
15	12725	#6 X 1 1/2" PPH SMS 18-8 SS	1
16	12719A	BODY O-RING	1
17	12754	O-RING SEGMENT	1
18	12720	1/4" - 20 X 2 1/2" SL IND HWHS	10
19	V07018	1/4" LOCK WASHER	10
20	V07019	1/4" - 20 HEX NUT	10
21	12902A	3/16" SQ. X 5/8" KEY	1
22	16901	1/4" SQ. 3/4" KEY STOCK	1
23	12766	5/16"-24 X 3 3/4" HFS FOR 6 HP HONDA® ENGINE & BEARING PEDESTAL	1
24	CV10175	GASKET	1
25	UV15163	O-RING	2
26	12777	1/2" PLUG	2

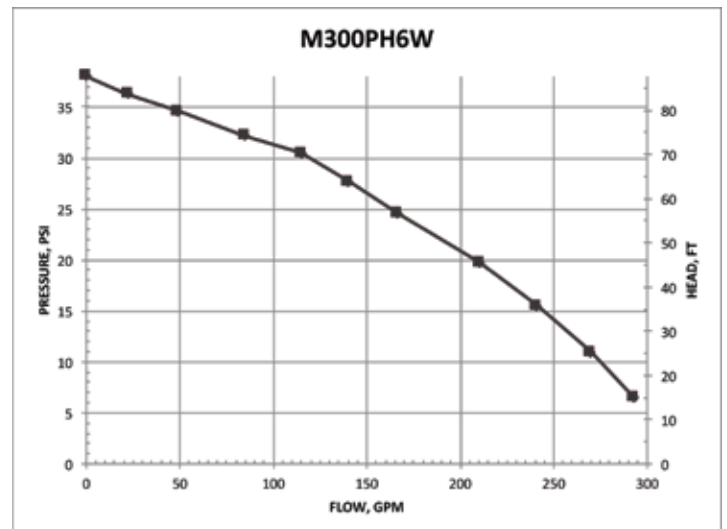

# CENTRIFUGAL PUMPS

## 1½" - 2" CAST IRON PUMPS

### FEATURES

- Cast iron construction for rugged dependable service
- Stainless steel shaft sleeve to protect engine shaft
- Carbon ceramic seal with stainless steel cup and spring with FKM rubber
- Replaceable inlet and outlet flanges
- Dynamically balanced impeller
- Pump only packs complete and ready for attachment to gasoline engine
- Pedestal pump for long coupling to electric motor
- Recommendation for 5/8" shaft: 56C frame size, 3 HP, 3450 RPM & 5" max impeller for close coupling to electric motors
- Recommendation for 7/8" shaft: 145TC frame size, 3 HP, 3450 RPM & 5" max impeller for close coupling to electric motors
- Engine warranty service available at authorized dealers



WARNING! DO NOT RUN PUMP DRY, RESTRICT OR REDUCE PORT SIZES OR DEAD HEAD PUMP



WARNING! DO NOT USE WITH FLAMMABLE LIQUIDS



### 2" CAST IRON PUMP W/GAS ENGINES

PART NO	DESCRIPTION	HP	QTY
200PI-3	2" CAST IRON PUMP W/3.5 HP BRIGGS & STRATTON® ENGINE	3.5	1
200PI6PRO	2" CAST IRON PUMP W/6.5 HP BRIGGS & STRATTON® ENGINE PRO SERIES	6.5	1
200PIH-5	2" CAST IRON PUMP W/5.5 HP HONDA® ENGINE	5.5	1
200PIH5E	2" CAST IRON PUMP W/5.5 HP HONDA® ENGINE W/ ELECTRIC START	5.5	1

### 2" CAST IRON PUMP ONLY

PART NO	DESCRIPTION	HP	QTY
200POI	2" CAST IRON PUMP ONLY W/ ¾" SHAFT SLEEVE	N/A	1

### 1½" CAST IRON C-FLANGE PUMPS

PART NO	DESCRIPTION	HP	QTY
150POICF5/8-4.1	1½" CAST IRON C-FLANGE PUMP W/ 5/8" SHAFT SLEEVE & 4.1 IMPELLER	N/A	1

### 2" CAST IRON C-FLANGE PUMPS

PART NO	DESCRIPTION	HP	QTY
200POICF5/8	2" CAST IRON C-FLANGE PUMP W/ 5/8" SHAFT SLEEVE	N/A	1

### 2" CAST IRON BEARING PEDESTAL

PART NO	DESCRIPTION	HP	QTY
200PBI	2" CAST IRON BEARING PEDESTAL W/ ¾" STRAIGHT SHAFT	N/A	1



# CENTRIFUGAL PUMPS

1½" - 2" CAST IRON PUMPS

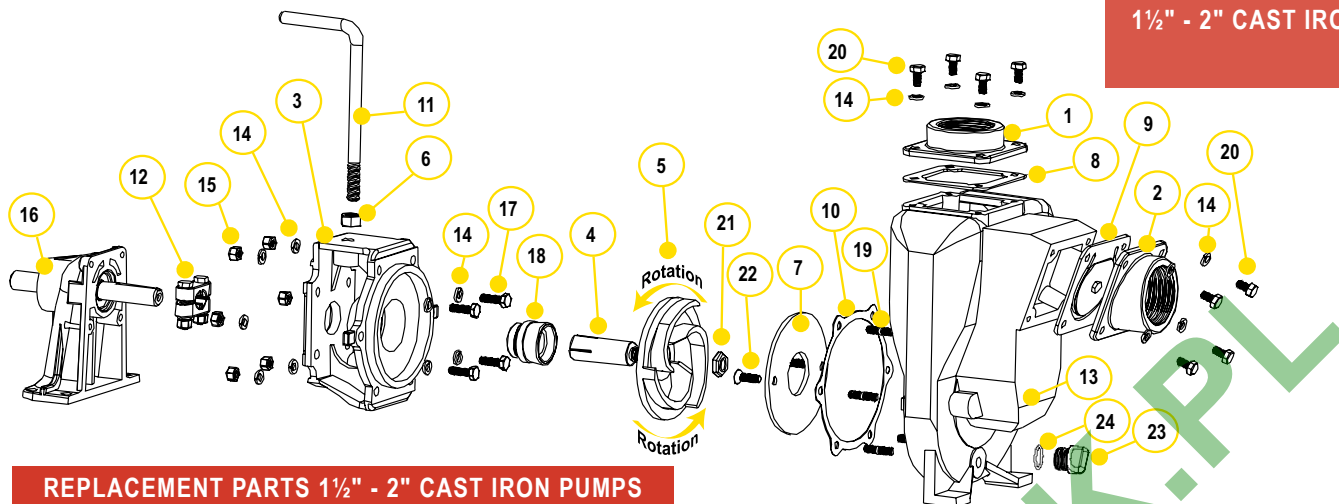

## REPLACEMENT PARTS 1½" - 2" CAST IRON PUMPS

ITEM	PART NO	DESCRIPTION	QTY
1	17001	1½" NPT OUTLET FLANGE	1
1	17000	2" NPT OUTLET FLANGE	1
2	17003	1½" NPT INLET FLANGE	1
2	17002	2" NPT INLET FLANGE	1
3	17004	ADAPTER FOR GAS ENGINE	1
3	17046	C-FACE ADAPTER	1
4	17005	5/8" SLEEVE DRIVE FOR ELECTRIC MOTOR	1
4*	17006	¾" SLEEVE DRIVE	1
4	17007	7/8" SLEEVE DRIVE FOR ELECTRIC MOTOR	1
5*	17008	5" IMPELLER	1
5	17008-4.1	4.1" TRIMMED IMPELLER	1
6	17010	½" HEX NUT	1
7*	17011	WEAR PLATE	1
8	17013	EPDM GASKET	1
9	17016	CHECK VALVE ASSEMBLY	1
10*	17018	GASKET ADAPTER	1
11	15022	HANDLE	1
12	17023	5/8" CLAMP FOR ¾" SHAFT ASSEMBLY (OLD STYLE)	1
12	17123	5/8" CLAMP FOR ¾" SHAFT ASSEMBLY (KEYED)	1
12	17024	7/8" CLAMP FOR SHAFT ASSEMBLY	1
13	17026	PUMP HOUSING	1
14	V10118	5/16" LOCK WASHER	18
15	V10119	5/16" - 18 SS HEX NUT	6
N/S	12883B	BEARINGS	1
16	12882A	COMPLETE PEDESTAL ASSEMBLY	2
17	17040	5/16" -24 X 1.00" CAP SCREW	1
18	17028	EPDM SEAL ASSEMBLY	4
18*	17035	FKM SEAL ASSEMBLY	1
18	17035SD	SEVERE DUTY SEAL	1
19	17042	STUD	6
20	17019	5/16"-18 X ¾" CAP SCREW	8
21	17009B	5/8" IMPELLER NUT	1
22	17130	5/16-18 X 1.00" FHSCS, 18-8 SS	2
23	12777	½" PLUG	1
24	UV15163	O-RING	1
N/S	17033	Z RAILS (PAIR)	1
N/S	17100	REPAIR KIT (CONSISTS OF ITEMS 4*, 5*, 7,10,18*)	1

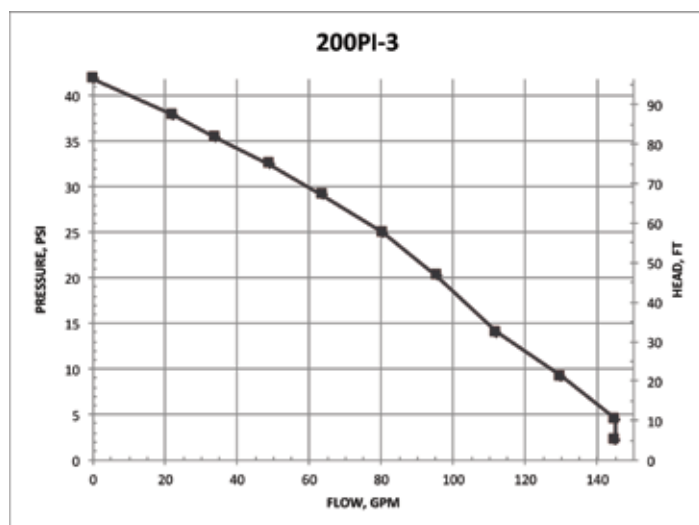

# CENTRIFUGAL PUMPS

## 2" CAST IRON WET SEAL PUMPS

### FEATURES

- Cast iron construction for rugged dependable service
- Stainless steel hardware
- FKM double seal contained in glycol reservoir
- Replaceable inlet and outlet flanges
- Dynamically balanced impeller
- Pump only packs complete and ready for attachment to gasoline engine
- Pedestal pump for long coupling to electric motor
- Due to weight and size of pumps, Banjo ships these by truck only.



### 2" CAST IRON WET SEAL PUMPS W/GAS ENGINES

PART NO	DESCRIPTION	HP	QTY
201PIH5W	2" CAST IRON WET SEAL PUMP W/5.5 HP HONDA® ENGINE	5.5	1



### 2" CAST IRON WET SEAL PUMP ONLY

PART NO	DESCRIPTION	HP	QTY
201POIW	2" CAST IRON WET SEAL PUMP ONLY	N/A	1



WARNING! DO NOT RUN PUMP DRY, RESTRICT OR REDUCE PORT SIZES OR DEAD HEAD PUMP



WARNING! DO NOT USE WITH FLAMMABLE LIQUIDS



### 2" CAST IRON WET SEAL PUMP BEARING PEDESTAL

PART NO	DESCRIPTION	HP	QTY
201PBIW	2" CAST IRON WET SEAL PUMP WITH BEARING PEDESTAL	N/A	1

# CENTRIFUGAL PUMPS

## 2" CAST IRON WET SEAL PUMPS

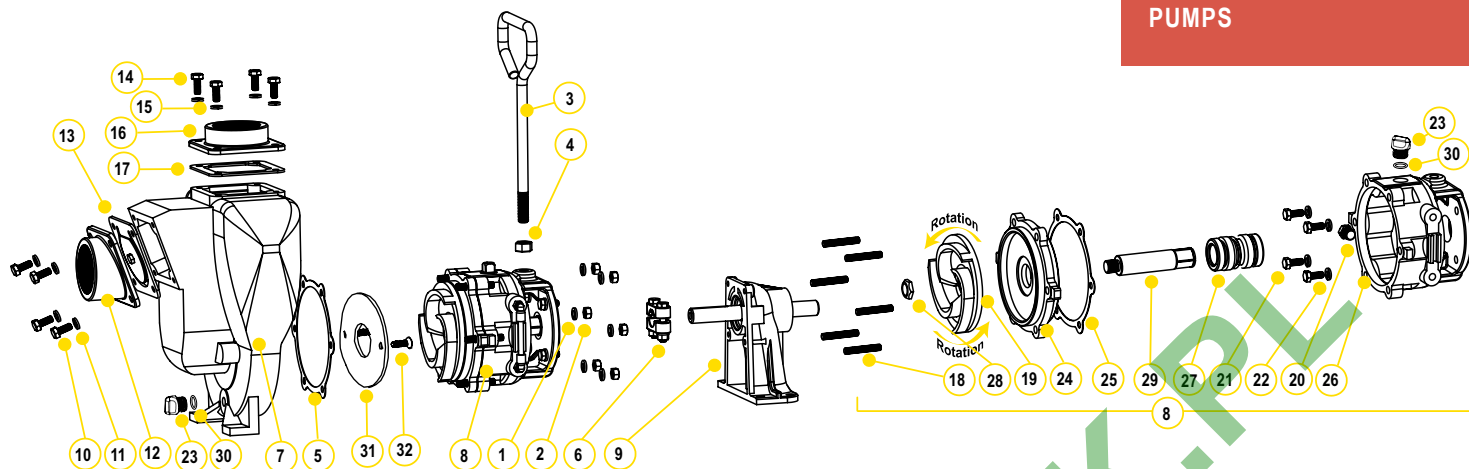

### REPLACEMENT PARTS 2" CAST IRON PUMPS

ITEM	PART NO	DESCRIPTION	QTY
1	V10118	5/16" LOCK WASHER	6
2	V10119	5/16" -18 HEX NUT	6
3	15022	HANDLE	1
4	17010	1/2" HEX NUT	1
5	17018	GASKET ADAPTER	1
6	17123	5/8" CLAMP, 3/4" SHAFT ASSEMBLY KEYED	1
7	17226	PUMP HOUSING	1
8	N/A	WET SEAL ASSEMBLY	1
9	12882A	BEARING PEDESTAL	1
10	17019	5/16"-18 X 3/4" HHCS	4
11	V10118	5/16" LOCK WASHER	4
12	17002	2" NPT INLET FLANGE	1
13	17016	EPDM CHECK VALVE GASKET ASSEMBLY	1
14	17019	5/16" -18 X 3/4" HHCS	4
15	V10118	5/16" LOCK WASHER	4
16	17000	2" NPT OUTLET FLANGE	1
17	17013	EPDM OUTLET GASKET	1
18	17242	HOUSING STUD	6
19	17208	IMPELLER	1
20	17032	PIPE PLUG	1
21	17019	5/16"-18 X 3/4" CAP SCREW	4
22	V10118	5/16" LOCK WASHER	4
23	12777	1/2" PLUG	2
24	17202	COVER PLATE	1
25	17018	GASKET ADAPTER	1
26	17201A	RESERVOIR	1
27	17235	FKM MECHANICAL SEAL ASSEMBLY	1
28	17009B	5/8" IMPELLER NUT	1
29	17206A	ADAPTER SHAFT	1
30	UV15163	O-RING	2
31	17011	Wear Plate	1
32	17130	5/16-18 X 1.00" FHSCS, 18-8 SS	1

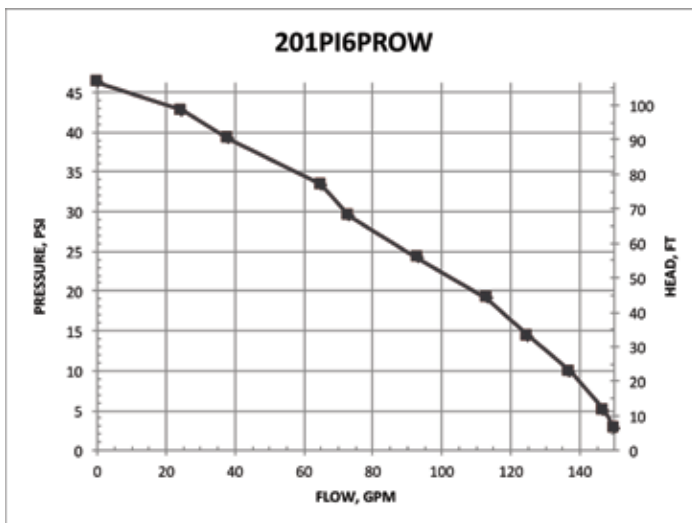

# CENTRIFUGAL PUMPS

## 2" CAST IRON PUMPS WITH ELECTRIC MOTORS

### FEATURES

- Cast iron construction for rugged dependable service
- Stainless steel shaft sleeve to protect engine shaft
- Carbon ceramic seal with stainless steel cup and spring with FKM rubber
- Replaceable inlet and outlet flanges
- Dynamically balanced impeller
- Pump only packs complete and ready for attachment to gasoline engine
- Due to weight and size of pumps, Banjo ships these by truck only.
- Motor warranty service available at authorized dealers
- Motor features include pressure cast aluminum end plates with ribbed design for rigidity, heavy gauge steel frame, 230 volt, with inverter spike resistance magnet wire



### 2" CAST IRON PUMPS W/ELECTRIC MOTORS

PART NO	DESCRIPTION	HP	QTY
234PIE5	2" CAST IRON PUMP W/5 HP THREE PHASE ELECTRIC MOTOR	5	1
234PIE51	2" CAST IRON PUMP W/5 HP SINGLE PHASE ELECTRIC MOTOR	5	1

### 2" CAST IRON PUMP ONLY

PART NO	DESCRIPTION	HP	QTY
234POI	2" CAST IRON PUMP ONLY W 184TC FRAME ADAPTER	N/A	1



WARNING! DO NOT RUN PUMP DRY, RESTRICT OR REDUCE PORT SIZES OR DEAD HEAD PUMP



WARNING! DO NOT USE WITH FLAMMABLE LIQUIDS

# CENTRIFUGAL PUMPS

2" CAST IRON PUMPS WITH ELECTRIC MOTORS

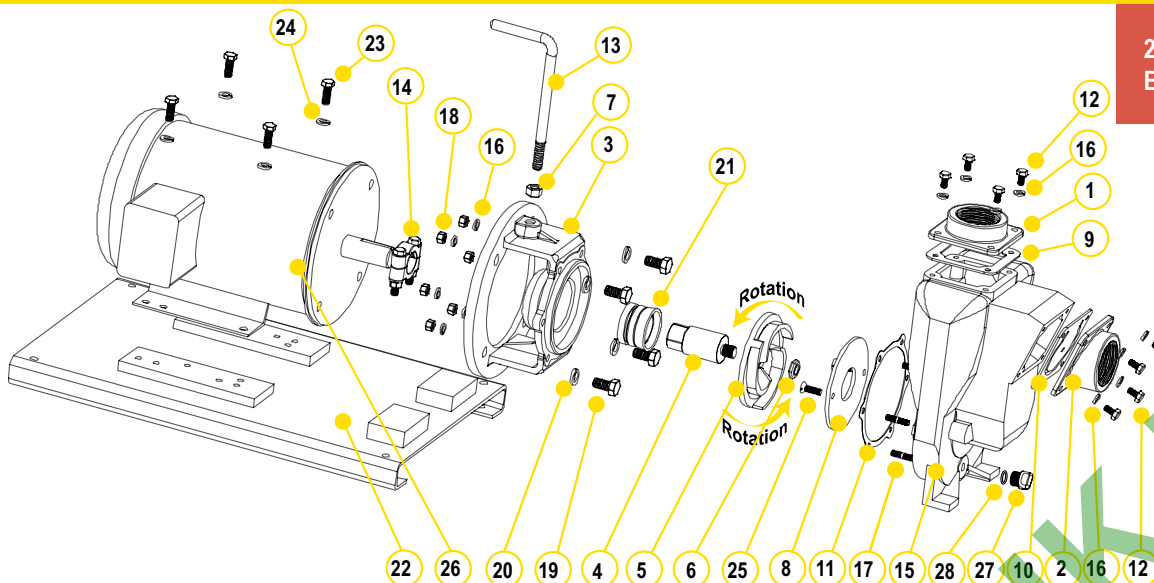

## REPLACEMENT PARTS 2" CAST IRON PUMPS

ITEM	PART NO	DESCRIPTION	QTY
1	17000	2" NPT OUTLET FLANGE	1
2	17002	2" NPT INLET FLANGE	1
3	17046	C-FACE ADAPTER (234PIE3)	1
3	17446	C-FACE ADAPTER	1
4	17007	IMPELLER SHAFT (234PIE3)	1
4	17406	IMPELLER SHAFT	1
5	17008	IMPELLER (234PIE3)	1
5	17408	IMPELLER	1
6	17009B	5/8" IMPELLER NUT	1
7	17010	1/2" HEX NUT	1
8	17011	WEAR PLATE	1
9	17013	OUTLET GASKET	1
10	17016	GASKET & CHECK VALVE	1
11	17018	GASKET ADAPTER	1
12	17019	BOLT	8
13	15022	HANDLE	1
14	17024	CLAMP ASSEMBLY W/KEY (234PIE3)	1
14	18129	CLAMP ASSEMBLY W/KEY	1
15	17026	PUMP HOUSING	1
16	V10118	5/16" LOCK WASHER	20
17	17042	HOUSING STUD	6
18	V10119	HEX NUT	8
19	N/A	BOLT	4
20	N/A	WASHER	4
21	17035	SEAL ASSEMBLY (234PIE3)	1
21	18025	SEAL ASSEMBLY	1
22	17701	BASE PLATE ASSEMBLY	1
23	17704	BOLT	4
24	V20018	3/8" LOCK WASHER	4
25	17130	5/16-18 X 1.00" FHSCS, 18-8 SS	2
26	N/A	ELECTRIC MOTOR	1
27	12777	1/2" PLUG	1
28	UV15163	O-RING FOR DRAIN PLUG	1

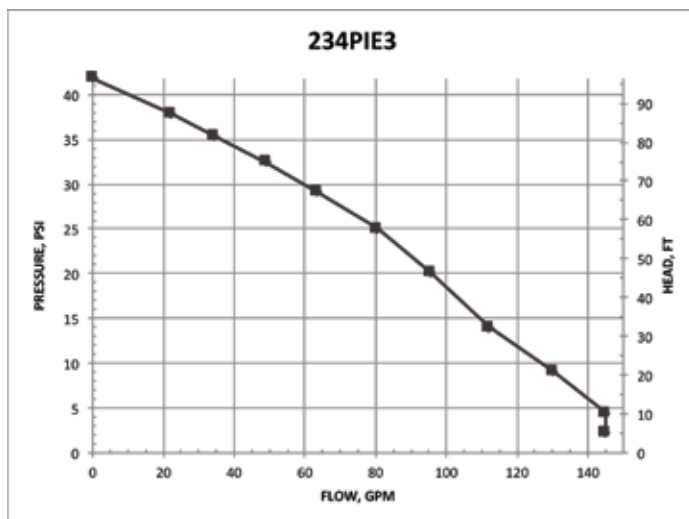

# CENTRIFUGAL PUMPS

## 2" CAST IRON PUMPS WITH HYDRAULIC MOTORS

### FEATURES

- Cast iron construction for rugged dependable service
- Stainless steel hardware
- Replaceable inlet and outlet flanges
- Dynamically balanced impeller
- Hydraulic fluid capacity is minimum 6 gallons and maximum 10 gallons
- Open or closed system
- 12 HP motor
- Recommendation to use the motor spool control valve or a suitable equivalent. The lack of such a valve in this circuit may cause failure to the hydraulic motor.



### 2" CAST IRON PUMPS WITH HYDRAULIC MOTOR

PART NO	DESCRIPTION	HP	QTY
200PIHY	2" CAST IRON PUMP ONLY WITH HYDRAULIC MOTOR	12	1

### SPOOL VALVE ASSEMBLY DIAGRAM

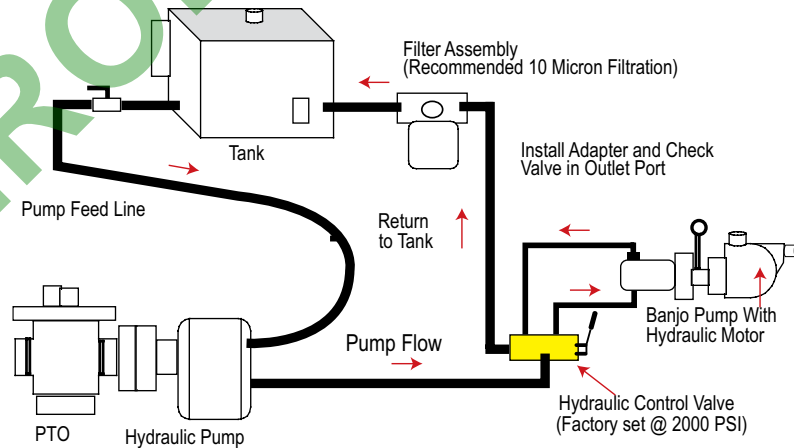

WARNING! DO NOT RUN PUMP DRY, RESTRICT OR REDUCE PORT SIZES OR DEAD HEAD PUMP



WARNING! DO NOT USE WITH FLAMMABLE LIQUIDS



### HYDRAULIC MOTOR SPOOL VALVE

PART NO	DESCRIPTION	HP	QTY
HSV1000	HYDRAULIC MOTOR SPOOL VALVE	N/A	1

# CENTRIFUGAL PUMPS

2" CAST IRON PUMPS WITH HYDRAULIC MOTORS

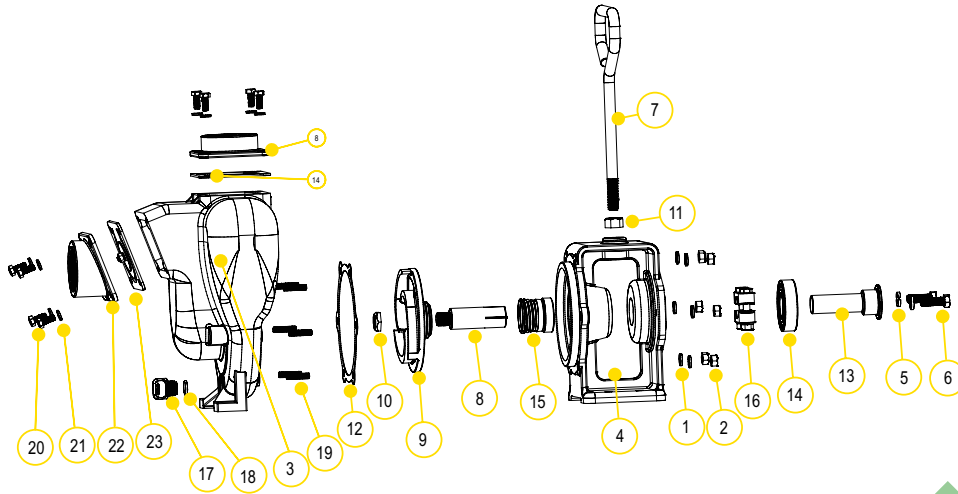

## REPLACEMENT PARTS 2" CAST IRON PUMPS

ITEM	PART NO	DESCRIPTION	QTY
1	V10118	5/16" SPLIT LOCK WASHER	6
2	V10119	5/16"-18 HEX NUT	6
3	17026	PUMP HOUSING	1
4	N/A	HYDRAULIC ADAPTER	1
5	V20018	3/8" LOCK WASHER	2
6	18010SS	3/8"-16 X 1.25" HHCS	2
7	15022	HANDLE	1
8	17007	7/8" SLEEVE DRIVE FOR HYDRAULIC MOTOR	1
9	17008	5" IMPELLER	1
10	17009B	5/8" IMPELLER NUT	1
11	17010	1/2" HEX NUT - 13UNF-RH	1
12	17018	GASKET ADAPTER	1
13	17055A	HYDRAULIC ADAPTER SHAFT	1
14	17056	SKF 6206-2RS1 BEARING	1
15	17035	FKM SEAL ASSEMBLY	1
16	17024	7/8" CLAMP, NO KEY	1
17	12777	1/2" PLUG	1
18	UV15163	O-RING	1

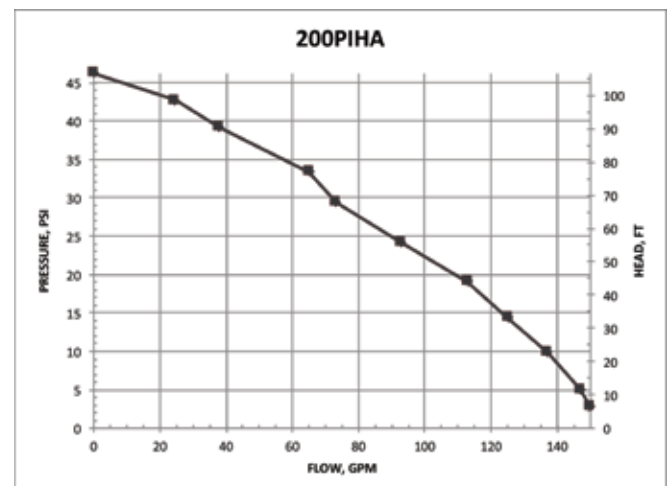

# CENTRIFUGAL PUMPS

## 2" 222 SERIES CAST IRON PUMPS

### FEATURES

- Cast iron construction for rugged dependable service
- Carbon ceramic seal with stainless steel cup and spring with FKM rubber
- Replaceable inlet and outlet flanges
- Dynamically balanced impeller
- Heavy duty slinger seal on motor shaft
- Large weep holes between pump end and engine
- Pump only packs complete and ready for attachment to gasoline engine
- Pedestal pump for long coupling to electric motor
- Recommendation for 3/4" shaft: 5 HP, 3600 RPM
- Due to weight and size of pumps, Banjo ships these by truck only.
- Engine warranty service available at authorized dealers



POWERED by  
**HONDA**

### 222 SERIES CAST IRON PUMPS W/GAS ENGINES

PART NO	DESCRIPTION	HP	QTY
222PIH5	2" CAST IRON PUMP W/5.5 HP HONDA® ENGINE	5.5	1
222PIH6	2" CAST IRON PUMP W/6.5 HP HONDA® ENGINE	6.5	1
222PIH5E	2" CAST IRON PUMP W/5.5 HP HONDA® ENGINE W/ ELECTRIC START	5.5	1
222PI6PRO	2" CAST IRON PUMP W/6.5 HP BRIGGS & STRATTON® ENGINE PRO SERIES	6.5	1



### 222 SERIES CAST IRON PUMP ONLYS

PART NO	DESCRIPTION	HP	QTY
222POI	2" CAST IRON PUMP ONLY W/ FULL IMPELLER	N/A	1



### 222 SERIES CAST IRON BEARING PEDESTAL

PART NO	DESCRIPTION	HP	QTY
222PBI	2" CAST IRON BEARING PEDESTAL W/ 3/4" STRAIGHT KEYED SHAFT	N/A	1



WARNING! DO NOT RUN PUMP DRY, RESTRICT OR REDUCE PORT SIZES OR DEAD HEAD PUMP



WARNING! DO NOT USE WITH FLAMMABLE LIQUIDS



# CENTRIFUGAL PUMPS

## 2" 222 SERIES CAST IRON PUMPS

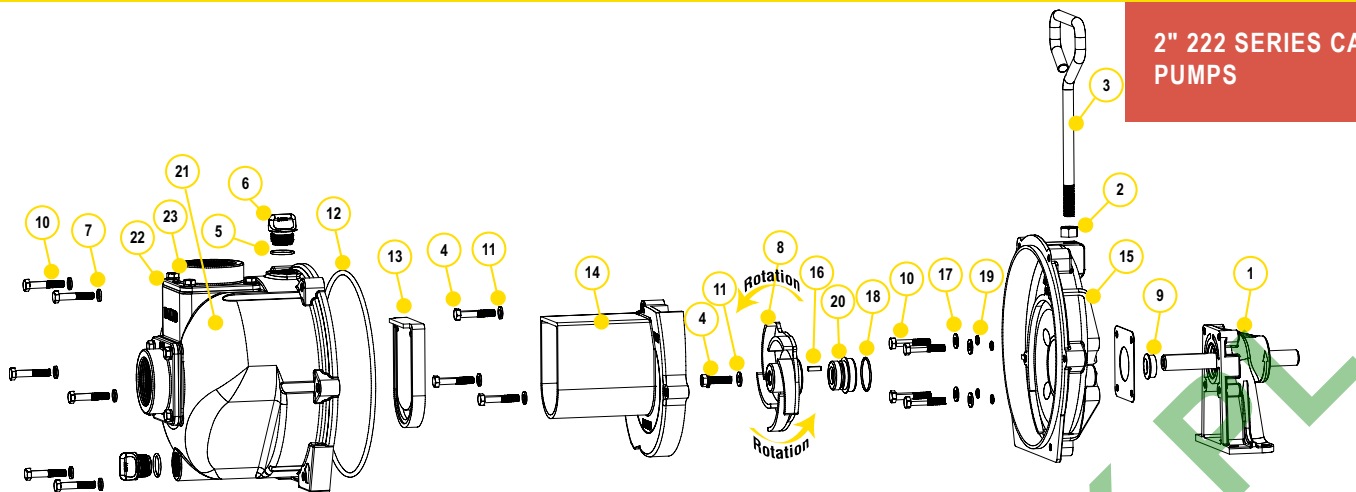

### REPLACEMENT PARTS 2" CAST IRON PUMPS

ITEM	PART NO	DESCRIPTION	QTY
1	12882A	BEARING PEDESTAL ASSEMBLY	1
1	12600B	HYDRAULIC PEDESTAL ASSEMBLY	1
2	17010	1/2" JAM NUT	1
3	15022	HANDLE	1
4	12765A	5/16" - 24 X 1.12 IMPELLER BOLT	1
5	13778	O-RING	2
6	13777	3/4" PLUG	2
7	V10118	5/16" LOCK WASHER	9
8	15772	5 VANE IMPELLER	1
9	12716	PUMP SLINGER	1
10	12715A	5/16" - 24 X 1.75 HHCS	13
11	A204	O-RING	1
12	12719A	BODY O-RING	1
13	12705	CHECK VALVE	1
14	15702	VOLUTE	1
15	15703	REAR BRACKET	1
16	12902A	3/16" SQ X 5/8" KEY	1
17	12901	5/16" FLAT WASHER	4
18	12710	O-RING	1
19	12717	O-RING	4
20	12713V	SEAL ASSEMBLY	1
20	N/A	SEVERE DUTY SEAL	1
21	15712	BODY	1
22	17013	FLANGE GASKET	2
23	17000	2" NPT THREADED FLANGE	2
24	17019	5/16" - 18 X 0.75 HHCS	8
25	V10118	5/16" LOCK WASHER	8
N/S	12099	7/16" - 14 X 1.25" HHCS	1
N/S	15751	BRACKET SHIM	1
N/S	15752	IMPELLER SHIM	1
N/S	17033	Z-RAILS	1 PAIR
N/S	N/A	5/16" - 18 X 1 3/4" ZINC PLATED	4
N/S	V10119	5/16" - 18 HEX NUT	4
N/S	V10118	5/16" LOCK WASHER	4
N/S	15000	REPAIR KIT (ITEMS 5, 8, 11-12, 18-20, 12099, 15751 & 15752)	1
N/S	15000V	FKM REPAIR KIT	1
N/S	15999	SEAL KIT (ITEMS 5, 11-12, 18-20, 12099, 15751 & 15752)	1
N/S	15999V	FKM SEAL KIT	1

### KITS 222 CAST IRON PUMPS

PART NO	EPDM REPAIR KIT NO	FKM REPAIR KIT NO	EPDM SEAL KIT NO	FKM SEAL KIT NO
222PIH5	15000	15000V	15999	15999V
222PIH6	15000	15000V	15999	15999V
222PIH5E	15000	15000V	15999	15999V
222PI6PRO	15000	15000V	15999	15999V
222POI	15000	15000V	15999	15999V
225POI	15000	15000V	15999	15999V
222PBI	15000	15000V	15999	15999V
222PIHY	15000	15000V	15999	15999V

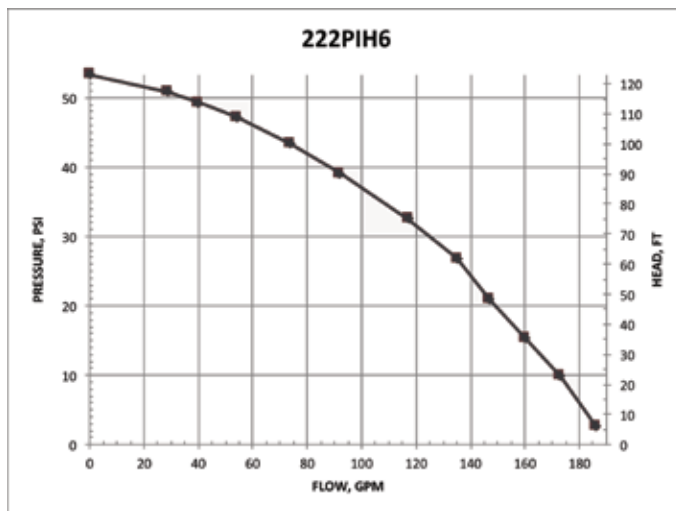

# CENTRIFUGAL PUMPS

## 2" 222 SERIES CAST IRON PUMPS WITH ELECTRIC MOTORS

### FEATURES

- Cast iron construction for rugged dependable service
- Carbon ceramic seal with stainless steel cup and spring with FKM rubber
- Replaceable inlet and outlet flanges
- Dynamically balanced impeller
- Heavy duty slinger seal on motor shaft
- Large weep holes between pump end and engine
- Motor features include pressure cast aluminum end plates with ribbed design for rigidity, heavy gauge steel frame, 230 volt, with inverter spike resistance magnet wire
- Due to weight and size of pumps, Banjo ships these by truck only.



### 222 SERIES CAST IRON PUMPS W/ELECTRIC MOTORS

PART NO	DESCRIPTION	HP	QTY
222PIE5	2" CAST IRON PUMP W/5 HP THREE PHASE ELECTRIC MOTOR	5	1
222PIE1	2" CAST IRON PUMP W/5 HP SINGLE PHASE ELECTRIC MOTOR	5	1



WARNING! DO NOT RUN PUMP DRY, RESTRICT OR REDUCE PORT SIZES OR DEAD HEAD PUMP



WARNING! DO NOT USE WITH FLAMMABLE LIQUIDS

# CENTRIFUGAL PUMPS

2" 222 SERIES CAST IRON PUMPS WITH ELECTRIC MOTORS

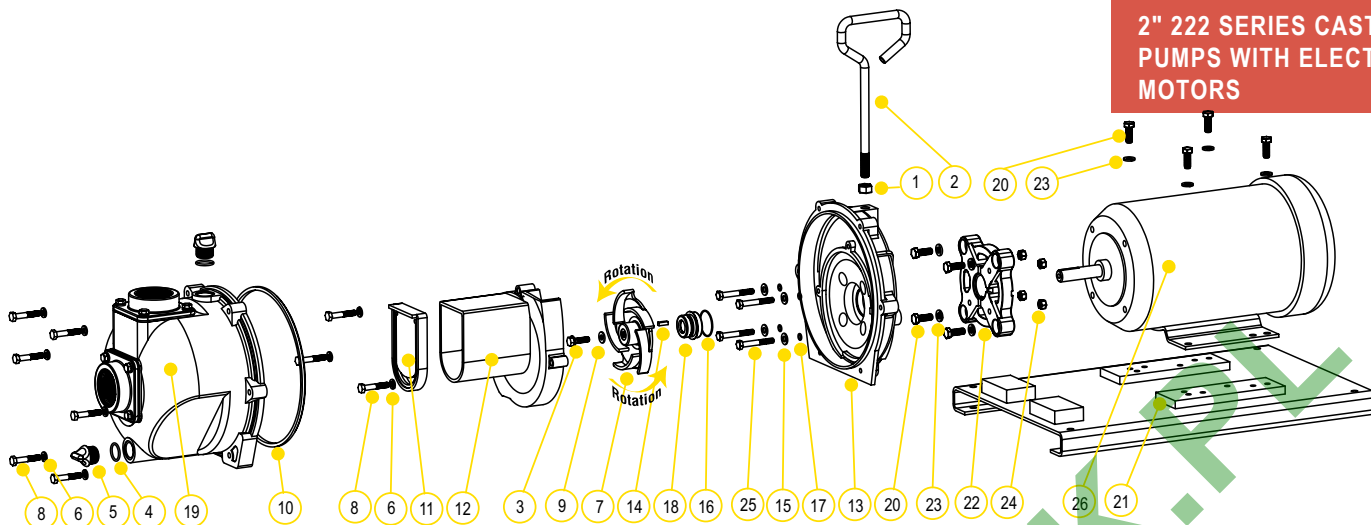

## REPLACEMENT PARTS 222 SERIES CAST IRON PUMPS

ITEM	PART NO	DESCRIPTION	QTY
1	17010	1/2" JAM NUT	1
2	15022	HANDLE	1
3	12765A	5/16" - 24 X 1.12 IMPELLER BOLT	1
4	13778	O-RING	2
5	13777	3/4" PLUG	2
6	V10118	5/16" LOCK WASHER	9
7	15772	5 VANE IMPELLER	1
8	12715A	5/16" - 24 X 1.75 HHCS	13
9	A204	O-RING	1
10	12719A	BODY O-RING	1
11	12705	CHECK VALVE	1
12	15702	VOLUTE	1
13	15703	REAR BRACKET	1
14	12902A	3/16" SQ. X 5/8" KEY	1
15	12901	5/16" FLAT WASHER	1
16	12710	O-RING	4
17	12717	O-RING	1
18	12713V	SEAL ASSEMBLY	4
18	N/A	SEVERE DUTY SEAL	1
19	15712	BODY	1
20	17704	3/16" - 16 X 1.25 HHCS BOLT	8
21	17701	C-FACED BASE PLATE	1
22	12046	56C ADAPTER	1
23	V20018	3/8" LOCK WASHER	8
24	V20019	3/8" 16 SS HEX NUT	4
25	N/A	5/16" - 18 X 2 1/4" HHCS BOLT	4
26	BEM5-182CZ	5 HP 3450 RPM THREE PHASE MOTOR	1
26	N/A	5 HP 3450 RPM SINGLE PHASE MOTOR	1
N/S	12099	7/16"-14 X 1.25" HHCS	1
N/S	15751	BRACKET SHIM	1
N/S	15752	IMPELLER SHIM	1
N/S	12756	ADAPTER KIT (ITEMS 14, 20, 22, 23, 12052, 12053, 15751, 15752, 17029)	1
N/S	15000	REPAIR KIT (ITEMS 4,7,9-11,14,16-18,12099,15751 & 15752)	1
N/S	15000V	FKM REPAIR KIT	1
N/S	15999	SEAL KIT (ITEMS 4, 9-11, 14,16-18,12099,15751 & 15752)	1
N/S	15999V	FKM SEAL KIT	1

## KITS 222 CAST IRON PUMPS

PART NO	EPDM REPAIR KIT NO	FKM REPAIR KIT NO	EPDM SEAL KIT NO	ADAPTER KIT NO
222PIE5	15000	15000V	15999	12756
222PIE51	15000	15000V	15999	12756

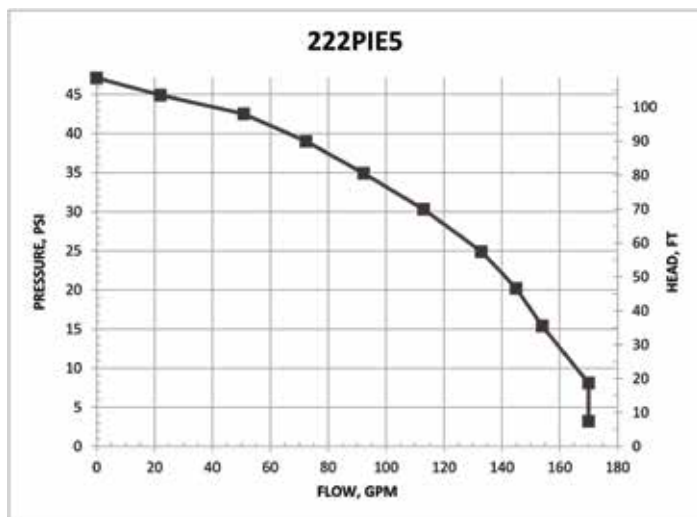

# CENTRIFUGAL PUMPS

## 3" CAST IRON PUMPS

### FEATURES

- Cast iron construction for rugged dependable service
- Stainless steel shaft sleeve to protect engine shaft
- Carbon ceramic seal with stainless steel cup and spring with FKM rubber
- Replaceable inlet and outlet flanges
- Dynamically balanced impeller
- Pump only packs complete and ready for attachment to gasoline engine
- Bearing pedestal pump for long coupling to electric motor
- Recommendation for 1" shaft: 184TC frame size, 7½ HP, 3450 RPM for close coupling to electric motors
- Engine warranty service available at authorized dealers
- Due to weight and size of pumps, Banjo ships these by truck only.



### 3" CAST IRON PUMP W/GAS ENGINES

PART NO	DESCRIPTION	HP	QTY
300PIH-8	3" CAST IRON PUMP W/8 HP HONDA® ENGINE W/ELECTRIC START & PULL ROPE	8	1
300PIH13	3" CAST IRON PUMP W/13 HP HONDA® ENGINE W/ELECTRIC START & PULL ROPE	13	1



### 3" CAST IRON PUMP ONLY

PART NO	DESCRIPTION	HP	QTY
300POI	3" CAST IRON PUMP ONLY W/ 1" SHAFT SLEEVE	N/A	1



WARNING! DO NOT RUN PUMP DRY, RESTRICT OR REDUCE PORT SIZES OR DEAD HEAD PUMP



WARNING! DO NOT USE WITH FLAMMABLE LIQUIDS



### 3" CAST IRON BEARING PEDESTAL

PART NO	DESCRIPTION	HP	QTY
300PBI	3" CAST IRON BEARING PEDESTAL W/ 1" STRAIGHT SHAFT	N/A	1

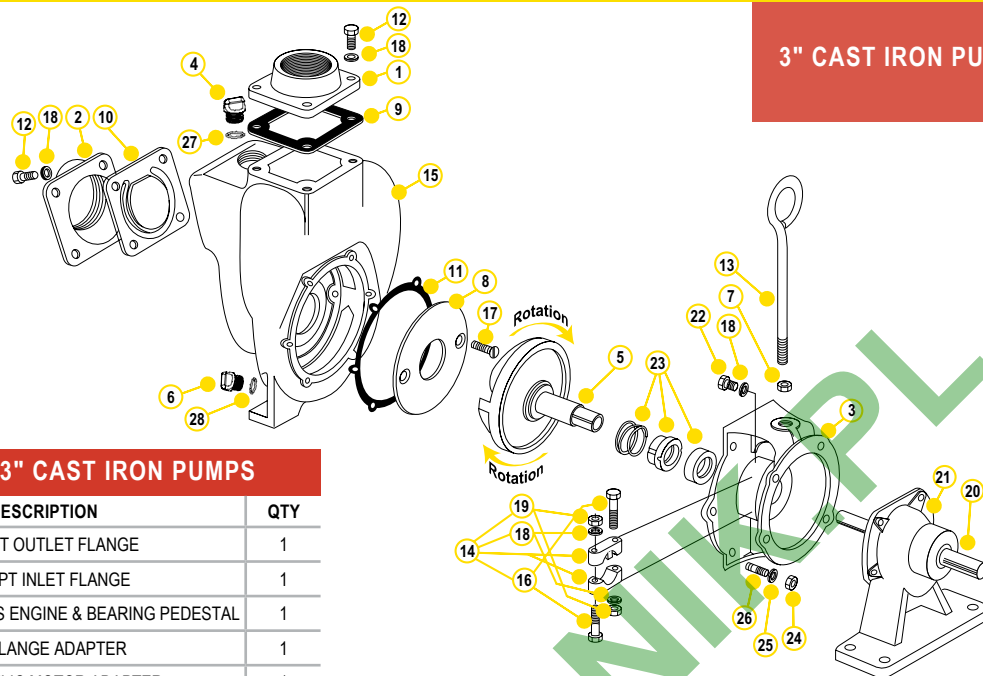

### REPLACEMENT PARTS 3" CAST IRON PUMPS

ITEM	PART NO	DESCRIPTION	QTY
1	18008	3" NPT OUTLET FLANGE	1
2	18012	3" NPT INLET FLANGE	1
3	18026	ADAPTER FOR GAS ENGINE & BEARING PEDESTAL	1
3	18048	C-FLANGE ADAPTER	1
3	18049	HYDRAULIC MOTOR ADAPTER	1
N/S	18055	HYDRAULIC ADAPTER SHAFT	1
4	13777	3/4" PLUG	1
5*	18023SS	1" IMPELLER & DRIVE SHAFT FOR GAS ENGINE	1
5	18023-1.125	1 1/8" IMPELLER & DRIVE SHAFT FOR ELECTRIC MOTOR	1
6	12777	1/2" PLUG	1
7	18034	5/8" SS JAM NUT	1
8	18004	WEAR PLATE	1
9	18009	EPDM OUTLET GASKET	1
10	18013	GASKET CHECK VALVE ASSEMBLY	1
11	18021	ADAPTER GASKET	1
12	18010SS	3/8" - 16 X 1 1/8" SS CAP SCREW HXHD	8
13	18033	HANDLE	1
14	18029	CLAMP ASSEMBLY (OLD STYLE)	1
14	18129	CLAMP ASSEMBLY (NEW STYLE)	1
15	18001	PUMP HOUSING	1
16	N/A	3/8" - 24 X 2 1/4" BOLT	2
17	18106	WEAR PLATE FLAT HEAD SCREW	2
18	V20018	3/8" LOCK WASHER	8
19	N/A	3/8" X 24 SS HEX NUT	2
20	18504	1" SHAFT	1
21	18500	BEARING PEDESTAL	1
N/S	18502	BEARING SKF 66306-2RS1/C3	2
22	17704	BOLT	4
23*	18025	FKM SEAL ASSEMBLY	1
23	18025SD	SEVERE DUTY SEAL	1
24	V20019	3/8" 16 SS HEX NUT	6
25	V20018	3/8" SS LOCK WASHER	6
26	18218	3/8" - 16 X 24 X 2 1/8" SS STUD	6
27	13778	O-RING	1
28	UV15163	O-RING	1
N/S	18035	Z-RAIL MOUNTING BRACKET (PAIR)	1
N/S	18100	REPAIR KIT (CONSIST OF ITEMS 5*, 8, 11, 17, 23*)	1

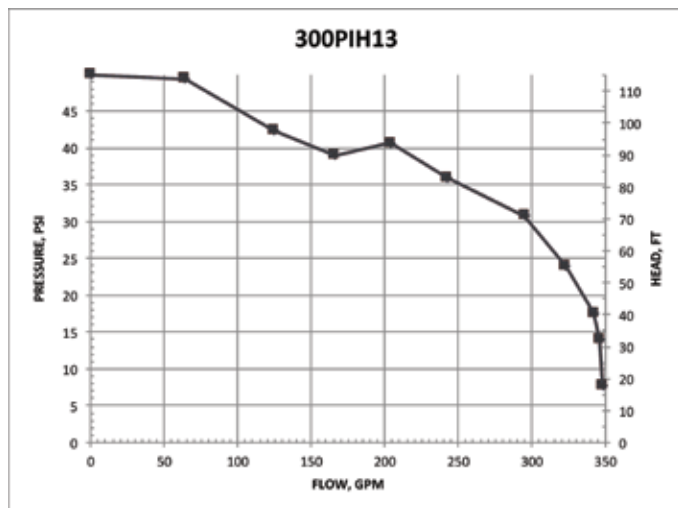

# CENTRIFUGAL PUMPS

## 3" CAST IRON WET SEAL PUMPS

### FEATURES

- Cast iron construction for rugged dependable service
- Run dry capability
- Stainless steel hardware
- Double seal contained in ethylene glycol reservoir
- Replaceable inlet and outlet flanges
- Dynamically balanced impeller
- Pump only packs complete and ready for attachment to gasoline engine
- Pedestal pump for long coupling to electric motor
- Due to weight and size of pumps, Banjo ships these by truck only.



**WARNING! DO NOT USE WITH FLAMMABLE LIQUIDS**



### 3" CAST IRON WET SEAL PUMPS W/GAS ENGINES

PART NO	DESCRIPTION	HP	QTY
301PIH13W	3" CAST IRON WET SEAL PUMP W/13 HP HONDA® ENGINE W/ ELECTRIC START & PULL ROPE	13	1



### 3" CAST IRON WET SEAL PUMP ONLY

PART NO	DESCRIPTION	HP	QTY
301POIW	3" CAST IRON WET SEAL PUMP ONLY	N/A	1



### 3" CAST IRON WET SEAL PUMP BEARING PEDESTAL

PART NO	DESCRIPTION	HP	QTY
301PBIW	3" CAST IRON WET SEAL PUMP WITH BEARING PEDESTAL	N/A	1

WWW.BANJO-ELECTRONICS.PL

# CENTRIFUGAL PUMPS

## 3" CAST IRON WET SEAL PUMPS

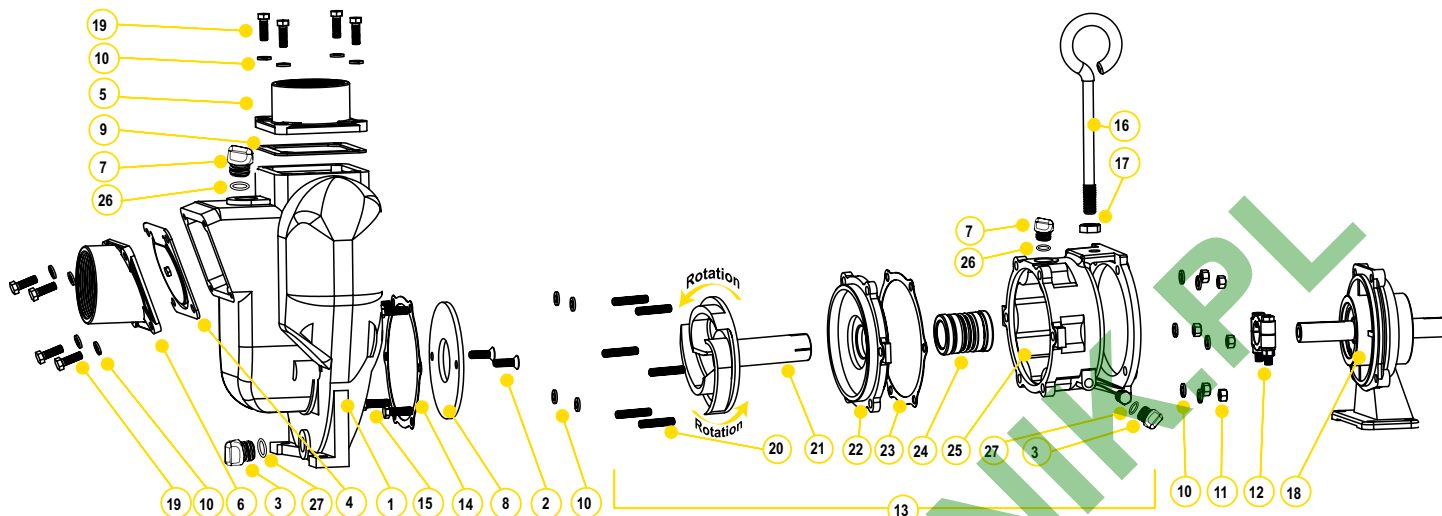

### REPLACEMENT PARTS 3" CAST IRON PUMPS

ITEM	PART NO	DESCRIPTION	QTY
1	18001	PUMP HOUSING	1
2	18106	FLAT HEAD SOCKET CAP SCREW	2
3	12777	1/2" PLUG	2
4	18013	INLET/CHECK EPDM GASKET	1
5	18008	3" NPT OUTLET FLANGE	1
6	18012	3" NPT INLET FLANGE	1
7	13777	3/4" PLUG	2
8	18004	WEAR PLATE	1
9	18009	EPDM OUTLET GASKET	1
10	V20018	3/8" LOCK WASHER	18
11	V20019	3/8" 16 SS HEX NUT	6
12	18129	CLAMP ASSEMBLY KEYED	1
13	18200A	WET SEAL ASSEMBLY	1
14	18021	ADAPTER GASKET	1
15	17704	3/8" -16 X 1 1/4" HHCS	4
16	18033	HANDLE	1
17	18034	5/8" -11 JAM NUT	1
18	18500	BEARING PEDESTAL	1
19	18010SS	3/8" - 16 X 1 1/8" HHCS	8
20	18218	3/8" -16 X 24 X 2 1/8" SS STUD	6
21	18206	IMPELLER	1
22	18202A	COVER PLATE	1
23	18021	ADAPTER GASKET	1
24	15035E	EPDM MECHANICAL SEAL ASSEMBLY	1
25	18203A	WET SEAL RESERVOIR	1
26	13778	O-RING	2
27	UV15163	O-RING	2

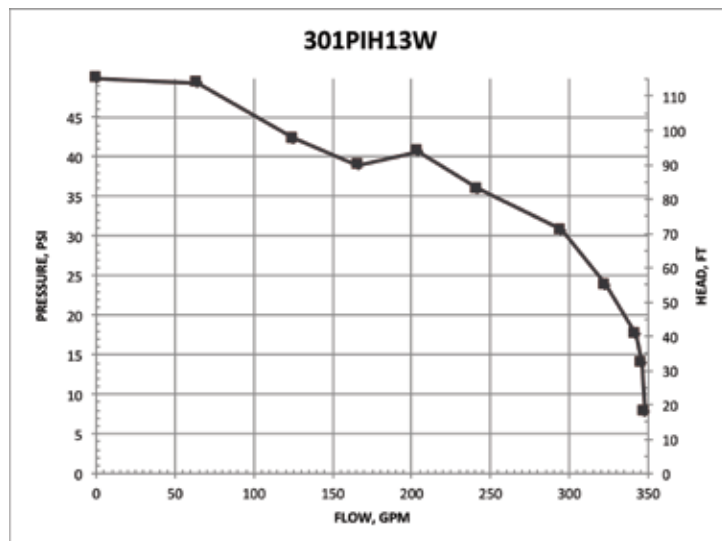

# CENTRIFUGAL PUMPS

## 3" CAST IRON PUMPS WITH HYDRAULIC MOTORS

### FEATURES

- Cast iron construction for rugged dependable service
- Stainless steel hardware
- Replaceable inlet and outlet flanges
- Dynamically balanced impeller
- Hydraulic fluid capacity is minimum 9 gallons and maximum 13 gallons
- Open or closed system
- 21 HP motor
- Recommendation to use the motor spool control valve or a suitable equivalent. The lack of such a valve in this circuit may cause failure to the hydraulic motor.



### 3" CAST IRON PUMPS W/ HYDRAULIC MOTORS

PART NO	DESCRIPTION	HP	QTY
300PIHY	3" CAST IRON PUMP W/ 21 HP HYDRAULIC MOTOR	21	1

### SPOOL VALVE ASSEMBLY DIAGRAM

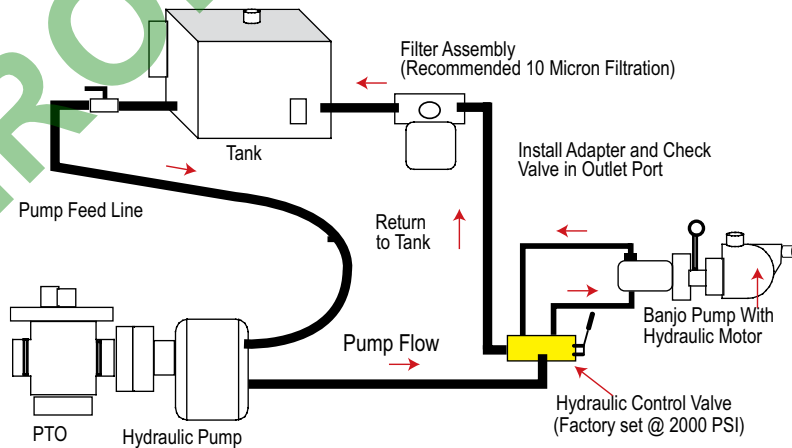

WARNING! DO NOT RUN PUMP DRY, RESTRICT OR REDUCE PORT SIZES OR DEAD HEAD PUMP



WARNING! DO NOT USE WITH FLAMMABLE LIQUIDS



### HYDRAULIC MOTOR SPOOL VALVE

PART NO	DESCRIPTION	HP	QTY
HSV1000	HYDRAULIC MOTOR SPOOL VALVE	N/A	1



# CENTRIFUGAL PUMPS

3" CAST IRON PUMPS WITH HYDRAULIC MOTORS

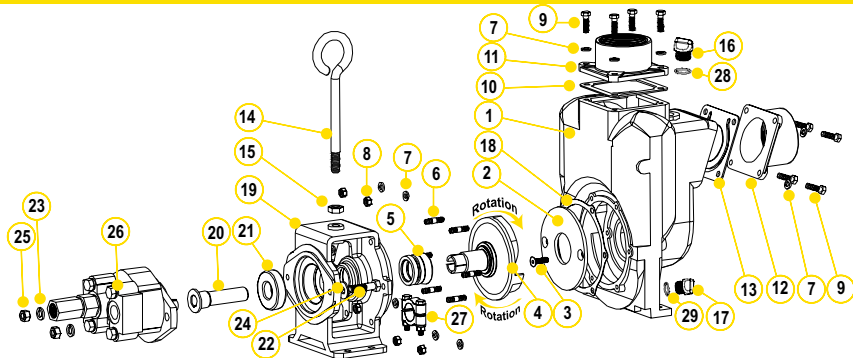

## REPLACEMENT PART 3" CAST IRON PUMPS

ITEM	PART NO	DESCRIPTION	QTY
1	18001	PUMP HOUSING	1
2	18004	WEAR PLATE	1
3	18106	3/8" - 16 X 1.25" HHCS	2
4	18023SS	1" IMPELLER & DRIVE SHAFT FOR GAS ENGINE	1
5	18025	FKM MECHANICAL SEAL	1
5	18025SD	SEVERE DUTY SEAL	1
6	18218	3/8" -16 X 24 X 2 1/8" SS STUD	6
7	V20018	3/8" LOCK WASHER	14
8	V20019	3/8" 16 SS HEX NUT	6
9	18010SS	3/8" - 16 X 1.25" HHCS	8
10	18009	EPDM OUTLET GASKET	1
11	18008	3" NPT OUTLET FLANGE	1
12	18012	3" NPT INLET FLANGE	1
13	18013	INLET/CHECK EPDM GASKET	1
14	18033	HANDLE	1
15	18034	5/8" -11 HEX NUT	1
16	13777	3/4" PLUG	1
17	12777	1/2" PLUG	1
18	18021	ADAPTER GASKET	1
19	18049	HYDRAULIC MOTOR ADAPTER	1
20	18055	HYDRAULIC ADAPTER SHAFT	1
21	18502	BEARING SKF 66306-2RS1/C3	1
22	18056	1/2" -13 X 2" HHCS	2
23	N/A	1/2" SPLIT WASHER	2
24	N/A	1/2" FLAT WASHER	2
25	17010	1/2" - 13 HEX NUT	2
26	HY1012	UM16-45A-HX HYDRAULIC MOTOR ASSEMBLY	1
27	18029	CLAMP ASSEMBLY UNKEYED	1
28	13778	O-RING	1
29	UV15163	O-RING	1
KIT	18100	REPAIR KIT (CONSIST OF 2, 3, 4, 5, 18)	1

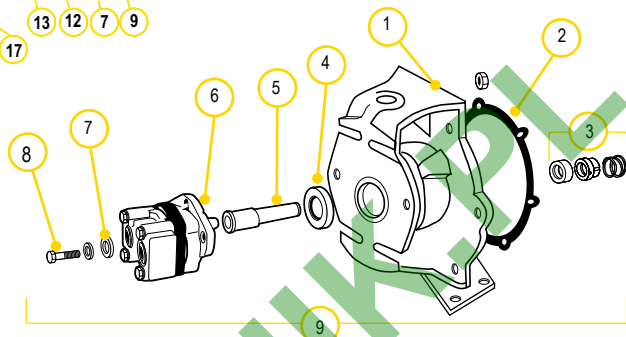

## REPLACEMENT PARTS 3" HYDRAULIC ADAPTER

ITEM	PART NO	DESCRIPTION	QTY
1	18049	C-FACE HYDRAULIC MOTOR ADAPTER	1
2	18021	GASKET ADAPTER	1
3	18025	SEAL ASSEMBLY	1
4	18502	SKF 63306-2RS1/C3 BEARING	1
5	18055	HYDRAULIC ADAPTER SHAFT SLEEVE	1
6	HY1012	TYRONE® UM16 HYDRAULIC MOTOR	1
7	N/A	1/2" FLAT WASHER	2
8	N/A	1/2" SPLIT LOCK WASHER	2
9	18056	1/2" - 13" X 2" HHCS BOLT	2
10	17010	1/2" HEX NUT	2
11	18600	HYDRAULIC MOTOR ADAPTER ASSEMBLY	1
KIT	HY1001	REPAIR KIT	1

## HYDRAULIC MOTOR DATA

U.S. GALLONS/REV.	0.0038
CUBIC INCHES/REV.	0.878
LITERS/REV.	0.0144
MAX HYDRAULIC PRESSURE	3000 PSI
MIN HYDRAULIC PRESSURE	600 PSI
INLET PORT	1-1/16-12UN-2B
OUTLET PORT	1-5/16-12UN-2B
MINIMUM GPM REQUIRED	9 GPM 2370 RPM
MAXIMUM GPM REQUIRED	13 GPM 3450 RPM
IDEAL GPM REQUIRED	9 GPM 3600 RPM

## CONNECTION INFORMATION

INLET	"A" PORT
OUTLET	"B" PORT

SUPPLIED CHECK VALVE IS TO ENSURE PROPER ROTATION OF THE BANJO PUMP. PLACE CHECK VALVE IN OUTLET PORT (MARKED "B") FOR PROPER RIGHT HAND ROTATION. IT IS RECOMMENDED THAT A MINIMUM 3/4" INLET LINE & A MINIMUM 1" OUTLET LINE BE USED. THE OUTLET PORT MUST BE CONNECTED DIRECTLY BACK TO THE HYDRAULIC FLUID RESERVOIR & NOT TO ANY VALVING, REGULATORS OR FLOW DIVERTERS. THE OUTLET PORT/RETURN LINE BACK PRESSURE MUST NOT EXCEED 250 PSI.

## SPOOL VALVE INFORMATION

REQUIRED OUTLET FLOW	MIN 9 GPM / MAX 13 GPM
REQUIRED SYSTEM PRESSURE	MIN 600 PSI / MAX 3000 PSI

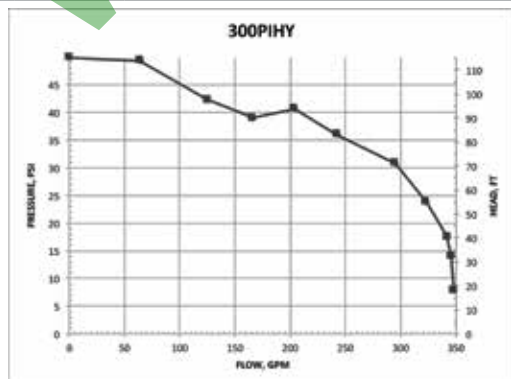

# CENTRIFUGAL PUMPS

## 3" 333 SERIES CAST IRON PUMPS

POWERED by  
**HONDA**

### FEATURES

- Cast iron construction for rugged dependable service
- Carbon ceramic seal with stainless steel cup and spring with FKM rubber
- Replaceable inlet and outlet flanges
- Dynamically balanced impeller
- Heavy duty slinger seal on motor shaft
- Large weep holes between pump end and engine
- Pedestal pump for long coupling to electric motor
- Due to weight and size of pumps, Banjo ships these by truck only.
- Engine warranty service available at authorized dealers



### 333 SERIES CAST IRON PUMPS W/GAS ENGINES

PART NO	DESCRIPTION	HP	QTY
333PIH13	3" CAST IRON PUMP W/13 HP HONDA® ENGINE W/ ELECTRIC START & PULL ROPE	13	1



### 333 SERIES CAST IRON PUMP ONLYS

PART NO	DESCRIPTION	HP	QTY
333POI	3" CAST IRON PUMP ONLY W/1" SHAFT & 5 VANE IMPELLER UNASSEMBLED	N/A	1



### 333 SERIES CAST IRON BEARING PEDESTAL

PART NO	DESCRIPTION	HP	QTY
333PBI	3" CAST IRON BEARING PEDESTAL W/ 1" SHAFT	N/A	1



WARNING! DO NOT RUN PUMP DRY, RESTRICT OR REDUCE PORT SIZES OR DEAD HEAD PUMP



WARNING! DO NOT USE WITH FLAMMABLE LIQUIDS



### 333 SERIES CAST IRON HYDRAULIC PUMPS

PART NO	DESCRIPTION	HP	QTY
333PIE15	3" CAST IRON PUMP W/15 HP THREE PHASE ELECTRIC MOTOR	15	1

# CENTRIFUGAL PUMPS

## 3" 333 SERIES CAST IRON PUMPS

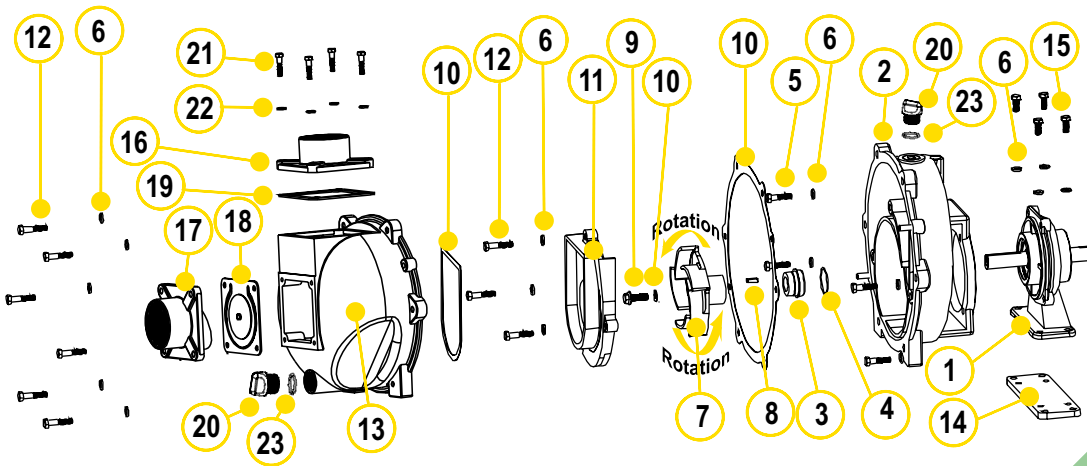

### REPLACEMENT PARTS 3" CAST IRON PUMPS

ITEM	PART NO	DESCRIPTION	QTY
N/S	16099	IMPELLER REMOVAL BOLT	1
1	18500	BEARING PEDESTAL (333PBI)	1
2	16704	REAR BRACKET	1
3	16713	MECHANICAL SEAL	1
4	16710	O-RING	1
5	17704	3/8" - 16 X 1.25" SS CAP SCREW (333PBI)	4
6	V20018	3/8" SS LOCK WASHER	17
7	16773	3" IMPELLER (333PBI)	1
7	16774	3" IMPELLER (333PIH13 & 333POI)	1
8	16901	1/4" SQ. 3/4" KEY STOCK	1
9	16765	IMPELLER BOLT (333PBI)	1
9	13765	IMPELLER BOLT (333PIH13)	1
10	16019	GASKET SET	1
11	16702	VOLUTE	1
12	N/A	3/8" - 16 X 1.75" SS BOLT	9
13	16733	BODY	1
14	18511	ADAPTER PLATE (333PBI)	1
15	18512	3/8" - 16 X 0.875" SS HHCS (333PBI)	4
N/S	16751	BRACKET SHIM SET	1
N/S	16752	IMPELLER SHIM	1
N/S	18033	HANDLE	1
N/S	18034	5/8" SS JAM NUT	1
16	16001	3" NPT OUTLET FLANGE	1
17	16003	3" NPT INLET FLANGE	1
18	16706	FKM INLET GASKET W/ CHECK	1
19	16011	FKM OUTLET GASKET	1
20	13777	3/4" PLUG	2
21	18027	3/8" - 16 X 1.50" HHCS (333PIH13)	8
22	V20018	3/8" SS LOCK WASHER	8
23	13778	O-RING	2

### REPLACEMENT PARTS 333PIE15

ITEM	PART NO	DESCRIPTION	QTY
N/S	16099	IMPELLER REMOVAL BOLT	1
2	16704A	REAR BRACKET W/C-FACE ADAPTER	1
3	15025	MECHANICAL SEAL	1
6	V20018	3/8" SS LOCK WASHER	8
7	N/A	3" IMPELLER - 5 VANE	1
8	N/A	1/4" SQ. 3/4" KEY STOCK	1
9	16765	7/16-20 1 1/4" HFS	1
10	16019	GASKET SET	1
11	16702	VOLUTE	1
12	V20011SS	3/8" - 16 X 1.75" SS BOLT	9
13	16733	BODY	1
N/S	16751	BRACKET SHIM SET	1
N/S	16752	IMPELLER SHIM	1
N/S	18033	HANDLE	1
N/S	18034	5/8" SS JAM NUT	1
16	16001	OUTLET FLANGE	1
17	16003	INLET FLANGE	1
18	16706	FKM INLET GASKET W/ CHECK	1
19	16011	FKM OUTLET GASKET	1
20	13777	3/4" PLUG	2
21	18027	3/8" - 16 X 1.50" HHCS	8
22	V20018	3/8" SS LOCK WASHER	4
23	13778	O-RING	2

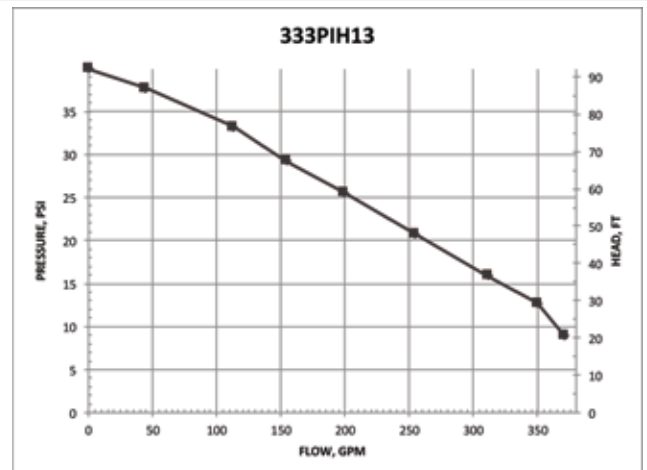

# CENTRIFUGAL PUMPS

## 3" M332 SERIES CAST IRON MANIFOLD WET SEAL PUMPS

### FEATURES

- Run dry capability
- Cast iron construction for rugged dependable service
- Carbon ceramic seal with stainless steel cup and spring with EPDM rubber
- Replaceable inlet and outlet flanges
- Dynamically balanced impeller
- Heavy duty slinger seal on motor shaft
- Due to weight and size of pumps, Banjo ships these by truck only.
- Engine warranty service available at authorized dealers
- See pages 39-45 on manifold fittings for easy plumbing.



WARNING! DO NOT USE WITH FLAMMABLE LIQUIDS



### M332 SERIES CAST IRON WET SEAL PUMPS W/GAS ENGINES

PART NO	DESCRIPTION	HP	QTY
M332PIH13W	3" MANIFOLD CAST IRON WET SEAL PUMP W/13 HP HONDA® ENGINE W/ELECTRIC START & PULL ROPE	13	1



### M332 SERIES CAST IRON WET SEAL PUMPS W/ELECTRIC MOTORS

PART NO	DESCRIPTION	HP	QTY
M332PIE10W	3" MANIFOLD CAST IRON WET SEAL PUMP W/10HP THREE PHASE ELECTRIC MOTOR	10	1
M332PIE101W	3" MANIFOLD CAST IRON WET SEAL PUMP W/10HP SINGLE PHASE ELECTRIC MOTOR	10	1

### M332 SERIES CAST IRON WET SEAL PUMP ONLY

PART NO	DESCRIPTION	HP	QTY
M332POIW	3" MANIFOLD CAST IRON WET SEAL PUMP ONLY	N/A	1

# CENTRIFUGAL PUMPS

2" M332 SERIES CAST IRON MANIFOLD WET SEAL PUMPS

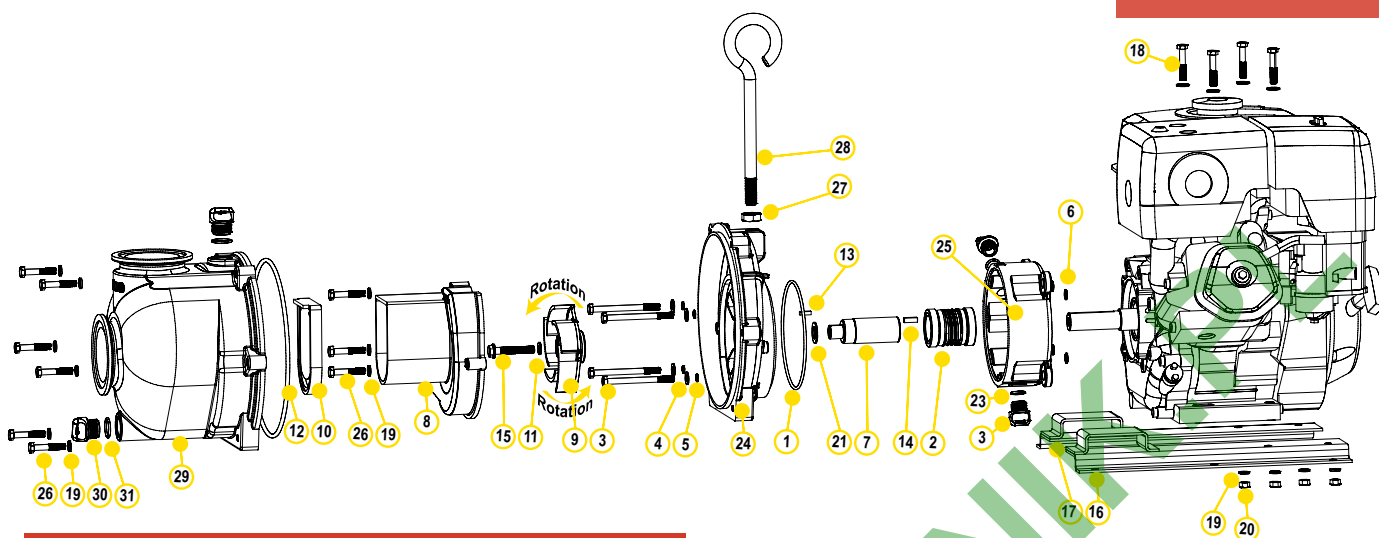

## REPLACEMENT PARTS M332 SERIES CAST IRON PUMPS

ITEM	PART NO	DESCRIPTION	QTY
1	13719	O-RING	1
2	15035E	EPDM MECHANICAL SEAL ASSEMBLY	1
3	13034	5/16" - 24 X 3 3/4" HHCS	1
4	12901	5/16" FLAT WASHER	4
5	12717	O-RING FOR BRACKET SCREW	8
6	12709	O-RING	4
7	13055	ADAPTER SHAFT	4
8	19702	VOLUTE	1
9	19772SS	5 VANE IMPELLER	1
9	15772	IMPELLER (M332PBIW)	1
10	12705	CHECK VALVE	1
11	A204	O-RING	1
12	12719A	BODY O-RING	1
13	12902A	IMPELLER KEY	1
14	16901	1/4" SQ X 3/4" KEY STOCK	1
15	13766	3/8" - 24 X 2 1/4" HFS	1
16	N/A	Z-RAIL	1
17	N/A	Z-RAIL	1
18	N/A	5/16" - 18 X 1 1/4" HHCS	4
19	V10118	5/16" LOCK WASHER	13
20	V10119	5/16" HEX NUT	4
21	CV10175	GASKET	2
22	12777	1/2" PLUG	2
23	UV15163	O-RING	2
24	19703W	REAR BRACKET	1
25	19201W	WET SEAL RESERVOIR	1
26	12715A	5/16" - 24 X 1 3/4" HHCS	9
27	18034	5/8"-11 JAM NUT	1
28	18033	PUMP HANDLE	1
29	M19712X	PUMP BODY	1
30	13777	3/4" PLUG	2
31	13778	O-RING	2

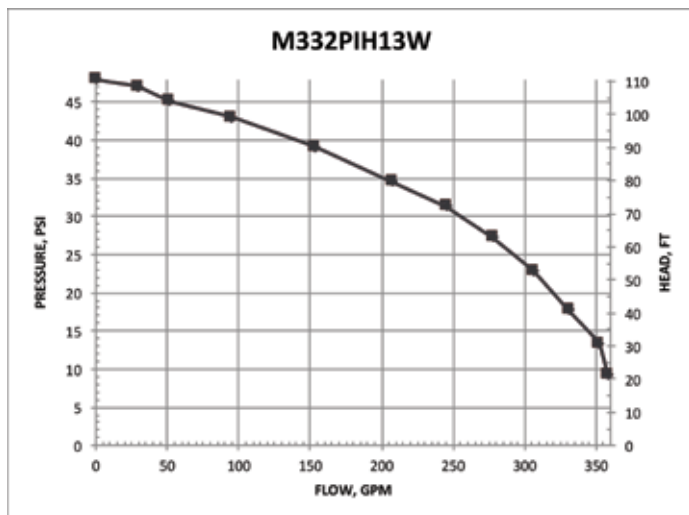

# CENTRIFUGAL PUMPS

## 3" M332 SERIES CAST IRON MANIFOLD WET SEAL PUMPS WITH HYDRAULIC MOTORS

### FEATURES

- Run dry capability
- Cast iron construction for rugged dependable service
- Carbon ceramic seal with stainless steel cup and spring with EPDM rubber
- Replaceable inlet and outlet flanges
- Dynamically balanced impeller
- Heavy duty slinger seal on motor shaft
- Hydraulic fluid capacity is minimum 9 gallons and maximum 13 gallons
- Open or closed system
- 3600 R.P.M.
- Recommendation to use the motor spool control valve or a suitable equivalent. The lack of such a valve in this circuit may cause failure to the hydraulic motor.
- See pages 39-45 on manifold fittings for easy plumbing.



WARNING! DO NOT USE WITH FLAMMABLE LIQUIDS



### M332 SERIES CAST IRON MANIFOLD WET SEAL PUMPS W/O HYDRAULIC MOTOR

PART NO	DESCRIPTION	HP	QTY
M332PIHYW	3" MANIFOLD CAST IRON WET SEAL PUMP W/HYDRAULIC MOTOR	21	1

### SPOOL VALVE ASSEMBLY DIAGRAM

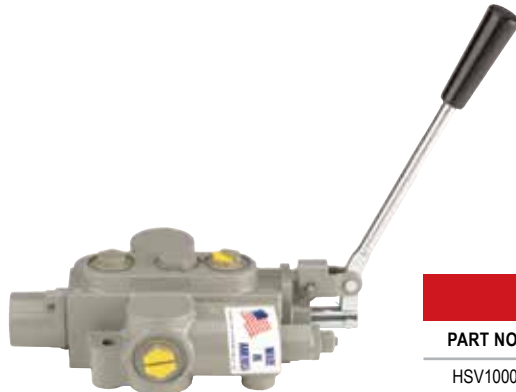
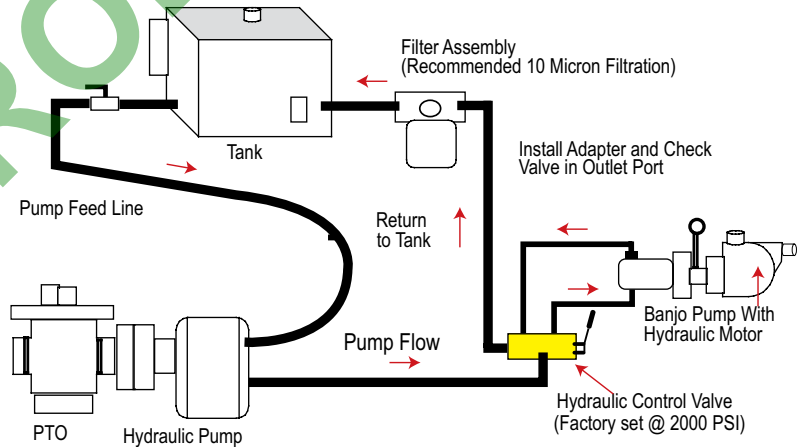

### HYDRAULIC MOTOR SPOOL VALVE

PART NO	DESCRIPTION	HP	QTY
HSV1000	HYDRAULIC MOTOR SPOOL VALVE	N/A	1

# CENTRIFUGAL PUMPS

3" M332 SERIES CAST IRON MANIFOLD WET SEAL PUMPS WITH HYDRAULIC MOTORS

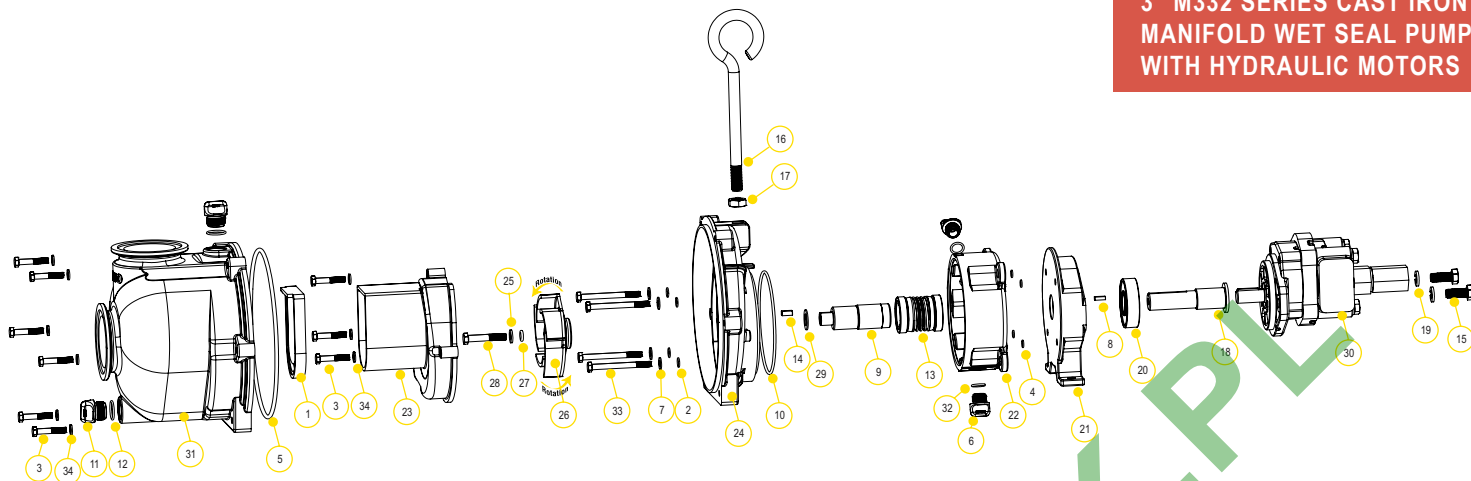

## REPLACEMENT PARTS M332 SERIES CAST IRON PUMPS

ITEM	PART NO	DESCRIPTION	QTY
1	12705	CHECK VALVE	1
2	12709	O-RING	4
3	12715A	SS BRACKET SCREWS-	9
4	12717	O-RING FOR SCREW HEAD	4
5	12719A	BODY O-RING	1
6	12777	1/2" PLUG	2
7	12901	SS REAR BRACKET WASHER	4
8	12902A	IMPELLER KEY	1
9	13055	ADAPTER SHAFT	1
10	13719	O-RING	1
11	13777	3/4" PLUG	2
12	13778	O-RING	2
13	15035E	EPDM MECHANICAL SEAL ASSEMBLY	1
14	16901	1/4" SQ. 3/4" KEY STOCK	1
15	N/A	BOLT	2
16	18033	HANDLE	1
17	18034	5/8" SS JAM NUT	1
18	18055H	HYDRAULIC MOTOR ADAPTER SHAFT	1
19	N/A	1/2" SPLIT LOCK WASHER	2
20	18502	SKF 63306-2RS1/C3 BEARING	1
21	19001H	RESERVOIR BACKING PLATE	1
22	19201W	WET SEAL RESERVOIR	1
23	19702	VOLUTE	1
24	19703W	REAR BRACKET	1
25	19766	3/8" FLAT WASHER	1
26	19772SS	5 VANE IMPELLER	1
27	A204	O-RING	1
28	N/A	3/8" - 16 X 2 1/4" HHCS	1
29	CV10175	GASKET	1
30	HY1012	TYRONE® UM16 HYDRAULIC MOTOR	1
31	M19712X	PUMP BODY	1
32	UV15163	PRIME/DRAIN PLUG O-RING	2
33	V10118	5/16" SS LOCK WASHER	4
34	N/A	5/16" X 3 1/2" SS BODY BOLT	9

## HYDRAULIC MOTOR DATA

U.S. GALLONS/REV.	0.0038
CUBIC INCHES/REV.	0.878
LITERS/REV.	0.0144
MAX HYDRAULIC PRESSURE	3000 PSI
MIN HYDRAULIC PRESSURE	600 PSI
INLET PORT	1-1/16-12UN-2B
OUTLET PORT	1-5/16-12UN-2B
MINIMUM GPM REQUIRED	9 GPM 2370 RPM
MAXIMUM GPM REQUIRED	13 GPM 3450 RPM
IDEAL GPM REQUIRED	9 GPM 3600 RPM

## CONNECTION INFORMATION

INLET	"A" PORT
OUTLET	"B" PORT

SUPPLIED CHECK VALVE IS TO ENSURE PROPER ROTATION OF THE BANJO PUMP. PLACE CHECK VALVE IN OUTLET PORT (MARKED "B") FOR PROPER RIGHT HAND ROTATION. IT IS RECOMMENDED THAT A MINIMUM 3/4" INLET LINE & A MINIMUM 1" OUTLET LINE BE USED. THE OUTLET PORT MUST BE CONNECTED DIRECTLY BACK TO THE HYDRAULIC FLUID RESERVOIR & NOT TO ANY VALVING, REGULATORS OR FLOW DIVERTERS. THE OUTLET PORT/RETURN LINE BACK PRESSURE MUST NOT EXCEED 250 PSI.

## SPOOL VALVE INFORMATION

REQUIRED OUTLET FLOW	MIN 9 GPM / MAX 13 GPM
REQUIRED SYSTEM PRESSURE	MIN 600 PSI / MAX 3000 PSI

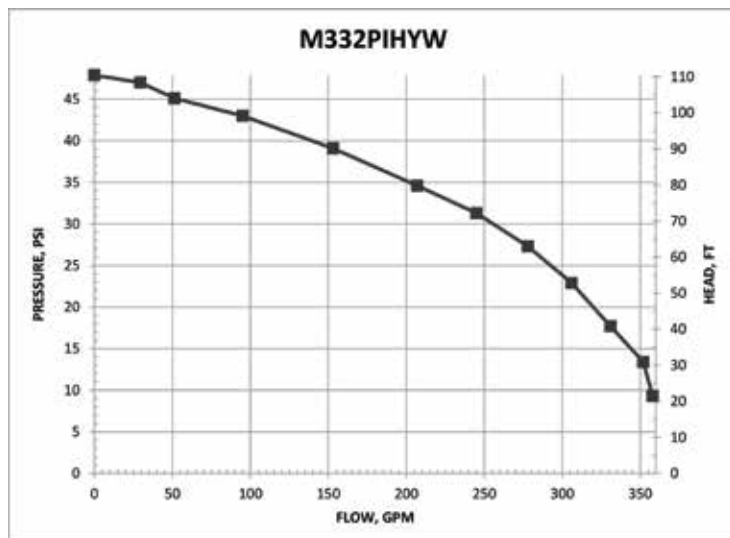

# CENTRIFUGAL PUMPS

## 4" 444 SERIES CAST IRON PUMPS

### FEATURES

- Cast iron construction for rugged dependable service
- Carbon ceramic seal with stainless steel cup and spring with FKM rubber
- Replaceable inlet and outlet flanges
- Dynamically balanced impeller
- Heavy duty slinger seal on motor shaft
- Large weep holes between pump end and engine
- Recommendation for 444POI: use with 10 pound per gallon material or more
- Due to weight and size of pumps, Banjo ships these by truck only.
- Engine warranty service available at authorized dealers



### 444 SERIES CAST IRON PUMPS W/GAS ENGINES

PART NO	DESCRIPTION	HP	QTY
444PIH24	4" CAST IRON PUMP W/24 HP HONDA® ENGINE	24	1



WARNING! DO NOT RUN PUMP DRY, RESTRICT OR REDUCE PORT SIZES OR DEAD HEAD PUMP



WARNING! DO NOT USE WITH FLAMMABLE LIQUIDS



### 444 SERIES CAST IRON PUMP ONLYS

PART NO	DESCRIPTION	HP	QTY
444POI	4" CAST IRON PUMP ONLY W/ 1 1/4" X 3 3/8" SHAFT & 6 VANE IMPELLER UNASSEMBLED	N/A	1



# CENTRIFUGAL PUMPS

4" 444 SERIES CAST IRON PUMPS

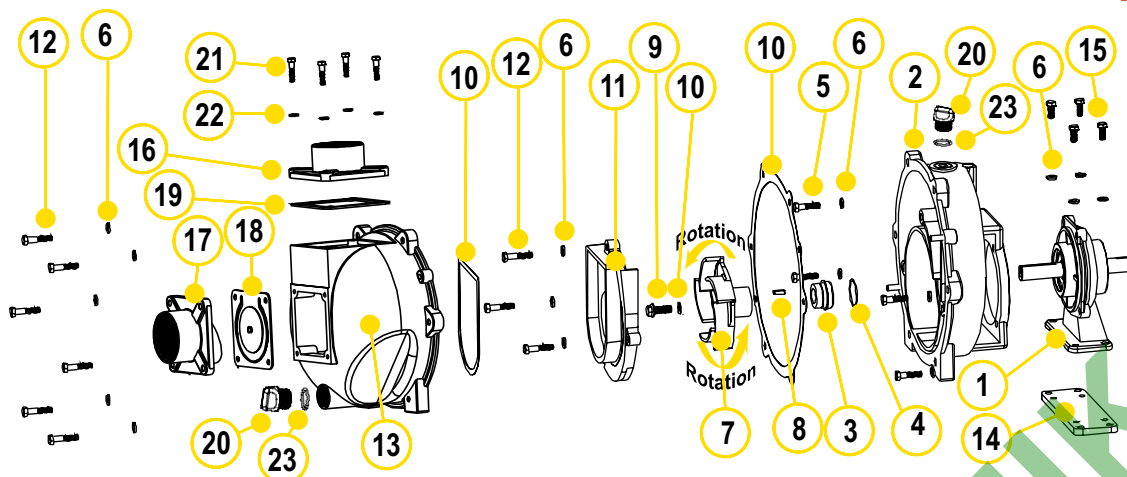

## REPLACEMENT PARTS 4" CAST IRON PUMPS

ITEM	PART NO	DESCRIPTION	QTY
2	16707	REAR BRACKET	1
3	18435	MECHANICAL SEAL	1
4	V10264	O-RING	1
5	17704	3/8" - 16 X 1.25" SS CAP SCREW	4
6	V20018	3/8" SS LOCK WASHER	13
7	16775	4" IMPELLER	1
8	16901	1/4" SQ. 3/4" KEY STOCK	1
9	16765	IMPELLER BOLT	1
10	16019	GASKET SET	1
11	16702	VOLUTE	1
12	N/A	3/8" - 16 X 1.75" SS BOLT	9
13	16712	BODY	1
16	16000	4" NPT OUTLET FLANG4E	1
17	16002	4" NPT INLET FLANGE	1
18	16706	INLET GASKET W/ CHECK	1
19	16011	OUTLET GASKET	1
20	13777	3/4" PLUG	2
21	18027	3/8" - 16 X 1.50" HHCS	8
22	V20018	3/8" SS LOCK WASHER	8
23	13778	O-RING	2
N/S	16099	IMPELLER REMOVAL BOLT	1
N/S	16751	BRACKET SHIM SET	1
N/S	16752	IMPELLER SHIM	1
N/S	18033	HANDLE	1
N/S	18034	5/8" SS JAM NUT	1

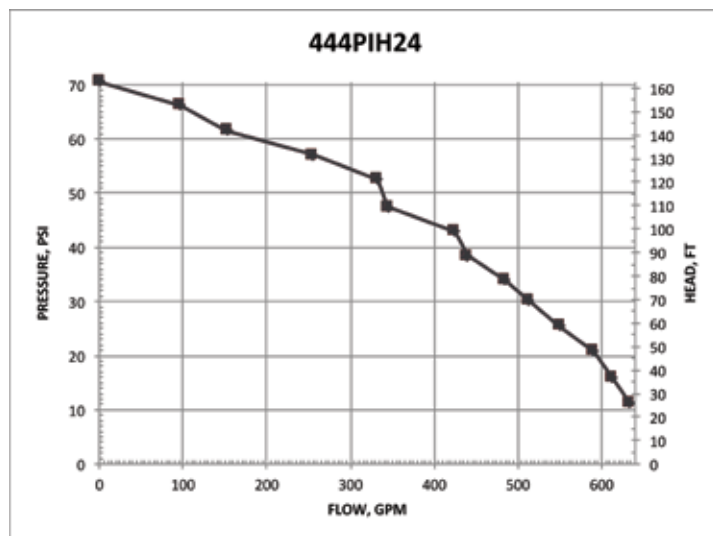

# CENTRIFUGAL PUMPS

## 2" STAINLESS STEEL PUMPS

### FEATURES

- 316 stainless steel housing and wettable internal components including impeller, sleeve, wear plate and fasteners
- Carbon ceramic seal with 316 stainless steel cup and spring with FKM elastomer
- Replaceable inlet and outlet flanges
- Dynamically balanced impeller
- Pump only packs complete and ready for attachment to gasoline engine
- Pedestal pump for long coupling to electric motor
- Recommendation for  $\frac{5}{8}$ " shaft: 56C frame size, 3 HP, 3450 RPM & 5" max impeller for close coupling to electric motors
- Recommendation for  $\frac{7}{8}$ " shaft: 145TC frame size, 3 HP, 3450 RPM & 5" max impeller for close coupling to electric motors
- Engine warranty service available at authorized dealers
- Due to weight and size of pumps, Banjo ships these by truck only.



### 2" STAINLESS STEEL PUMPS W/GAS ENGINES

PART NO	DESCRIPTION	HP	QTY
200PH5-SS	2" SS PUMP W/5.5 HP HONDA® ENGINE W/ PULL ROPE ONLY	5.5	1

### 2" STAINLESS STEEL PUMP ONLY

PART NO	DESCRIPTION	HP	QTY
200PO-SS	2" SS PUMP ONLY W/ $\frac{3}{4}$ " SHAFT SLEEVE	N/A	1

### 2" STAINLESS STEEL C-FACE PUMPS

PART NO	DESCRIPTION	HP	QTY
200POSSCF5/8	2" SS C-FACE PUMP W/ $\frac{5}{8}$ " SHAFT SLEEVE	N/A	1

### 2" STAINLESS STEEL BEARING PEDESTAL

PART NO	DESCRIPTION	HP	QTY
200PB-SS	2" SS BEARING PEDESTAL W/ $\frac{3}{4}$ " STRAIGHT SHAFT*	N/A	1



WARNING! DO NOT RUN PUMP DRY, RESTRICT OR REDUCE PORT SIZES OR DEAD HEAD PUMP



WARNING! DO NOT USE WITH FLAMMABLE LIQUIDS

# CENTRIFUGAL PUMPS

## 2" STAINLESS STEEL PUMPS

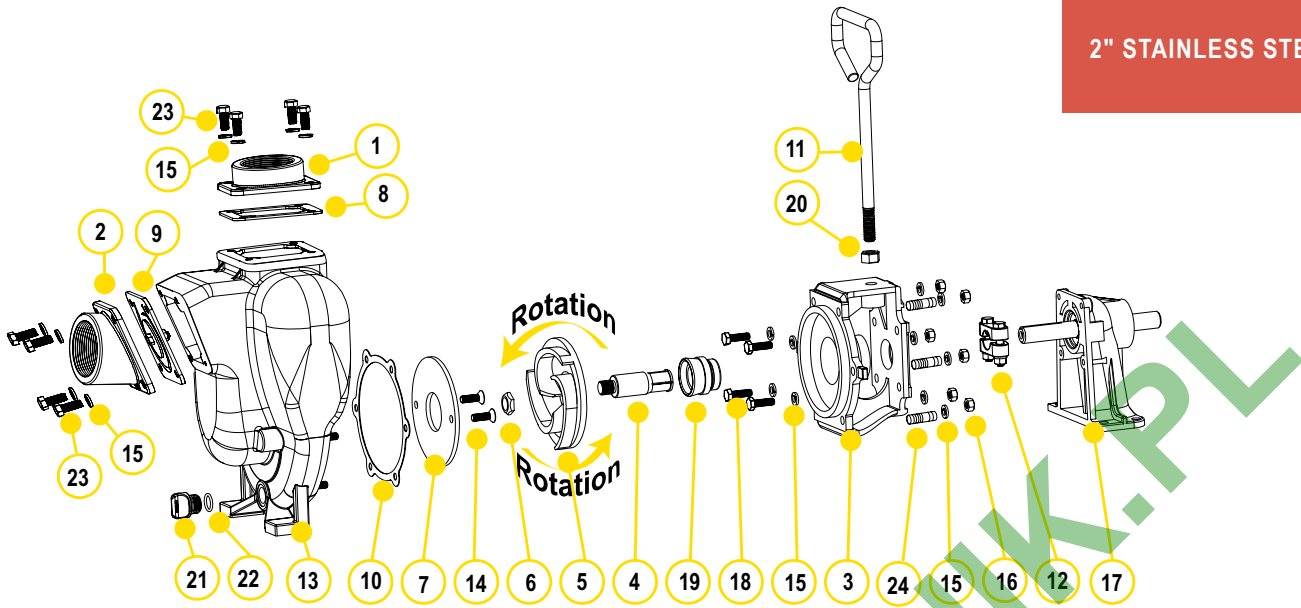

### REPLACEMENT PARTS 2" STAINLESS STEEL PUMPS

ITEM	PART NO	DESCRIPTION	QTY
1	17000SS	2" NPT SS OUTLET FLANGE	1
2	17002SS	2" NPT SS INLET FLANGE	1
3	N/A	SS ADAPTER FOR GAS ENGINE	1
3	17046SS	CF ADAPTER FOR ELECTRIC MOTOR	1
4	17005	5/8" SS SLEEVE DRIVE	1
4	17006	3/4" SS SLEEVE DRIVE	1
4	17007	7/8" SS SLEEVE DRIVE	1
5	17008SS	SS IMPELLER	1
5	N/A	4.1" SS IMPELLER	1
5	N/A	4.6" SS IMPELLER	1
6	17009B	5/8" IMPELLER NUT	1
7	17011SS	SS WEAR PLATE	1
8	17014	FKM OUTLET GASKET	1
9	17017	FKM CHECK VALVE ASSEMBLY GASKET	1
10	17018	ADAPTER GASKET	1
11	15022	HANDLE	1
12	17023	5/8" CLAMP, 3/4" SS SHAFT (OLD STYLE)	1
12	17123	5/8" CLAMP, 3/4" SS SHAFT (KEYED CLAMP)	1
12	17024	7/8" CLAMP, 3/4" SS SHAFT	1
13	17026SS	SS PUMP HOUSING	1
14	17130SS	5/16-18 X 1.00" FHSCS, 316 SS	2
15	V10118	5/16" LOCK WASHER	18
16	V10119	5/16" -18 SS HEX NUT	6
17	12882A	BEARING PEDESTAL ASSEMBLY W/ 3/4" SHAFT	1
18	17040	BOLT	4
19	17035SS	FKM SS SEAL ASSEMBLY	1
20	17010	1/2" - 24 X 1" HHCS	1
21	12777SS	1/2" STAINLESS STEEL PLUG	1
22	UV15163V	O-RING FKM	1
23	17019	5/16" - 18 X 3/4" CAP SCREW	8
24	17042	STUD	6
KIT	17100SS	PUMP REPAIR KIT (CONSISTS OF 4,5,7,10,14,19)	1

### KITS 2" STAINLESS STEEL PUMPS

PART NO	FKM REPAIR KIT NO	FKM SEAL KIT NO
200PH5-SS	17100SS	17035SS
200PB-SS	17100SS	17035SS
200PO-SS	17100SS	17035SS

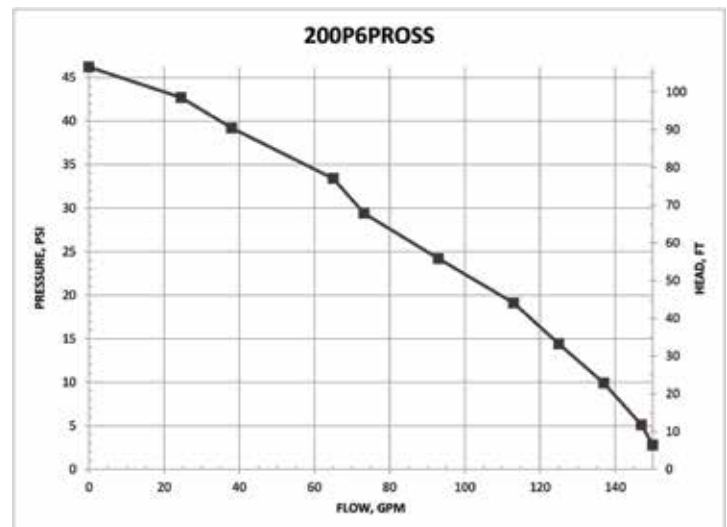

# CENTRIFUGAL PUMPS

## 2" STAINLESS STEEL PUMPS WITH ELECTRIC MOTORS

### FEATURES

- Stainless steel construction for rugged dependable service
- Stainless steel shaft sleeve to protect engine shaft
- Replaceable inlet and outlet flanges
- Dynamically balanced impeller
- Due to weight and size of pumps, Banjo ships these by truck only.
- Motor warranty service available at authorized dealers
- Motor features include pressure cast aluminum end plates with ribbed design for rigidity, heavy gauge steel frame, 230 volt, with inverter spike resistance magnet wire



### 2" STAINLESS STEEL PUMPS W/ELECTRIC MOTORS

PART NO	DESCRIPTION	HP	QTY
234PE5SS	2" STAINLESS STEEL PUMP W/5 HP THREE PHASE ELECTRIC MOTOR	5	1



WARNING! DO NOT RUN PUMP DRY, RESTRICT OR REDUCE PORT SIZES OR DEAD HEAD PUMP



WARNING! DO NOT USE WITH FLAMMABLE LIQUIDS

# CENTRIFUGAL PUMPS

2" STAINLESS STEEL PUMPS WITH ELECTRIC MOTORS

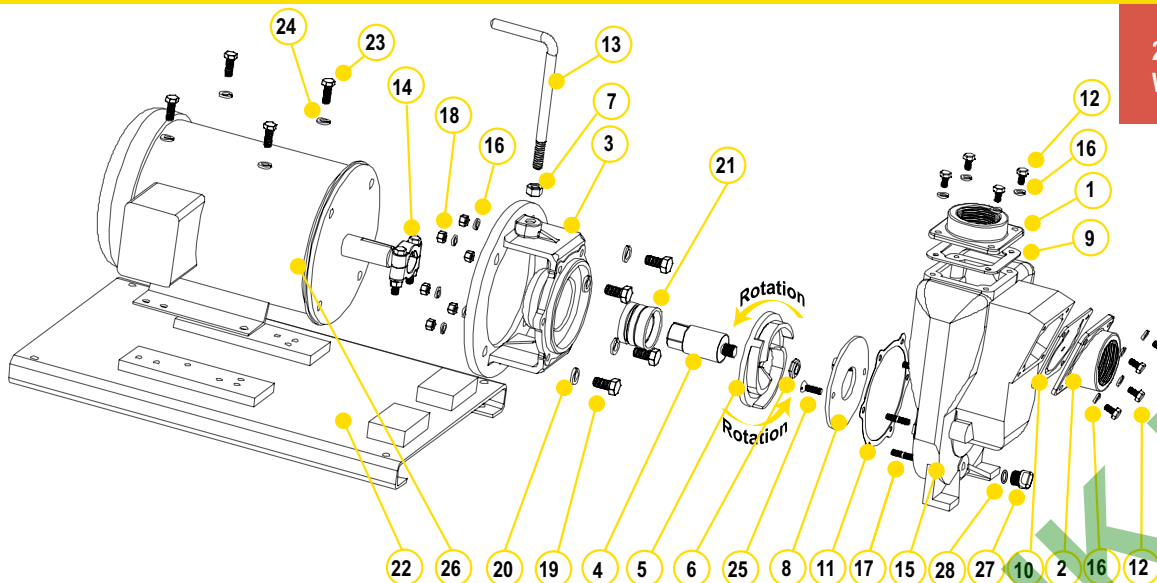

## REPLACEMENT PARTS 2" STAINLESS STEEL PUMPS

ITEM	PART NO	DESCRIPTION	QTY
1	17000SS	2" NPT OUTLET FLANGE	1
2	17002SS	2" NPT INLET FLANGE	1
3	17046SS	C-FACE ADAPTER (234PE3SS)	1
3	17446SS	C-FACE ADAPTER (234PE5SS & 234PE51SS)	1
4	17007	IMPELLER SHAFT (234PE3SS)	1
4	17406	IMPELLER SHAFT (234PE5SS & 234PE51SS)	1
5	17408SS	IMPELLER	1
6	17009B	5/8" IMPELLER NUT	1
7	17010	1/2" HEX NUT	1
8	17011SS	WEAR PLATE	1
9	17014	FKM OUTLET GASKET	1
10	17017	FKM GASKET & CHECK VALVE	1
11	17018	ADAPTER GASKET	1
12	17019	BOLT	8
13	15022	HANDLE	1
14	17024	CLAMP ASSEMBLY W/KEY (234PE3SS)	1
15	17026SS	PUMP HOUSING	1
15	17026SS	PUMP HOUSING (234PE5SS & 234PE51SS)	1
16	V10118	5/16" LOCK WASHER	20
17	17042	HOUSING STUD	6
18	V10119	HEX NUT	8
19	N/A	BOLT	4
20	N/A	WASHER	4
21	17035SS	SEAL ASSEMBLY (234PE3SS)	1
21	18025SS	SEAL ASSEMBLY (234PE5SS & 234PE51SS)	1
22	17701	BASE PLATE ASSEMBLY	1
23	17704	BOLT	4
24	V20018	3/8" LOCK WASHER	4
25	17130SS	5/16-18 X 1.00" FHSCS, 316 SS	2
26	N/A	ELECTRIC MOTOR	1
27	12777SS	1/2" STAINLESS STEEL PLUG	1
28	UV15163V	FKM O-RING	1

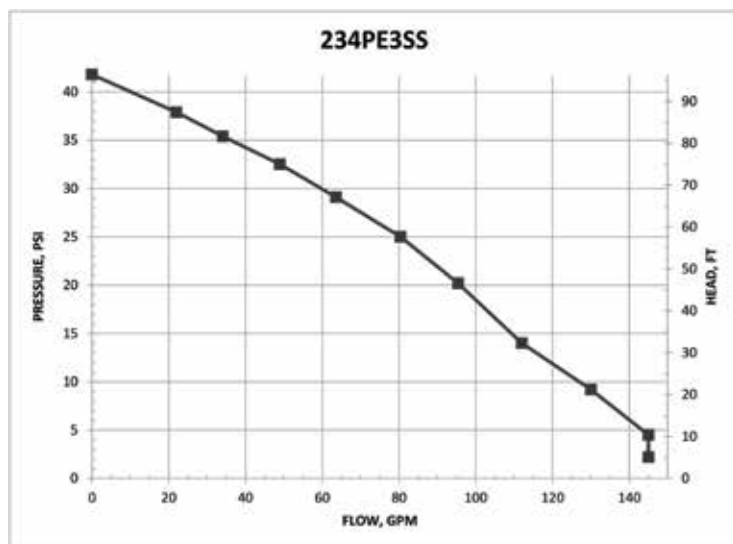

# CENTRIFUGAL PUMPS

## 2" STAINLESS STEEL PUMPS WITH HYDRAULIC MOTORS

### FEATURES

- Cast iron construction for rugged dependable service
- Stainless steel hardware
- Replaceable inlet and outlet flanges
- Dynamically balanced impeller
- Hydraulic fluid capacity is minimum 6 gallons and maximum 10 gallons
- Open or closed system
- 12 HP motor
- Recommendation to use the motor spool control valve or a suitable equivalent. The lack of such a valve in this circuit may cause failure to the hydraulic motor.



### 2" STAINLESS STEEL PUMPS W/ HYDRAULIC MOTORS

PART NO	DESCRIPTION	HP	QTY
200PHYSS	2" STAINLESS STEEL PUMP W/ 12 HP HYDRAULIC MOTOR	12	1

### SPOOL VALVE ASSEMBLY DIAGRAM

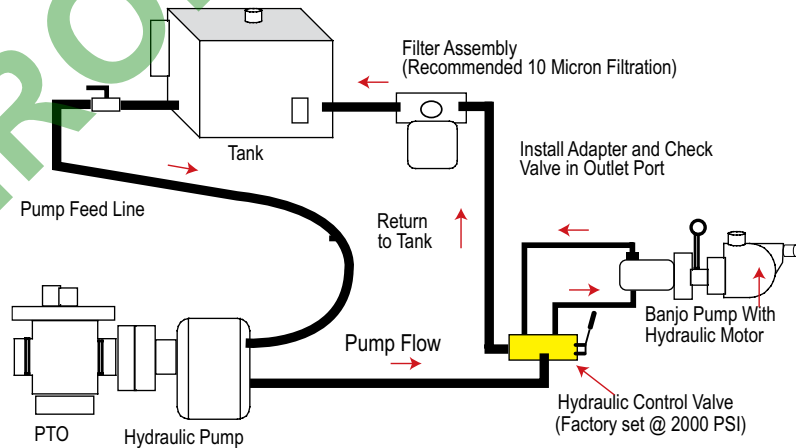

**WARNING! DO NOT RUN PUMP DRY, RESTRICT OR REDUCE PORT SIZES OR DEAD HEAD PUMP**



**WARNING! DO NOT USE WITH FLAMMABLE LIQUIDS**



### HYDRAULIC MOTOR SPOOL VALVE

PART NO	DESCRIPTION	HP	QTY
HSV1000	HYDRAULIC MOTOR SPOOL VALVE	N/A	1

# CENTRIFUGAL PUMPS

2" STAINLESS STEEL PUMPS WITH HYDRAULIC MOTORS

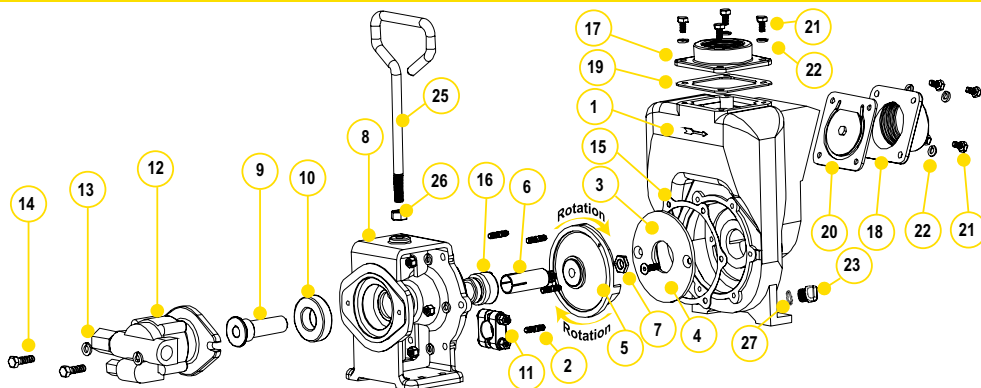

## REPLACEMENT PARTS 2" STAINLESS STEEL PUMPS

ITEM	PART NO	DESCRIPTION	QTY
1	17026SS	PUMP HOUSING	1
2	17042	PUMP HOUSING STUD	6
3	17011SS	WEAR PLATE	1
4	17130SS	5/16-18 X 1.00" FHSCS, 316 SS	2
5	17008SS	5" IMPELLER	1
6	17007	7/8" SLEEVE DRIVE FOR ELECTRIC MOTOR	1
7	17009B	5/8" IMPELLER NUT	1
8	N/A	HYDRAULIC ADAPTER	1
9	17055A	HYDRAULIC ADAPTER SHAFT	1
10	17056	SKF 6206-2RS1 BEARING	1
11	17024	7/8" CLAMP, NO KEY	1
12	HY1013	MGG20025BC1D3 HYDRAULIC MOTOR ASSEMBLY	1
13	V20018	3/8" LOCK WASHER	2
14	18010SS	3/8" - 16 X 1.25" HHHCS	2
15	17018	GASKET ADAPTER	1
16	17035SS	FKM SEAL ASSEMBLY	1
17	17000SS	2" NPT OUTLET FLANGE	1
18	17002SS	2" NPT INLET FLANGE	1
19	17014	FKM GASKET	1
20	17017	GASKET CHECK VALVE ASSEMBLY	1
21	17019	5/16" - 18 X 0.75" CAP SCREW	8
22	V10118	5/16" SPLIT LOCK WASHER	14
23	12777SS	1/2" STAINLESS STEEL PLUG	1
24	V10119	5/16" - 18 HEX NUT	6
25	15022	HANDLE	1
26	17010	1/2" HEX NUT -13UNF-RH	1
27	UV15163V	O-RING FKM	1

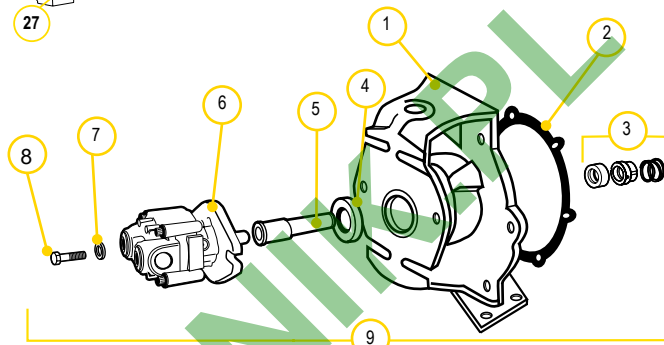

## HYDRAULIC MOTOR DATA

U.S. GALLONS/REV.	0.0025
CUBIC INCHES/REV.	0.580
LITERS/REV.	0.0097
MAX HYDRAULIC PRESSURE	2000 PSI
MIN HYDRAULIC PRESSURE	200 PSI
INLET PORT	SAE 10 (7/8-14 UNF-2B)
OUTLET PORT	SAE 10 (7/8-14 UNF-2B)
MINIMUM GPM REQUIRED	6 GPM 2400 RPM
MAXIMUM GPM REQUIRED	10 GPM 4000 RPM
IDEAL GPM REQUIRED	9 GPM 3600 RPM

## CONNECTION INFORMATION

INLET	"A" PORT
OUTLET	"B" PORT
SUPPLIED CHECK VALVE IS TO ENSURE PROPER ROTATION OF THE BANJO PUMP. PLACE CHECK VALVE IN OUTLET PORT (MARKED "B") FOR PROPER RIGHT HAND ROTATION.	

## SPOOL VALVE INFORMATION

REQUIRED OUTLET FLOW	MIN 6 GPM / MAX 10 GPM
REQUIRED SYSTEM PRESSURE	MIN 500 PSI / MAX 2000 PSI

## REPLACEMENT PARTS 2" HYDRAULIC ADAPTER

ITEM	PART NO	DESCRIPTION	QTY
1	N/A	SS HYDRAULIC MOTOR ADAPTER	1
2	17018	GASKET ADAPTER	1
3	17035SS	SEAL ASSEMBLY	1
N/S	17007	7/8" SS SHAFT SLEEVE	1
4	17056	SKF 6206-2RS1 BEARING	1
5	17055A	HYDRAULIC ADAPTER SHAFT	1
6	HY1013	GRESEN® HYDRAULIC MOTOR	1
7	V20018	LOCK WASHER	2
8	18010SS	BOLT	2

200PHYSS

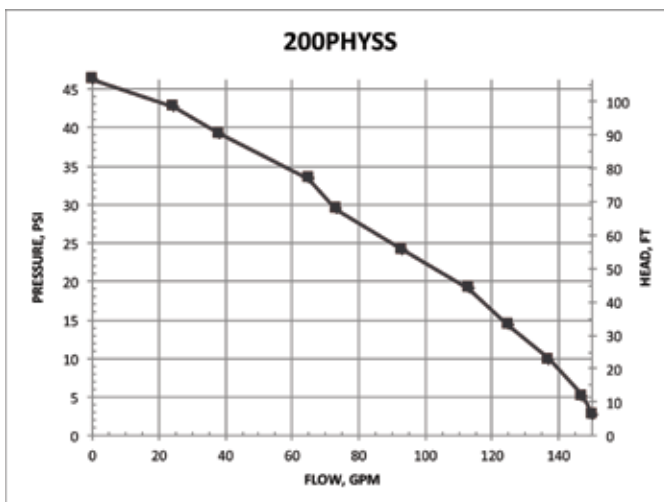

# CENTRIFUGAL PUMPS

## 3" STAINLESS STEEL PUMPS

### FEATURES

- 316 stainless steel housing and wettable internal components including impeller, sleeve, wear plate and fasteners
- Carbon ceramic seal with 316 stainless steel cup and spring with FKM elastomer
- Replaceable inlet and outlet flanges
- Dynamically balanced impeller
- Pump only packs complete and ready for attachment to gasoline engine
- Pedestal pump for long coupling to electric motor
- Recommendation for  $\frac{5}{8}$ " shaft: 56C frame size, 3 HP, 3450 RPM & 5" max impeller for close coupling to electric motors
- Recommendation for  $\frac{7}{8}$ " shaft: 145TC frame size, 3 HP, 3450 RPM & 5" max impeller for close coupling to electric motors
- Engine warranty service available at authorized dealers
- Due to weight and size of pumps, Banjo ships these by truck only.



### 3" STAINLESS STEEL PUMPS W/GAS ENGINES

PART NO	DESCRIPTION	HP	QTY
300PH13SS	3" SS PUMP W/13 HP HONDA® ENGINE W/ELECTRIC START & PULL ROPE	13	1

### 3" STAINLESS STEEL PUMP ONLY

PART NO	DESCRIPTION	HP	QTY
300PO-SS	3" SS PUMP ONLY W/ 1" SHAFT SLEEVE	N/A	1

### 3" STAINLESS STEEL BEARING PEDESTAL

PART NO	DESCRIPTION	HP	QTY
300PB-SS	3" SS BEARING PEDESTAL W/ 1" STRAIGHT SHAFT	N/A	1

### 3" STAINLESS STEEL PUMPS W/ HYDRAULIC MOTOR

PART NO	DESCRIPTION	HP	QTY
300PHYSS	3" STAINLESS STEEL PUMP W/ 12 HP HYDRAULIC MOTOR	12	1



**WARNING! DO NOT RUN PUMP DRY, RESTRICT OR REDUCE PORT SIZES OR DEAD HEAD PUMP**



**WARNING! DO NOT USE WITH FLAMMABLE LIQUIDS**



# CENTRIFUGAL PUMPS

## 3" STAINLESS STEEL PUMPS

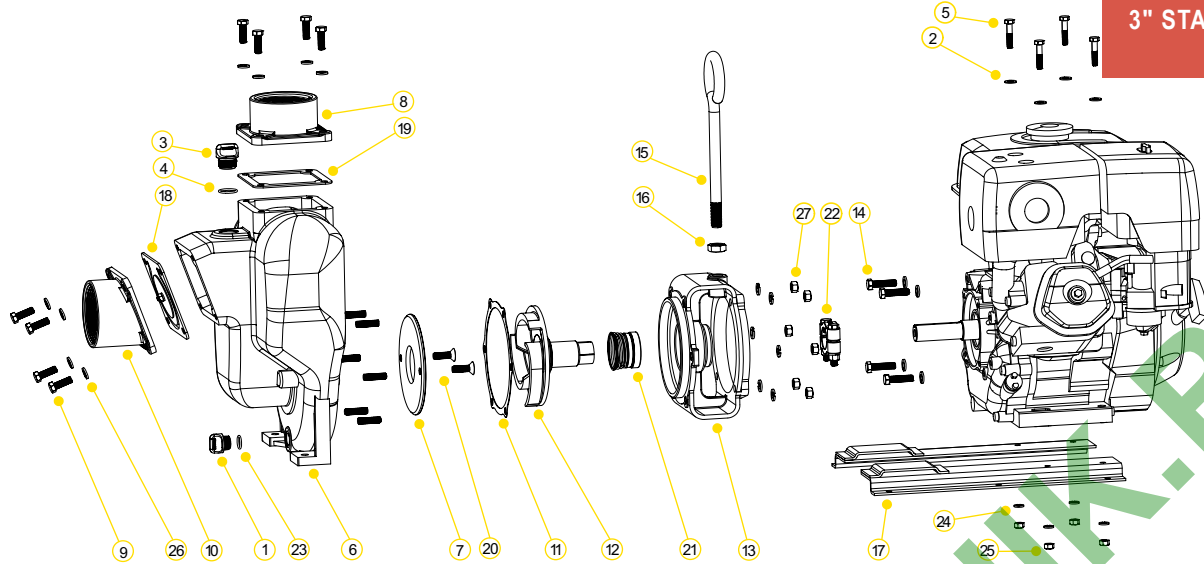

### REPLACEMENT PARTS 3" STAINLESS STEEL PUMPS

ITEM	PART NO	DESCRIPTION	QTY
1	12777SS	½" STAINLESS STEEL PLUG	1
2	12901	SS REAR BRACKET WASHER	4
3	13777SS	¾" STAINLESS STEEL PLUG	1
4	13778V	O-RING FKM	1
5	N/A	⅝" - 18 X 1¼" ZINC PLATED	4
6	18001SS	SS PUMP HOUSING	1
7	18004SS	SS WEAR PLATE	1
8	N/A	3" NPT OUTLET FLANGE	1
9	18010SS	⅜" - 16 X 1½" 8" SS CAP SCREW HXHD	8
10	N/A	3" NPT INLET FLANGE	1
11	18021	ADAPTER GASKET	1
12	18023SS	1" SS IMPELLER & DRIVE SHAFT FOR GAS ENGINE	1
12	N/A	1¼" SS IMPELLER & DRIVE SHAFT FOR ELECTRIC MOTOR (300PO-SSCF)	1
13	18026SS	ADAPTER FOR GAS ENGINE	1
13	N/A	ADAPTER FOR ELECTRIC MOTOR (300PO-SSCF)	1
14	18027	⅜" - 16 X 1½" HHCS	4
15	18033	HANDLE	1
16	18034	⅝" SS JAM NUT	1
17	18035	Z RAILS	1
18	18042	FKM GASKET CHECKVALVE ASSEMBLY	1
19	18044	FKM OUTLET GASKET	1
20	18106SS	WEAR PLATE FLAT HEAD SCREW	2
21	18025SS	FKM SEAL ASSEMBLY	1
22	18129	CLAMP ASSEMBLY	1
23	UV15163V	O-RING FKM	1
24	V10118	⅝" LOCK WASHER	4
25	V10119	⅝" - 18 SS HEX NUT	4
26	V20018	⅜" SS LOCK WASHER	18
27	V20019	⅜" 16 SS HEX NUT	6
KIT	18100SS	REPAIR KIT (CONSIST OF ITEMS 7, 11, 12, 20 & 21)	1

### KITS 3" STAINLESS STEEL PUMPS

PART NO	FKM REPAIR KIT NO	FKM SEAL KIT NO
300PH13SS	18100SS	18025SS
300PB-SS	18100SS	18025SS
300PO-SS	18100SS	18025SS

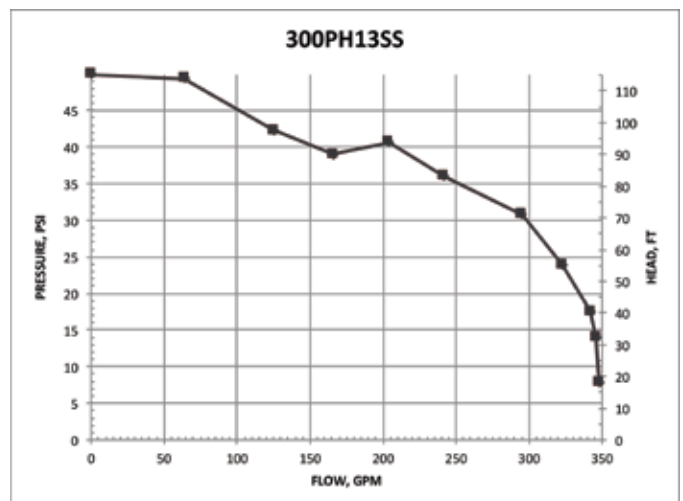

**Note:** Please see repair parts list for 300PHYSS on our website.

# REFERENCE

## ENGINE/MOTOR REFERENCE

- Engine warranty service contact information:
- Briggs and Stratton® phone: 414-259-5262 www.briggsandstratton.com
- Honda® phone: 800-426-7701 www.honda.com

### BRIGGS & STRATTON® ENGINES

BANJO PART NO	E3	E6.5PRO	E6.5PROE	E11PROE
MANUFACTURER	BRIGGS & STRATTON®	BRIGGS & STRATTON®	BRIGGS & STRATTON®	BRIGGS & STRATTON®
MODEL NO	083132-1110-F1	130G32-0122-F1	130G37-0136-F1	19N137-0076-F1
RATED HP	3.5 HP @ 3600 RPM	6.5 HP @ 3600	6.5 HP @ 3600 RPM	11 HP @ 3600
RATED TORQUE	4.9 FT-LBS @ 2800 RPM	9 FT-LBS @ 2800 RPM		15.50 FT-LBS @ 2800 RPM
SHAFT SIZE	3/4" DIAMETER W/ 3/16" KEY WAY	3/4" DIAMETER W/ 3/16" KEY WAY	3/4" X 2 27/64", 3/16" KEY WAY	3/4" DIAMETER W/ 3/16" KEY WAY
SHAFT ID THREAD	5/16"-24 UNF 2B	5/16"-24 UNF 2B	5/16"-24 UNF	5/16"-24 UNF 2B
ENGINE OIL REQUIRED	SYNTHETIC 5W30	ABOVE 40°F: 30W BELOW 40°F: 5W30	ABOVE 40°F: 30W BELOW 40°F: 5W30	SYNTHETIC 10W30
ENGINE OIL CAPACITY	21 OZ	20 OZ	20.0 OZ	28 OZ
FUEL REQUIRED	77	77	87	77
FUEL TANK CAPACITY	.50 GALLON	1 GALLON	0.825	1 GALLON
OIL ALERT	N	N	Y	N
ELECTRIC START	N	N	Y	N
OVER HEAD VALVE	N	N	Y	N

### HONDA® ENGINES

BANJO PART NO	E5H	E5HE	E6H	E8H	E13H	E24H
MANUFACTURER	HONDA®	HONDA®	HONDA®	HONDA®	HONDA®	HONDA®
MODEL NO	GX160	GX160	GX200	GX240	GX390	GX690RHTAF
RATED HP	5.4 HP @ 3600	5.4 HP @ 3600	6.4 HP @ 3600	8.0 HP @ 3600	13.0 HP @ 3600	22.1 HP @ 3600 RPM
RATED TORQUE	8.0 FT-LBS @ 2500 RPM	8.0 FT-LBS @ 2500 RPM	7.76 FT-LBS @ 2600 RPM	12.3 FT-LBS @ 2500 RPM	19.5 FT-LBS @ 2500 RPM	35.6 FT-LB @ 2500 RPM
SHAFT SIZE	3/4" DIAMETER W/ 3/16" KEY WAY	3/4" DIAMETER W/ 3/16" KEY WAY	3/4" DIAMETER W/ 3/16" KEY WAY	1" DIAMETER W/ 1/4" KEY WAY	1" DIAMETER W/ 1/4" KEY WAY	1 1/8" X 4", 1/4" KEY WAY
SHAFT ID THREAD	5/16"-24 UNF 2B	5/16"-24 UNF 2B	5/16"-24 UNF 2B	3/8"-24 UNF 2B	3/8"-24 UNF 2B	7/16" - 20 UNF-2B
ENGINE OIL REQUIRED	10W30	10W30	10W30	10W30	10W30	10W30
ENGINE OIL CAPACITY	.63 QT	.63 QT	.63 QT	1.16 QT	1.16 QT	2.1 QT
FUEL REQUIRED	86	86	86	86	86	86
FUEL TANK CAPACITY	.95 GALLON	.95 GALLON	.95 GALLON	1.59 GALLON	1.72 GALLON	N/A
OIL ALERT	Y	Y	Y	Y	Y	Y
ELECTRIC START	N	Y	N	Y	Y	Y
OVER HEAD VALVE	Y	Y	Y	Y	Y	Y

### ELECTRIC MOTORS

BANJO PART NO	BEM5	BEM15	BEM51	BEM5-182CZ	BEM51-182CZ
MANUFACTURER	BALDOR®	BALDOR®	BALDOR®	BALDOR®	BALDOR®
MODEL NO	CEM3613T	37-0000-0002	CL3608TM	CL308TM	36K302T860G1
RATED HP	5 HP	15 HP	5 HP	5HP	5HP
SHAFT SIZE	1 1/8"	1 3/8"	1 1/8"	3/4"	3/4"
DESCRIPTION	TEFC	TEFC	TEFC	TEFC	TEFC
PHASE	3	3	1	3	1
RPM @ 60 HZ	3450	3450	3600	3600	3600
NEMA FRAME SIZE	184TC	215TC	184TC	182CZ	182CZ
VOLTAGE	230/460	230/460	230	230/460	230
EFF@FULL LOAD	88.5	91	83	90.2	84

BRITISH PIPE THREAD		
PART NO	DESCRIPTION	PAGE NO
DM100ABSS	1" STAINLESS STEEL MALE DRY MATE WITH BSP & ALL PTFE SEALS	56
DM100DBSS	1" STAINLESS STEEL FEMALE DRY MATE WITH BSP & FKM FACE SEAL	56
DM150AB	1½" POLY MALE DRY MATE WITH BSP & FKM FACE SEAL	52
DM150ABSS	1½" STAINLESS STEEL MALE DRY MATE WITH BSP & ALL PTFE SEALS	57
DM150DB	1½" POLY FEMALE DRY MATE WITH BSP	52
DM150DBSS	1½" STAINLESS STEEL FEMALE DRY MATE WITH BSP & FKM FACE SEAL	57
DM200AB	2" POLY MALE DRY MATE WITH BSP & FKM FACE SEAL	53
DM200ABSS	2" STAINLESS STEEL MALE DRY MATE WITH BSP	58
DM200DB	2" POLY FEMALE DRY MATE WITH BSP & FKM FACE SEAL	53
DM200DBSS	2" STAINLESS STEEL FEMALE DRY MATE WITH BSP & FKM FACE SEAL	58
DM220ABSS	2" MALE X BSP THREADS W/PTFE SEALS	59
DM220DBSS	2" FP FEMALE X BSP THREADS	59
NIP2101	2" NPT X BSP WHITE	62

WWW.ROLTRONIK.PL

# REFERENCE

PART NO	PAGE NO(S)	WEIGHT	PART NO	PAGE NO(S)	WEIGHT	PART NO	PAGE NO(S)	WEIGHT
12046	101, 131	0.5	15772	129, 131, 141	1.75	17024	121, 125, 127, 147, 149, 151	0.128
12052	101	N/A	15999	129, 131	0.282	17026	121, 125, 127	21.23
12099	101, 111, 113, 129, 131, 97	0.066	16000	145	6.424	17028	121	0.16
12155	107, 109, 117, 119, 99	1.186	16001	139	4.808	17032	123	0.036
12705	101, 103, 105, 107, 109, 111, 113, 115, 117, 119, 129, 131, 141, 143, 97, 99	0.258	16002	145	5.59	17033	121, 129	3.018
12709	107, 109, 117, 119, 141, 143, 99	0.001	16003	139	5.688	17035	121, 125, 127	0.18
12710	101, 103, 105, 111, 113, 115, 129, 131, 97	0.01	16011	139, 145	0.098	17040	121, 147	0.028
12713	101, 103, 105, 111, 113, 115, 97	0.11	16019	139, 145	0.068	17042	121, 125, 147, 149, 151	0.02
12716	105, 111, 113, 129, 97	0.02	16099	139, 145	0.25	17046	121, 125	7.572
12717	101, 103, 105, 107, 109, 111, 113, 115, 117, 119, 129, 131, 141, 143, 97, 99	0.001	16702	139, 145	11	17056	115, 127, 151	0.462
12720	101, 103, 105, 107, 109, 111, 113, 115, 117, 119, 97, 99	0.032	16704	139	41.5	17100	121	4
12723	89	0.006	16706	139, 145	0.888	17123	121, 123, 147	0.384
12724	89	0.001	16707	145	4	17130	121, 123, 125	0.022
12725	101, 103, 105, 107, 109, 111, 113, 115, 117, 119, 97, 99	0.002	16710	139	0.002	17202	123	3.738
12754	101, 103, 105, 107, 109, 111, 113, 115, 117, 119, 97, 99	0.002	16712	145	58	17208	123	1.802
12756	101, 131	1.438	16713	139	0.2	17226	123	25.21
12766	107, 109, 119, 99	0.076	16733	139	55	17235	123	0.35
12772	101, 103, 105, 107, 109, 97, 99	0.211	16751	139, 145	0.024	17242	123	0.032
12777	101, 103, 107, 109, 117, 119, 121, 123, 125, 127, 133, 135, 137, 141, 143, 47, 85, 89, 97, 99	0.017	16752	139, 145	0.004	17406	125, 149	0.638
12900	101, 103, 105, 107, 109, 111, 113, 115, 117, 119, 97, 99	0.008	16765	139, 145	0.098	17408	125	2
12901	101, 103, 105, 111, 113, 115, 129, 131, 141, 143, 153, 97	0.004	16773	139	3.452	17446	125	18
13034	107, 109, 117, 119, 141, 99	N/A	16774	139	2.75	17701	101, 125, 131, 149	29.5
13055	117, 141, 143	0.674	16775	145	4.242	17704	101, 125, 131, 133, 135, 139, 145, 149	0.046
13702	111, 113, 115, 117, 119	1.479	16901	117, 119, 139, 141, 143, 145	0.01	18001	133, 135, 137	65.65
13712	111, 115, 117	4.018	17000	121, 123, 125, 129	1.528	18004	133, 135, 137	1.628
13719	107, 109, 117, 119, 141, 143, 99	0.012	17001	121	1.472	18008	133, 135, 137	3.802
13765	111, 113, 139	0.05	17002	121, 123, 125	1.888	18009	133, 135, 137	0.036
13766	117, 141	0.084	17003	121	1.926	18012	133, 135, 137	3.906
13771	111, 113, 115, 117	0.204	17004	121	6.19	18013	133, 135, 137	0.53
13772	111, 113, 117, 119	0.222	17005	121, 147	0.376	18021	133, 135, 137, 153	0.012
13777	111, 113, 115, 129, 131, 133, 135, 137, 139, 141, 143, 145, 49, 93	0.025	17006	121, 147	0.25	18023	133, 137	4.35
13778	111, 113, 115, 129, 131, 133, 135, 137, 139, 141, 143, 145, 49, 93	0.002	17007	121, 125, 127, 147, 149, 151	0.216	18025	125, 133, 137	0.39
13999	111, 113, 115	0.266	17008	121, 125, 127	2	18026	133	9.91
15000	129, 131	2.244	17010	121, 123, 125, 127, 129, 131, 137, 147, 149, 151	0.036	18027	139, 145, 153	0.056
15022	121, 123, 125, 127, 129, 131, 147, 149, 151	1.124	17011	121, 123, 125	0.866	18029	133, 137	0.63
15025	139	N/A	17013	121, 123, 125, 129	0.034	18033	133, 135, 137, 139, 141, 143, 145, 153	1.236
15035	109, 117	0.35	17014	147, 149, 151	0.042	18034	133, 135, 137, 139, 141, 143, 145, 153	0.048
15702	129, 131	9.086	17016	121, 123, 125	0.214	18035	133, 153	2.73
15703	129, 131	14.978	17017	147, 149, 151	0.262	18042	153	0.584
15712	129, 131	26.082	17018	121, 123, 125, 127, 147, 149, 151	0.01	18044	153	0.056
15751	111, 113, 129, 131	0.014	17019	121, 123, 125, 129, 147, 149, 151	0.024	18048	133	12.788
15752	129, 131	0.002	17023	121, 147	0.386	18049	133, 137	20.516

PART NO	PAGE NO(S)	WEIGHT	PART NO	PAGE NO(S)	WEIGHT	PART NO	PAGE NO(S)	WEIGHT
18055	133, 137	0.834	12202W	107, 109, 117, 119, 99	1.464	15035E	107, 117, 119, 135, 141, 143, 99	0.386
18056	137	0.1	125A	71	0.098	150A	71	0.18
18100	133, 137	7.2	125B	71	0.3	150A90	74	0.306
18106	133, 135, 137	0.04	125C	71	0.29	150B	71	0.57
18129	125, 133, 135, 153	0.64	125D	71	0.31	150C	71	0.57
18206	135	4.8	125E	71	0.11	150C90	74	0.62
18218	133, 135, 137	1.436	125F	71	0.98	150CAP	71	0.54
18435	145	1	12600B	103, 115, 129	14	150D	71	0.59
18500	133, 135, 139	13	12702A	101, 103, 105, 107, 109, 97, 99	1.205	150D90	74	0.65
18502	133, 137, 143	0.802	12703A	101, 103, 105, 111, 113, 115, 97	2.369	150E	71	0.21
18504	133	1.928	12703AW	117	2.792	150F	71	0.21
18511	139	3.404	12705V	101, 117, 97	0.24	150F90	74	0.266
18512	139	0.036	12707W	107, 109, 119, 99	2.788	150G	45, 67, 73	0.015
18600	137	N/A	12709V	117	0.001	150GV	45, 67, 73	0.3
18700	95	1.728	12710V	101, 97	0.01	150PL	71	0.16
19702	141, 143	9.262	12712A	101, 103, 97, 99	3.25	150POICF5/8-4.1	120	47
19766	143	0.1	12713V	101, 129, 131, 97	0.12	150RING	73	0.026
050C	70	0.14	12715A	103, 105, 111, 113, 115, 129, 131, 141, 143, 97	0.046	15999V	129, 131	0.288
050D	70	0.16	12717V	101, 117, 97	0.01	16704A	139	41.5
050E	70	0.05	12719A	101, 103, 105, 107, 109, 111, 113, 115, 119, 129, 131, 141, 143, 97, 99	0.046	17000SS	147, 149, 151	1.58
050F	70	0.06	12719AV	101, 97	0.05	17002SS	147, 149, 151	2.038
075C	71	0.15	12754V	101, 117, 97	0.01	17008-4.1	121	1.534
075CAP	70, 71, 72	0.13	12765A	101, 103, 105, 111, 113, 115, 129, 131, 97	0.05	17008SS	147, 151	2
075D	71	0.15	12771A	105, 97	0.218	17009B	121, 123, 125, 127, 147, 149, 151	0.022
075E	71	0.06	12775A	101, 103, 105, 107, 109, 111, 113, 115, 117, 97, 99	0.014	17011SS	147, 149, 151	0.888
075F	71	0.06	12777SS	147, 149, 151, 153	0.14	17026SS	147, 149, 151	32
100125CAP	71	0.27	12882A	111, 113, 121, 123, 129, 147, 97	7.6	17035SD	121	0.13
100125PL	71	0.06	12883B	121	0.146	17035SS	147, 149, 151	0.18
100A	71	0.09	12902A	101, 103, 105, 107, 109, 111, 113, 115, 117, 119, 129, 131, 141, 143, 97, 99	0.006	17046SS	147, 149	8.804
100B	71	0.29	12999A	101, 103, 105, 97	0.25	17055A	127, 151	1.75
100C	71	0.27	12999AV	101, 105, 97	0.32	17056E	103, 109	2
100D	71	0.31	13719V	117	0.019	17100SS	147	3.384
100E	71	0.1	13777SS	153	0.205	17130SS	147, 149, 151	0.02
100F	71	0.11	13778V	153	0.002	17201A	123	8.736
100G	67, 73	0.2	150(200)K	73	0.134	17206A	123	0.628
100GV	67, 73	0.02	15000V	129, 131	2.364	17408SS	149	2.106
100RING	73	0.012	150125A	71	0.197	17446SS	149	10.818
12000A	101, 103, 105, 111, 113, 115, 97, 99	0.75	150125B	71	0.26	18001SS	153	57.5
12000AV	101, 105, 97, 99	0.9	150125C	71, 72	0.568	18004SS	153	1.616
12049E	103, 109, 115	8.118	150125D	71	0.31	18010SS	103, 109, 115, 127, 133, 135, 137, 151, 153	0.044
12055E	103, 109	0.566	150125E	71	0.16	18023-1.125	133	4.322
12201W	117	1.458	150125F	71	0.18	18023SS	153	4.32

# REFERENCE

PART NO	PAGE NO(S)	WEIGHT	PART NO	PAGE NO(S)	WEIGHT	PART NO	PAGE NO(S)	WEIGHT
18025SD	133, 137	0.32	200PH5-SS	146	105	231MPT	64	0.074
18025SS	149	0.25	200PH-5V	96	48	234PE5SS	148	168
18026SS	153	10.11	200PH5W	98	53	234PIE5	124	160
18055H	143	0.75	200PH6	96	N/A	234PIE51	124	200
18100SS	153	7.5	200PHA	102	25	234POI	124	N/A
18106SS	153	0.04	200PHAW	102	25	234PPE5	100	135
18125SS	153	0.248	200PHY	102	21.308	234PPE51	100	145.5
18200A	135	31.6	200PHYSS	150	52	234PPE51V	100	145
18202A	135	4.918	200PI-3	120	81	234PPE5V	100	123
18203A	135	4.92	200PI6PRO	120	81.5	250CAP	72	0.68
19001H	143	10.7	200PIH-5	120	81.5	300A	72	0.48
19201W	141, 143	10	200PIH5E	120	N/A	300B	72	1.17
19703W	141, 143	17.006	200PKL	73	0.02	300C	72	1.4
19772SS	141, 143	N/A	200PL	72	0.21	300CAP	72	1.07
200150C	72	0.66	200PO	96	7.286	300D	72	1.19
200A	72	0.3	200POI	120	52.5	300E	72	0.78
200A90	74	0.46	200POICF5/8	120	47	300F	72	0.57
200B	72	0.64	200PO-SS	146	47	300F200F	73	0.608
200B90	74	0.948	200POSSCF5/8	146	47	300FF	73	0.643
200C	72	0.69	200PO-V	96	10	300G	45, 67, 73	0.04
200C90	74	0.78	200SBS	95	0.25	300GV	45, 67, 73	0.06
200CAP	64, 72	0.6	201B	72	0.71	300K	73	0.23
200CAPSH	64, 72	0.52	201CAPSH	64	0.566	300P	73	0.036
200D	72	0.66	201FPT	64	0.04	300P11PRO	110	81
200D90	74	0.88	201PBIW	122	58	300P11PROW	116	67
200E	72	0.32	201PIH5W	122	94	300PB	110	20
200F	72	0.31	201POIW	122	59	300PBI	132	125
200F45	74	0.346	202CAP	64	0.34	300PB-SS	152	99
200F90	74	0.434	205PB	96	16	300PBW	116	26
200FF	73	0.33	205PB-V	96	16	300PH13SS	152	150
200G	45, 73	0.02	205PO	96	9	300PH13W	116	103
200GV	45, 73	0.03	205PO-V	96	9	300PH-6	110	50
200KL	73	0.18	205POW	4, 98	8.5	300PH6W	116	56
200P	73	0.17	211FPT	64	0.03	300PHY	114	26
200P6PRO	96	50	222PBI	128	70	300PHYSS	152	140
200P6PROE	96	N/A	222PI6PRO	128	100	300PHYW	114	N/A
200P6PROV	96	51	222PIE5	130	180	300PIH13	132	176
200PB	96	15.786	222PIE51	130	190	300PIH-8	132	166
200PBI	120	48	222PIH5	128	82	300PIHY	136	140
200PB-SS	146	52	222PIH5E	128	110	300PL	72	0.43
200PH-5	96	51	222PIH6	128	110	300PO	110	12.005
200PH-5E	96	N/A	222POI	128	60	300POI	132	106

PART NO	PAGE NO(S)	WEIGHT	PART NO	PAGE NO(S)	WEIGHT	PART NO	PAGE NO(S)	WEIGHT
300PO-SS	152	115	AF200G	69	0.17	CAP200	78	0.25
300POW	116	15.3	AF200GV	69	0.17	CAP300	78	0.589
300POW6	116	N/A	AF300	69	1.175	CPLG025	77	0.03
300SBS	95	0.25	AF300G	69	0.17	CPLG038	77	0.026
301PBIW	134	135	AF300GV	69	0.17	CPLG050	77	0.09
301PIH13W	134	N/A	AF400	69	1.587	CPLG075	77	0.11
301POIW	134	130	AF400G	69	0.45	CPLG100	77	0.13
303B	72	1.634	AF400GV	69	0.45	CPLG125	77	0.19
303B200A	72	1.554	AFB200	69	0.697	CPLG150	77	0.3
303C	72	1.74	AFB300	69	1.419	CPLG200	77	0.34
305PHAW	114	N/A	BEM5-182CZ	131	95	CPLG300	77	0.835
305PHYWV	114	N/A	BF075	65	0.82	CR050	78	0.13
333PBI	138	185	BF075BD	66	0.88	CR075	78	0.35
333PIE15	138	242	BF100	65	0.82	CR100	78	0.27
333PIH13	138	285	BF100BD	66	0.9	CR125	78	0.725
333POI	138	90	BF100GE	65, 66	0.07	CR150	78	0.57
400A	72	1.269	BF100GRE	66	0.01	CR200	78	0.743
400B	72	2.03	BF100GRV	66	0.01	CV050	16	0.27
400C	72	2.39	BF150	65	1.26	CV100	16	0.222
400CAP	72	1.44	BF150BD	66	1.32	CV100MT	16	0.17
400D	72	2.07	BF200	65	1.07	CV10175	107, 109, 117, 119, 141, 143, 99	0.2
400E	72	1.785	BF200BD	66	1.2	CV10175V	117	N/A
400F	72	1.419	BF200GE	65, 66	0.05	CV221	16	1
400G	73	0.06	BF200GFV	66	0.05	CV300	16	1.45
400PL	72	1.11	BF200GV	65, 66	0.05	CV301	16	1.518
444PIH24	144	345	BF200V	65	1.07	DB20153M	52, 53	0.157
444POI	144	120	BF220	65	1.45	DB20290	52, 53	0.004
75A1/2	70	0.07	BF220BD	66	1.5	DB20295	52, 53, 57, 58	N/A
75A1/4	70	0.08	BF220GE	65, 66	0.154	DB20295A	52, 53	N/A
75A3/4	71	0.05	BF220GV	65, 66	0.08	DM100ABSS	56	3.5
75B1/2	70	0.14	BF300	65	2.264	DM100ASS	56	3.5
75B3/4	71	0.14	BF300BD	66	2.42	DM100CAP	56	0.19
75G	73	0.1	BF300GE	65, 66	0.2	DM100DBSS	56	3.75
75PL	70, 71	0.05	BF300GFE	66	0.02	DM100DSS	56	3.75
A204	101, 103, 105, 107, 109, 111, 113, 115, 117, 119, 129, 131, 141, 143, 97, 99	N/A	BF300GFV	66	0.02	DM100DSSE	56	3.75
A204V	101, 117, 97	N/A	BF300GV	65, 66	0.1	DM100PL	56	0.234
AF100	69	0.304	CAP038	78	0.03	DM101SS	56	0.346
AF100G	69	0.06	CAP050	78	0.06	DM10294A	56	0.01
AF100GV	69	0.06	CAP075	78	0.052	DM10295A	56	0.006
AF150	69	0.429	CAP100	78	0.09	DM10296	56	0.1
AF150G	69	0.08	CAP125	78	0.13	DM102SSV	56	0.386
AF200	69	0.656	CAP150	78	0.12	DM150A	52	2.64

# REFERENCE

PART NO	PAGE NO(S)	WEIGHT	PART NO	PAGE NO(S)	WEIGHT	PART NO	PAGE NO(S)	WEIGHT
DM150AB	52	2.2	DM25200	54	N/A	EVXR151	18	4.45
DM150ABSS	57	6.3	DM25294	59	N/A	EVXR201	19	N/A
DM150ASS	57	6.35	DM25294T	59	0.048	EVXR221	19	5.92
DM150D	52	2.64	DM300ACF	35	7.72	EVXR300	20	9.24
DM150DB	52	2.2	DM300AFP	55	4.8	FC100	45	0.25
DM150DBSS	57	6.9	DM300CAP	55	2.82	FC200	45	0.23
DM150DSS	57	6.9	DM300DCF	35	8.4	FC220	37, 45	0.25
DM150DSSE	57	6.9	DM300DFP	55	8.4	FC220B	45	1.364
DM200A	53	3.007	DM35153F	55	0.462	FC220TB	45	0.43
DM200AB	53	2.2	DM35153M	55	0.659	FC300	37, 45	0.34
DM200ABSS	58	5.768	DM35200	55	N/A	FC300B	45	1.76
DM200ACAP	57, 58	1	DMMT201A	53	2.5	FC300TB	45	0.52
DM200ACF	35	3.15	DPCF100	60	0.5	FM100	38	2.75
DM200AE	53	2.75	DPCM100	60	0.25	GHFT075A	75	0.06
DM200APL	57, 58	0.49	DPCMT100	60	0.27	GHFT075D	75	0.17
DM200ASS	58	6.2	EL025-90	79	0.016	GHFT075G	75	0.025
DM200CAP	52, 53	0.38	EL038-90	79	0.04	GHFT075MPT	75	0.04
DM200D	53	2.75	EL050-90	79	0.07	GHMT075B	75	0.14
DM200DB	53	2.2	EL075-90	79	0.1	GHMT075F	75	0.05
DM200DBSS	58	6.9	EL100-45	79	0.14	GHMT075FPT	75	0.04
DM200DCF	35	2.75	EL100-90	79	0.15	GHMT075MPT	75	0.04
DM200DE	53	3	EL125-90	79	0.22	GHN075	75	0.6
DM200DSS	58	6.9	EL150-90	79	0.33	H25053	5	0.28
DM200DSST	58	6.9	EL200-90	79	0.434	HB025	80	0.01
DM200PL	52, 53	0.49	EL300-90	79	1.194	HB025/038-90	80	0.01
DM20153F	52, 53	0.251	EVX071	18	3.82	HB025/050-90	80	0.022
DM20153M	52, 53	0.416	EVX100BL	21	4.313	HB025-038	80	0.012
DM201SS	57, 58	1.158	EVX100SL	21	4.313	HB025-038SS	80	0.07
DM20200A	52, 53	0.242	EVX101	18	3.892	HB025-050	80	0.48
DM20200D	52, 53	0.254	EVX121	18	3.832	HB025-050SS	80	0.07
DM20294A	52, 53, 57, 58	0.016	EVX151	18	N/A	HB025-90	80	0.01
DM20296	52, 53, 57, 58	0.125	EVX200	25	4.33	HB025SS	80	0.04
DM202SSV	57, 58	1.32	EVX200BL	21	4.876	HB038	80	0.01
DM220A	54	4.3	EVX200SL	21	4.876	HB038-050	80	0.02
DM220ABSS	59	0.43	EVX201	19	4.312	HB038-050SS	80	0.1
DM220CAP	54, 59	1	EVX220	25	4.92	HB038-90	80	0.02
DM220D	54	5.482	EVX220BL	21	6.253	HB038SS	80	0.09
DM220DBSS	59	7	EVX220SL	21	6.253	HB050	80	0.03
DM221PL	54	N/A	EVX221	19	5.052	HB050/038-90	80	0.024
DM221SS	59	0.206	EVX300	20	9.24	HB050/075-90	80	0.04
DM222SS	59	0.216	EVXR071	18	N/A	HB050-025	80	0.03
DM25153M	54	0.456	EVXR101	18	3.96	HB050-038	80	0.02



PART NO	PAGE NO(S)	WEIGHT	PART NO	PAGE NO(S)	WEIGHT	PART NO	PAGE NO(S)	WEIGHT
HB050-058SS	80	0.128	HB200-90	80	0.33	HY10131	109	N/A
HB050-075	80	0.03	HB200SS	80	1.13	HY10132	109	N/A
HB050-075SS	80	0.2	HB300	80	0.703	L200B	73	0.64
HB050-90	80	0.03	HB300-90	80	1.078	L200C	73	0.7
HB050SS	80	0.13	HB300SS	80	3.55	L200CAP	73	0.62
HB075	80	0.04	HB400	80	1.64	L200D	73	0.736
HB075/050-90	80	0.04	HBB20012590	79	0.25	LEV038	22	0.55
HB075/100-90	80	0.05	HBC050075	78	0.028	LEV038PL	22	0.08
HB075-038	80	0.03	HBEL100-90	79	0.06	LEV050	22	0.6
HB075-050	80	0.03	HBEL150/100-90	79	0.196	LS050-20	88	0.35
HB075-050SS	80	0.2	HBF075	80	0.06	LS050-40	88	0.35
HB075-058	80	0.038	HBF075-100	80	0.08	LS050-80	88	0.37
HB075-100	80	0.05	HBF075-90	80	0.06	LS050B/C1	89	0.298
HB075-100SS	80	0.25	HBF100	80	0.09	LS075-20	88	0.3
HB075-90	80	0.05	HBT038	81	0.03	LS075-40	88	0.33
HB075SS	80	0.2	HBT050	81	0.03	LS075-80	88	0.35
HB100	80	0.06	HBT050-075	81	0.03	LS075-B	89	0.194
HB100/075-90	80	0.06	HBT075	81	0.05	LS075B/C1	89	0.28
HB100/125-90	80	0.1	HBT075-050	81	0.04	LS075-G	89	0.004
HB100-075	80	0.06	HBT075-050SS	81	0.246	LS100-20	88	0.91
HB100-075SS	80	0.3	HBT075-100	81	0.06	LS100-40	88	0.9
HB100-125	80	0.08	HBT100	81	0.08	LS100-80	88	0.96
HB100-90	80	0.07	HBT100-075	81	0.06	LS100-B	89	0.639
HB100SS	80	0.3	HBT100-100	81	0.08	LS100B/C1	89	0.872
HB125	80	0.1	HBT150-100	81	0.218	LS100-C1	47, 89	0.232
HB125/100-90	80	0.09	HBT150-150	81	0.234	LS100-G	47, 89	0.02
HB125/150-90	80	0.09	HBT200	81	0.387	LS100-GV	89	0.02
HB125-075	80	0.08	HBT300	81	1.1609	LS120	47, 89	0.07
HB125-100	80	0.09	HM038	81	0.03	LS125-20	88	0.86
HB125-150	80	0.1	HM050	81	0.01	LS125-40	88	0.84
HB125-90	80	0.11	HM075	81	0.026	LS125-80	88	0.9
HB125SS	80	0.5	HM100	81	0.04	LS125-B	89	0.597
HB150	80	0.13	HM125	81	0.07	LS125B/C1	89	0.826
HB150/125-90	80	0.16	HM150	81	0.08	LS140	47, 89	0.07
HB150-100	80	0.09	HM200	81	0.22	LS150-06	90	2.42
HB150-125	80	0.1	HM300	81	0.762	LS150-12	90	2.42
HB150-200	80	0.19	HSV1000	102, 108, 114, 126, 136, 142, 150	11	LS150-120	90	2.5
HB150-90	80	0.23	HV200	36	0.58	LS150-20	90	2.42
HB150SS	80	0.68	HY1001	137	1.5	LS150-30	90	2.5
HB200	80	0.2	HY1003	103, 115	1.5	LS150-50	90	2.5
HB200/150-90	80	0.22	HY1012	137, 143	13.2	LS150-80	90	2.5
HB200-150	80	0.18	HY1013	103, 115, 151	4.5	LS150-B	91	1.38

# REFERENCE

PART NO	PAGE NO(S)	WEIGHT	PART NO	PAGE NO(S)	WEIGHT	PART NO	PAGE NO(S)	WEIGHT
LS150B/C	91	1.91	LSQ200-80	86	4.17	LST125-80	84	2.18
LS150-C	47, 91	0.576	LSQ200-B	87	1.787	LST125-H	85	1.18
LS150-G	47, 91	0.03	LSQ200-C	87	1.74	LST125-HB	85	1.846
LS150-GV	47, 91	0.03	LSQ200-G	87	0.05	LST130	47, 85	0.07
LS180	47, 89	2.12	LSQ200-PL	47, 49, 85, 87, 91	0.0418	LST150	47, 85	0.07
LS200-06	90	2.5	LSQ200-R	47, 49, 85	0.002	LST150-100	84	1.9
LS200-100	90	2	LSQ200R1	87	0.002	LST150-30	84	2.12
LS200-12	90	2.33	LSQ200-RV	87, 91	0.004	LST150-50	84	2.15
LS200-120	90	2	LSS300-BC	92, 93	23.88	LST150-80	84	2.13
LS200-20	90	2.33	LSS300-G	92, 93	0.1	LST150-B	47, 85	0.22
LS200-30	90	2.42	LSS300-GV	92, 93	0.044	LST150-G	47, 85	0.014
LS200-50	90	2.42	LSS300-H	93	1.724	LST150-GV	47, 85	0.024
LS200-80	90	2.42	LSS300-S	92, 93	0.032	LST150-HB	85	1.794
LS200-B	91	1.247	LSS300-SV	92, 93	0.05	LST15100	47, 85	0.27
LS200B/C	91	2	LSS306	93	0.198	LST1516	47, 85	0.196
LS206	47, 87, 91	0.3	LSS308	93	0.256	LST1530	47, 85	0.17
LS2100	91	0.09	LSS312	93	0.37	LST1550	47, 85	0.15
LS212	47, 87, 91	0.29	LSS320	93	0.4	LST1580	47, 85	0.1
LS2120	47, 87, 91	0.08	LSS330	93	0.368	LST180	47, 85	0.07
LS220	47, 87, 91	0.2	LSS350	93	0.366	LST200-10SS	86	16
LS230	47, 87, 91	0.188	LST075-100	84	0.83	LST200-50SS	86	16
LS250	47, 87, 91	0.13	LST075-16	84	0.824	LST200-B	87	1.946
LS250P	91	0.116	LST075-30	84	0.84	LST200-GV	87	0.04
LS280	47, 87, 91	0.1	LST075-50	84	0.84	LST200-HSS	87	1.614
LS300EC	49, 93	0.626	LST075-80	84	0.83	LST204SS	49, 87	0.416
LS304	49, 93	0.598	LST075-H	85	0.515	LST206SS	49, 87	0.382
LS308	49, 93	1.106	LST075-HB	85	0.738	LST208SS	49, 87	0.326
LS312	49, 93	4.31	LST100-100	84	0.76	LST2100SS	49	0.45
LS320	49, 93	1.03	LST100-16	84	0.78	LST210SS	49, 87	0.48
LS350	49, 93	0.92	LST100-30	84	0.79	LST216SS	49, 87	0.27
LS720	89	0.04	LST100-50	84	0.81	LST230SS	49, 87	0.49
LS740	89	0.04	LST100-80	84	0.78	LST250SS	49, 87	0.49
LS780	89	0.04	LST100-B	47, 85	2.17	LST280SS	49, 87	0.48
LSM300-04	92	8	LST100-G	47, 85	0.02	LST5100	83	0.016
LSM300-08	92	8	LST100-GV	47, 85	0.02	LST530	83	0.05
LSM300-12	92	8	LST100-H	85	0.471	LST550	83	0.024
LSM300-20	92	8	LST100-HB	85	2.25	LST580	83	0.02
LSM300-50	92	8	LST1100	47, 85	0.07	LSTM050-30	82	0.76
LSQ200-06	86	4.17	LST116	47, 85	0.084	LSTM050-30C	82	0.324
LSQ200-20	86	4.17	LST125-16	84	2.032	LSTM050-50	82	0.3
LSQ200-30	86	4.17	LST125-30	84	2.22	LSTM050-50C	82	0.76
LSQ200-50	86	4.17	LST125-50	84	2.24	LSTM050-80	82	0.76

PART NO	PAGE NO(S)	WEIGHT	PART NO	PAGE NO(S)	WEIGHT	PART NO	PAGE NO(S)	WEIGHT
LSTM050-80C	82	0.316	M100125BRB90	44	0.11	M200125MPTSS	42	0.2
LSTM050B	83	0.102	M100125BRBSWP90	39	0.149	M200150BRB	44	0.17
LSTM050BC	83	0.12	M100125MPT	42	0.114	M200150BRB45	44	0.17
LSTM050G	83	0.02	M100150BRB90	44	0.17	M200150BRB90	44	0.21
LSTM050H	83	0.176	M100A	43	0.07	M200150BRBSWP90	39	0.43
LSTM075-30	82	0.76	M100BRB	44	0.066	M200150FPT	42	0.343
LSTM075-30C	82	0.31	M100BRB45	44	0.074	M200150MPT	42	0.23
LSTM075-50	82	0.288	M100BRB90	44	0.08	M200150MPTSS	42	0.23
LSTM075-50C	82	0.308	M100BRBSWP90	39	0.144	M200A	43	0.24
LSTM075-80	82	0.76	M100BRBSWPG90	39	0.15	M200BRB	44	0.24
LSTM075-80C	82	0.302	M100CPG	40	0.09	M200BRB45	44	0.262
LSTM075H	83	0.16	M100CPG45	40	0.09	M200BRB90	44	0.339
LV025MTV	6	0.06	M100CPG90	41	0.14	M200CPG	40	0.43
LV025V	6	0.054	M100CR	43	0.24	M200CPG45	40	0.31
LV038050MTLV	6	0.07	M100FPT	42	0.09	M200CPG90	41	0.626
LV038050MTV	6	0.058	M100G	45	0.02	M200CPG90SH	41	0.422
LV038MTV	6	0.07	M100GV	45	0.02	M200CR	43	0.692
LV038V	6	0.07	M100MPT	42	0.08	M200FPT	42	0.29
LV050100MTLV	6	0.125	M100MPTSS	42	0.34	M200MPT	42	0.26
LV050100MTV	6	0.11	M100PA	36	0.25	M200MPTSS	42	0.81
LV050MTV	6	0.096	M100PAC	36	0.32	M200PLG	43	0.12
LV050SLLV	6	0.12	M100PAT	36	0.65	M200PLG025	43	0.084
LV050SLV	6	0.08	M100PLG	43	0.05	M200PLG038	43	0.09
LV050V	6	0.084	M100PLG025	43	0.04	M200PLG050	43	0.09
LVBH038050MTV	6	0.064	M100PLG050	43	0.04	M200PLG075	43	0.1
LVBH038V	6	0.06	M100SWFSS	40	0.32	M200PLG100	43	0.11
LVBH050V	6	0.06	M100SWP90	39	0.125	M200SWFSS	40	0.68
LVBH075100MTLV	6	0.135	M100SWPG90	39	0.13	M200SWP90	39	0.364
LVBH075100MTV	6	0.13	M100TEE	41	0.2	M200TEE	41	0.61
LVBH075MTV	6	0.13	M101G	45	0.006	M201G	45	0.05
LVBH075V	6	0.118	M102G	45, 5	0.01	M202G	45, 5	0.025
LVPL025V	6	0.06	M12712	105, 107, 109	N/A	M220100BRB	44	0.15
LVPL038V	6	0.06	M13712	113, 119	4.588	M220100CPG	41	0.15
M100050FPT	42	0.06	M19712X	141, 143	27.046	M220100TEE	41	0.403
M100050HBT	44	N/A	M200100BRB	44	0.15	M220125BRB	44	0.16
M100075BRB	44	0.06	M200100BRB90	44	0.16	M220150BRB	44	0.16
M100075BRB90	44	0.06	M200100CPG	41	0.16	M220150BRB90	44	0.21
M100075FPT	42	0.05	M200100TEE	41	0.524	M220150MPTSS	42	0.65
M100075HBT	44	N/A	M200125BRB	44	0.16	M220200CPG	41	0.2
M100075MPT	42	0.052	M200125BRB45	44	0.18	M220200HBT	44	0.39
M100100HBT	44	0.09	M200125BRB90	44	0.21	M220200SWP90	39	0.355
M100125BRB	44	0.08	M200125MPT	42	0.2	M220200TEE	41	0.566

# REFERENCE

PART NO	PAGE NO(S)	WEIGHT	PART NO	PAGE NO(S)	WEIGHT	PART NO	PAGE NO(S)	WEIGHT
M220375SWFSS	40	1.35	M300220MPTSS	42	1.332	M332PIH13W	140	155
M220A	43	0.2	M300220SWP90	39	0.57	M332PIHYW	142	190
M220ASWP90	39	0.398	M300300HBT	44	1.033	M332POIW	140	70.532
M220BRB	44	0.19	M300375SWFSS	40	3.2	MBF100	50	0.9
M220BRB45	44	0.224	M300A	43	0.35	MBF100BD	50	0.948
M220BRB90	44	0.308	M300ASWP90	39	0.896	MBF200	50	1.37
M220BRBSWP90	39	0.399	M300BRB	44	0.478	MBF200BD	50	1.44
M220BWASS	42	0.5	M300BRB45	44	0.518	MBF220	50	1.62
M220CPG	40	0.21	M300BRB90	44	0.797	MBF220BD	50	1.62
M220CPG3G	40	N/A	M300BRBSWP90	39	1.183	MBF300	50	2.34
M220CPG45	37, 40	0.24	M300CPG	40	0.416	MBF300BD	50	2.5
M220CPG6	37, 40	0.374	M300CPG12	40	1.009	MBF200	62	0.26
M220CPG90	41	0.34	M300CPG45	37, 40	0.518	MCV100	40	0.154
M220CR	43	0.577	M300CPG7	37, 40	0.631	MCV200	40	0.45
M220D	43	0.73	M300CPG90	41	0.745	MCV221	40	0.5
M220FPT	42	0.26	M300CR	43	1.214	MCV300	40	1.224
M220MPT	42	0.21	M300FPT	42	0.513	MCV301	40	1.26
M220MPTSS	42	0.62	M300MPT	42	0.436	MEVX100	24	3.82
M220MPTSWP90	39	0.33	M300MPTSS	42	1.85	MEVX100BL	27	4.7
M220P6PRO	104	N/A	M300MPTSWP90	39	0.832	MEVX100SL	27	4.7
M220PB	104	N/A	M300P11PRO	112	N/A	MEVX101	24	4.24
M220PH5	104	55	M300PB	112	N/A	MEVX1012	28	9.6
M220PH5W	106	55	M300PBW	118	24	MEVX1013	28	14.548
M220PH6	104	55	M300PH6	112	45.4	MEVX1014	28	19.485
M220PHYW	108	28	M300PH6W	118	49	MEVX1015	28	N/A
M220PLG	43	0.12	M300PLG	43	0.25	MEVX102	28	9.073
M220PLG038	43	0.1	M300PLG075	43	0.23	MEVX103	28	14.47
M220PLG075	43	0.11	M300PLG100	43	0.248	MEVX105	28	23.077
M220PO	104	8.372	M300PO	112	9.792	MEVX200BL	27	5.76
M220SWFSS	40	0.58	M300SWFSS	40	1.46	MEVX200SL	27	5.76
M220SWP90	39	0.285	M300SWP90	39	0.674	MEVX201	25	4.775
M220SWPG90	39, 41	N/A	M300SWPG90	39	0.75	MEVX220BL	27	6.98
M220TEE	41	0.522	M300TEE	41	1.111	MEVX220SL	27	6.98
M220Y45	37, 41	1.316	M300Y45	37, 41	3.32	MEVX221	25	4.775
M220YG45	37, 41	1.34	M300YG45	37, 41	3.258	MEVX300	26	8.98
M221G	37, 45	0.03	M301G	37, 45	0.03	MEVX300BL	27	18.28
M221GSA	40	0.258	M301GSA	40	0.55	MEVXR100	24	2.491
M222G	45, 5	0.03	M302G	45, 5	0.05	MEVXR100SL	27	4.7
M300200CPG	41	0.266	M303D	43	1.5	MEVXR101	24	3.82
M300220BRB	44	0.284	M305PHYW	118	26.4	MEVXR200	25	2.882
M300220BRB90	44	0.405	M332PIE101W	140	270	MEVXR200SL	27	3.979
M300220CPG	37, 41	0.244	M332PIE10W	140	N/A	MEVXR220	25	3.405

PART NO	PAGE NO(S)	WEIGHT	PART NO	PAGE NO(S)	WEIGHT	PART NO	PAGE NO(S)	WEIGHT
MEVXR220SL	27	6.627	MLS300BC	49	7.48	MVS220HSFP	31	2.88
MEVXR300	26	8.98	MLS300CAP	49, 93	1.36	MVS300CF	32	3.046
MFM100	38	2.75	MLS300ECG	49, 93	0.024	MVS300CFFP	32	3.75
MFM220	38	2.75	MLS300ECGV	49, 93	0.04	MVS300HSFP	33	6.32
MFM300	38	5.4	MLS300G	49, 93	0.03	MVSF220FP	30	1.78
MHV200	36	0.57	MLST100-100	46	0.75	MVSF300	32	3.29
MHV220A	36, 37	0.8	MLST100-30	46	0.75	MVSF300FP	32	4
MIS220	37	10.175	MLST100-50	46	0.75	MVSMT220FP	30	1.75
MIS300	37	23.06	MLST100-80	46	0.75	MVSMT300	32	3.192
MLEV100	28	0.65	MLST100-H	47	0.467	MVSMT300HSFP	33	6.44
MLEV100A	28	1.13	MLST100-HB	47	0.63	NIP025-SH	77	0.01
MLEV100C	28	N/A	MLST150-100	46	2	NIP038-SH	77	0.02
MLS100-80	46	0.88	MLST150-30	46	2	NIP050-3	77	0.04
MLS100B	47	0.645	MLST150-50	46	2	NIP050-SH	77	0.02
MLS100BC	47	0.896	MLST150-80	46	2	NIP075-4	77	0.074
MLS200-06	46	2.25	MLST150-80V	46	2.125	NIP075-6	77	0.12
MLS200-12	46	2.5	MLST150-H	47	1.291	NIP075-SH	77	0.03
MLS200-20	46	2.15	MLST150-HB	47	1.75	NIP100-4	77	0.09
MLS200-30	46	2.15	MPRV100-050	35	1.506	NIP100-6	77	0.14
MLS200-50	46	3.9	MPRV100-075	35	1.45	NIP100-SH	77	0.038
MLS200-80	46	2.15	MPRV100-100	35	1.5	NIP125-4	77	0.136
MLS200B	47	1.525	MPRV100-125	35	1.54	NIP125-6	77	0.22
MLS200BC	47	2.07	MSUV100FP	15	0.46	NIP125-SH	77	0.06
MLS2100SS	49	0.54	MSW220	40	0.4	NIP150-3	77	0.14
MLS220C1	49	0.82	MTF220BD	50	0.75	NIP150-4	77	0.22
MLS220G1	49	0.008	MTF300BD	50	2.092	NIP150-5	77	0.26
MLS220R1	49	0.416	MV100BL	34	1.2	NIP150-6	77	0.34
MLS222-04	48	3.82	MV100CF	29	0.75	NIP150-SH	77	0.12
MLS222-10	48	3.5	MV100SL	34	1.13	NIP200-4	77	0.25
MLS222-16	48	3.7	MV200BL	34	2	NIP200-6	77	0.38
MLS222-30	48	3.75	MV200CF	29	2.024	NIP200-SH	77	0.14
MLS222-50	48	3.75	MV200SL	34	2	NIP2101	62	0.3
MLS222-80	48	3.7	MV220BL	34	4.63	NIP300-4	77	0.434
MLS222B	49	2.2	MV220CF	29	2.798	NIP300-6	77	0.695
MLS222BC	49	3.25	MV220SL	34	2.75	NIP300-SH	77	0.306
MLS250SS	49	0.6	MV225CF	29	7.3	PLUG025	78	0.03
MLS280SS	49	0.57	MV300	29	3.9	PLUG038	78	0.02
MLS300-12	48	8	MV300BL	34	6.68	PLUG050	78	0.02
MLS300-20	48	8	MV300CF	29	5.866	PLUG075	37, 78	0.04
MLS300-50	48	8.44	MV301CF	37	6	PLUG100	78	0.06
MLS300B	49	5.009	MVS220CF	30, 37	1.744	PLUG125	78	0.09
MLS300B1	93	5.356	MVS220FP	30	1.804	PLUG150	78	0.1

# REFERENCE

PART NO	PAGE NO(S)	WEIGHT	PART NO	PAGE NO(S)	WEIGHT	PART NO	PAGE NO(S)	WEIGHT
PLUG200	78	0.152	RN125-075	77	0.086	TC193	76	0.12
PLUG300	78	0.445	RN125-100	77	0.08	TC206	76	0.14
PRC200	95	34.1	RN150-100	77	0.122	TC218	76	0.13
PV075	16	0.53	RN150-125	77	0.14	TC224	76	0.14
PV100	16	0.52	RN200-125	77	0.16	TC231	76	0.15
PV100-075	16	0.64	RN200-150	77	0.17	TC250	76	0.16
PV100-075V	16	0.35	RN300-200	77	0.364	TC287	76	0.17
PV10265	16	0.07	RS21	81	0.756	TC312	76	0.16
PV10265V	16	0.2	RSTB	81	0.704	TC331	76	0.17
RB038-025	77	0.01	SL025-90	79	0.02	TC343	76	0.17
RB050-025	77	0.02	SL038-90	79	0.03	TC425	76	0.18
RB050-038	77	0.01	SL050-90	79	0.06	TC438	76	0.36
RB075-025	77	0.04	SL075-45	79	0.07	TC456	76	0.38
RB075-038	77	0.03	SL075-90	79	0.08	TEE025	78	0.02
RB075-050	77	0.03	SL100-45	79	0.1	TEE038	78	0.05
RB100-025	77	0.07	SL100-90	79	0.13	TEE050	78	0.1
RB100-050	77	0.05	SL125-45	79	0.14	TEE075	78	0.14
RB100-075	77	0.04	SL125-90	79	0.14	TEE100	78	0.21
RB125-075	77	0.09	SL150-45	79	0.22	TEE125	78	0.32
RB125-100	77	0.06	SL150-90	79	0.25	TEE150	78	0.445
RB150-075	77	0.12	SL200-45	79	0.34	TEE200	78	0.584
RB150-100	77	0.1	SL200-90	79	0.41	TEE300	78	1.593
RB150-125	77	0.1	SL300-45	79	0.833	TEG075	78	0.14
RB200-075	77	0.18	SL300-90	79	1.053	TEG100	78	0.22
RB200-100	77	0.17	ST200	63	0.809	TF038SS	67	0.25
RB200-125	77	0.14	ST300	63	1.331	TF050	67	0.25
RB200-150	77	0.12	SUV050FP	15	0.25	TF050SS	67	0.8
RB300-150	77	0.414	SUV075FP	15	0.4	TF075	67	0.2
RB300-200	77	0.359	SUV100FP	15	0.4	TF075SS	67	1.15
RB400-300	77	1.031	SUV125FP	15	0.88	TF075V	67	0.22
RC100-075	77	0.15	SUV150FP	15	0.88	TF100	67	0.35
RC150-100	77	0.2	SUV200FP	15	1.45	TF100AV	68	0.44
RC150-125	77	0.206	SW100	81	0.16	TF100SS	67	2.85
RC200-050	77	0.28	SW150	81	0.36	TF125	67	0.35
RC200-100	77	0.26	SW220	81	0.52	TF125AV	68	0.386
RC200-125	77	0.26	TA283	64	0.2	TF125SS	67	1.92
RC200-150	77	0.26	TA283QD	64	0.3	TF138GV	67	0.1
RC300-200	77	0.623	TC120	76	0.1	TF150	67	0.63
RN050-038	77	0.018	TC130	76	0.1	TF150AV	68	0.68
RN075-050	77	0.03	TC150	76	0.11	TF150SS	67	4.88
RN100-050	77	0.06	TC162	76	0.12	TF200	67	0.55
RN100-075	77	0.06	TC181	76	0.14	TF200AV	68	0.596

PART NO	PAGE NO(S)	WEIGHT	PART NO	PAGE NO(S)	WEIGHT	PART NO	PAGE NO(S)	WEIGHT
TF200SS	67	3.6	V10119	101, 121, 123, 125, 127, 129, 141, 147, 149, 151, 153	0.1	VSBHB204FP	5	2.675
TF200V	67	0.56	V10153138	7	0.07	VSBHB205FP	5	2.965
TF220	67	0.82	V10161	14	0.176	VSBHB304FP	5	5.1
TF220G	67	0.038	V10264	145	0.002	VSBHB305FP	5	5.52
TF220SS	67	5.27	V10270	7	0.138	VSF200	10	1.25
TF300	67	2	V10271	7	0.14	VSF200CF	30	1.49
TF300G	67	0.094	V125	7	1.25	VSF200PPAF	9	3.05
TF300SS	67	7.9	V125BL	13	2.126	VSF204FP	11	1.82
TF400	67	4.5	V125FP	7	1.91	VSF300	12	3.424
TF400G	67	0.7	V125SL	13	2.07	VSFHB200	10	1.52
TF400GV	67	0.752	V150	7	1.87	VSFMT200	10, 12	1.562
TL600C	63	0.46	V150BL	13	2	VSFMT204FP	11	1.862
TL650S	63	0.5	V150SL	13	2	VSFMT204HSFP	11	2.95
TL651S	63	0.7	V200	7	1.88	VSFMT300	12	N/A
TL652E	63	0.64	V20011SS	139	0.064	VSFMT300FP	12	4.29
TL652S	63	0.63	V20018	101, 103, 109, 115, 125, 127, 131, 133, 135, 137, 139, 145, 149, 151, 153	0.004	VSFMT300HSFP	12	6.63
TL6531	64	0.084	V20019	131, 133, 135, 137, 153	0.016	VSMT200	10, 12	1.35
TLVA10	63	2.25	V200BL	13	2.8	VSMT200CF	30	1.432
TM075/050	81	0.16	V200FP	8	3.25	VSMT204FP	11	1.874
UB100	41	0.24	V200SL	13	2.75	VSMT300	12	N/A
UB202	41	0.26	V20153138	7	0.176	VSS025	16	0.634
UB220	41	0.32	V20207	64, 73	0.006	VSS038	16	0.59
UV050FP	15	0.25	V204FP	9	2.74	VSS050	16	0.7
UV075FP	15	0.25	V25153138	7	0.16	VSS075	16	1.298
UV100FP	15	0.37	V25270	7, 8	0.194	VSS100	16	2.094
UV125FP	15	1	V25271	7, 8	0.356	VSS150	16	3.996
UV150FP	15	1	V300	8	3.75	VSS200	16	6.808
UV15163	101, 103, 107, 109, 117, 119, 121, 123, 125, 127, 133, 135, 137, 141, 143, 47, 85, 89, 97, 99	0.002	V300FP	8	5.67	VSS300	16	18.43
UV15163V	101, 117, 147, 149, 151, 153, 89, 97	0.002	V400	8	8.5	W230237	61	1.07
UV200FP	15	1.5	VA150	14	2.592	W230238	61	1.17
UV204FPFD	62	1.58	VA200	14	2.8	W230239	61	1.07
V050	7	0.75	VA200FP	14	3.958	W230240	61	1.1
V07018	101, 103, 105, 107, 109, 111, 113, 115, 117, 119, 97, 99	0.1	VC200	68	0.218	WSF210FSA	61	1.2
V07019	101, 103, 105, 107, 109, 111, 113, 115, 117, 119, 97, 99	0.008	VC230	68	0.26	WSF210FSAV	61	1
V075	7	0.75	VC300	68	0.54	WSMT210FSA	61	1.07
V075BL	13	1.35	VC330	68	0.68	WSMT210FSAV	61	1
V075SL	13	1.35	VFMT200FP	8	3.368			
V100	7	0.682	VFMT204FP	9	3.33			
V100BL	13	1.25	VL20153	7	0.35			
V100FP	7	1.16	VL25153	8	0.41			
V100SL	13	1.31	VN100	14	0.712			
V10118	121, 123, 125, 127, 129, 131, 141, 143, 147, 149, 151, 153	0.004	VS204FP	11	1.834			



ORIALOO #032022

BANJO LIQUID HANDLING PRODUCTS

WWW.ROLTRONIK.FL



Liquid Handling Products  
**BANJO CORPORATION**  
A Unit of IDEX Corporation  
150 Banjo Drive  
Crawfordsville, IN 47933 U.S.A.  
Telephone: (765) 362-7367  
Fax: (765) 362-0744  
banjocorp.com  
#yellowhandle

Follow us on:



Scan to visit  
BanjoCorp.com

