

# XWP

VERSION

# N

# 1450<sub>rpm</sub>

# ∅ 24 mm

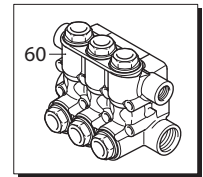
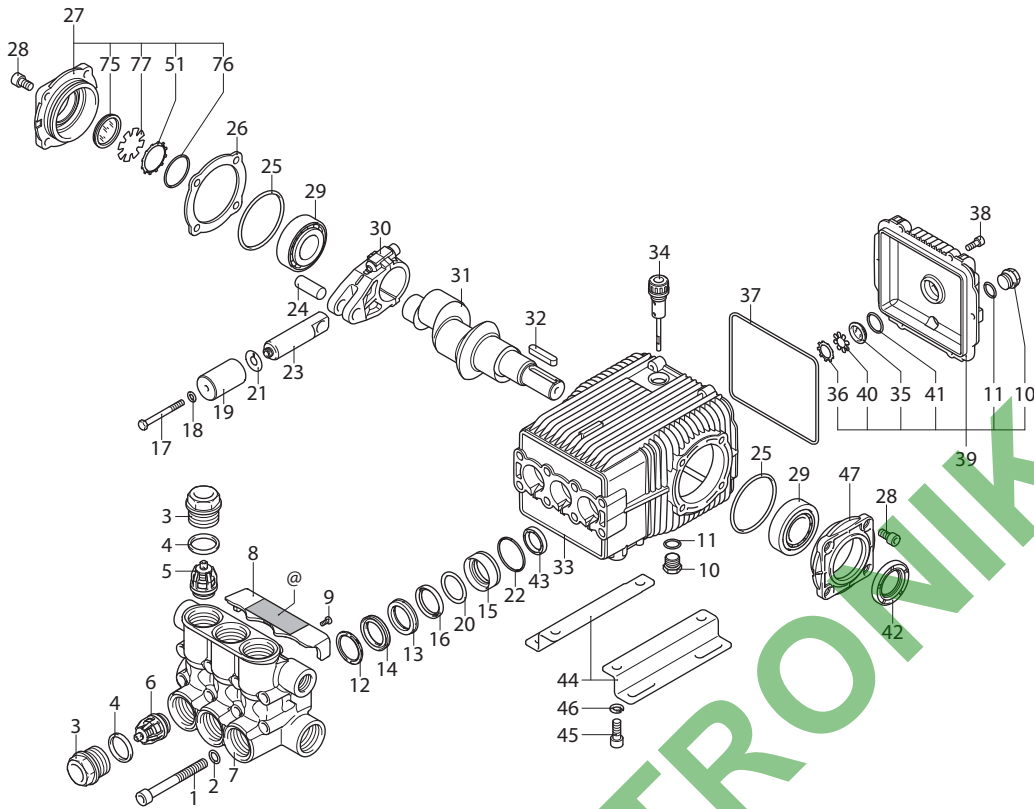

UN004189-GP

## KIT RICAMBI / PART KITS

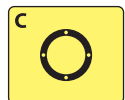
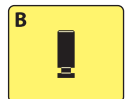
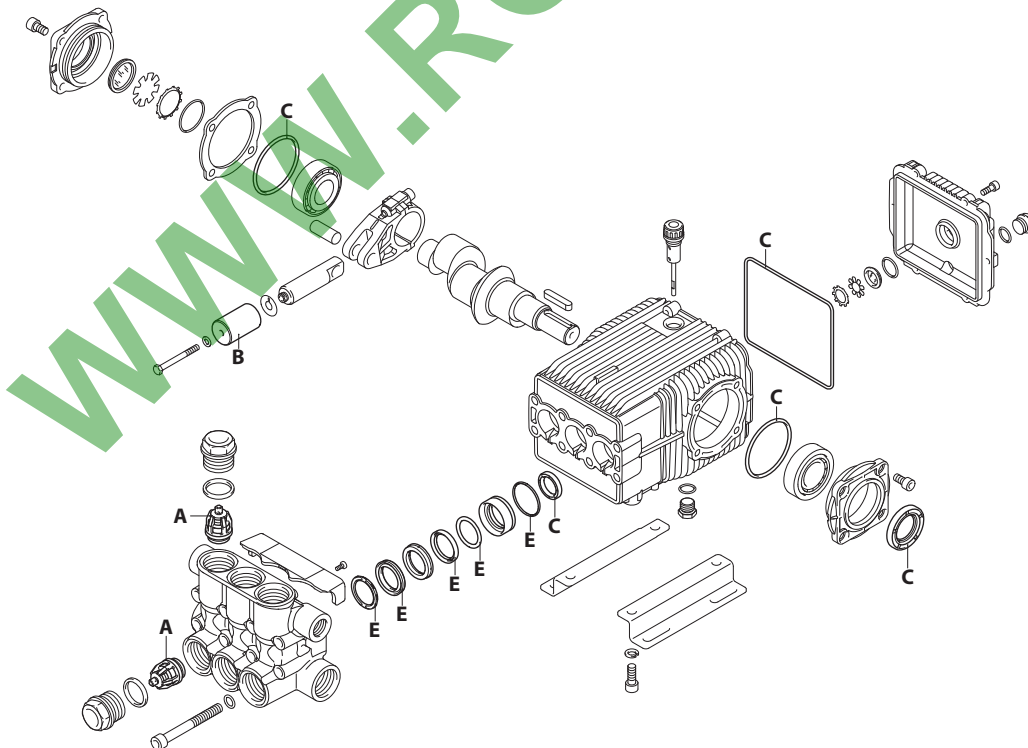

UN004190-GP

# 194 Series

XWP 1450 rpm N version ø 24 mm



50.15 (26283)  
55.14 (26284)  
60.13 (26285)

65.12 (26286)  
70.12 (26287)  
70.15 (26919)

Pos.	Cod.	Denominazione	Description	Qt	Note	Pos.	Cod.	Denominazione	Description	Qt	Note
1	850260	Vite TCEI M10x90	Screw	8	C=50Nm	38	1200430	Vite TCEI M6x16	Screw	6	C=10,4 Nm
2	650530	Rondella	Washer	8		39	1949010	Coperchio completo	Cover	1	
3	1943630	Tappo	Plug	6	C=250Nm	40	1780690	Disco	Plate	1	
4	390291	Guarnizione OR ø 28,25x2,62	O-ring	6		41	1140450	Guarnizione OR ø 20,24x2,62	O-ring	1	
5	3669051	Valvola completa	Complete valve	3		42	820680	Anello tenuta	Ring	1	(b)
6	3669050	Valvola completa	Complete valve	3		43	1943730	Anello tenuta	Ring	3	
7	1943620	Testa	Head	1		44	1940370	Piede	Foot	2	Optional
8	1943640	Supporto	Support	1		45	1940380	Vite TCEI 10x18	Screw	4	Optional C=50 Nm
9	1271880	Vite TC 14x10	Screw	2		46	200231	Rondella	Washer	4	Optional
10	1980740	Tappo 3/8" G ottone	Plug	2	C=20Nm	47	1941240	Supporto	Support	1	
11	740290	Guarnizione OR ø 14x1,78	O-ring	2		51	1941290	Anello	Ring	1	
12	1943650	Anello ø 30,2x40x4,2	Ring	3		60	1949251	Premontaggio testa	Head assembly	1	
13	1943670	Guida pistone anteriore ø 30	Piston guide	3		75	1941270	Indicatore livello	Level gauge	1	
14	1943660	Guarnizione 30x40x6	Gasket	3	☒ (a)	76	100410	Guarnizione OR ø 34,6x2,62	O-ring	1	
15	1943700	Guida pistone posteriore ø 30	Piston guide	3		77	1941260	Disco	Plate	1	
16	1943680	Guarnizione 30x38x5,5	Gasket	3	☒						
17	1941640	Vite TE M6x40	Screw	3	C=8Nm						
18	1340600	Rondella	Washer	3							
19	1943610	Pistone ø 30	Piston	3							
20	3660500	Anello antiestrusione	Ring	3							
21	1383190	Disco	Plate	3							
22	1140490	Guarnizione OR ø 37,82x1,78	O-ring	3							
23	1940960	Pistone di guida	Piston	3							
24	1940060	Perno	Hub pin	3							
25	1941380	Guarnizione OR ø 66,34x2,62	O-ring	2							
26	1941390	Spessore 0,05 mm	Shim 0.05 mm	1÷3							
	1941400	Spessore 0,10 mm	Shim 0.10 mm	1÷3							
	1941410	Spessore 0,19 mm	Shim 0.19 mm	1÷3							
	1941420	Spessore 0,25 mm	Shim 0.25 mm	1÷3							
27	1949011	Coperchio	Cover	1							
28	850370	Vite TCEI M8x16	Screw	8	C=24,5Nm						
29	1140410	Cuscinetto	Bearing	2							
30	1940051	Biella alluminio	Connecting-rod	3	● C=20Nm ●						
	1943720	Biella alluminio	Connecting-rod	3	● C=20Nm ●						
	1940180	Albero marcato 3	Shaft	1	●						
	1940160	Albero marcato 1	Shaft	1	○						
	1943510	Albero marcato 12	Shaft	1	◆						
31	1943710	Albero marcato 15	Shaft	1	⊕						
32	650250	Linguetta	Key	1							
33	1941330	Corpo pompa	Pump body	1							
34	1140370	Tappo	Plug	1							
35	1260250	Indicatore livello	Level gauge	1							
36	1260430	Anello	Ring	1							
37	1940410	Guarnizione OR ø 132x3	O-ring	1							

## KIT RICAMBI - PART KITS

A=KIT 42835 valvole valves		B=KIT 43444 ø 30 pistoni pistons		C=KIT 43445 tenute olio oil seal		E=KIT 43446 ø 30 tenute acqua water seals	
Pos.	Q.ty	Pos.	Q.ty	Pos.	Q.ty	Pos.	Q.ty
5	3	19	3	25	2	12	3
6	3			37	1	14	3
				42	1	16	3
				43	3	20	3
						22	3

Pos.	Q.ty	Pos.	Q.ty	Pos.	Q.ty	Pos.	Q.ty

## SIMBOLOGIA - SYMBOLS

● Per / For XWP 50.15 cod. 26283	◆ Per / For XWP 55.14 cod. 26284	○ Per / For XWP 60.13 cod. 26285 XWP 65.12 cod. 26286	⊕ Per / For XWP 70.12 cod. 26287 XWP 70.15 cod. 26919
-------------------------------------	-------------------------------------	---	---

- C Tolleranza coppia di serraggio +0÷-10% / Tightening torque tolerance +0÷-10%
- Avvitare con Loxeal 55-14 / Screw with Loxeal 55-14
- ☒ Lubrificare con grasso Molykote PG54 solo sul diametro INTERNO / Lubricate with grease Molykote PG54 on the INNER diameter only
- (a) Montare con attrezzo speciale cod. 1940670 / Fit with special tool code nr. 1940670
- (b) Montare anello tenuta con attrezzo cod. 1941990 / Fit the seal with tool code nr. 1941990
- @ Posizionamento targa di identificazione / Identification plate positioning

### Olio - Oil

Tipo / Type	Quantità / Quantity
SAE 15W40	0,9 Kg