

Xénon	Boite 25km/h 1 moteur / 25km/h Gearbox 1 engine	21.11.2012
Matrot	230710000	Chap. 02
		P. 1

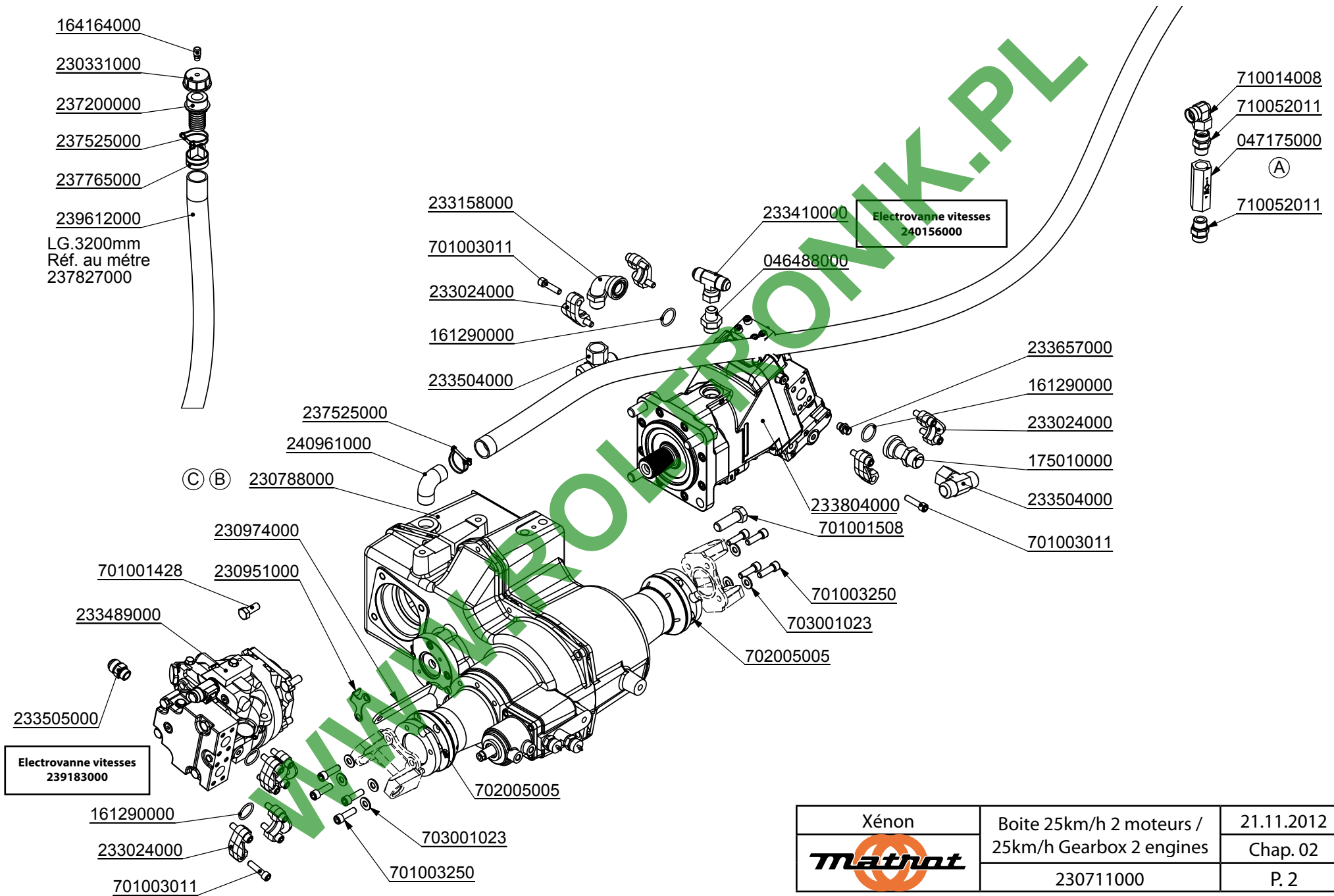

Xénon	Boîte 25km/h 2 moteurs / 25km/h Gearbox 2 engines	21.11.2012
Mathot	230711000	Chap. 02
		P. 2

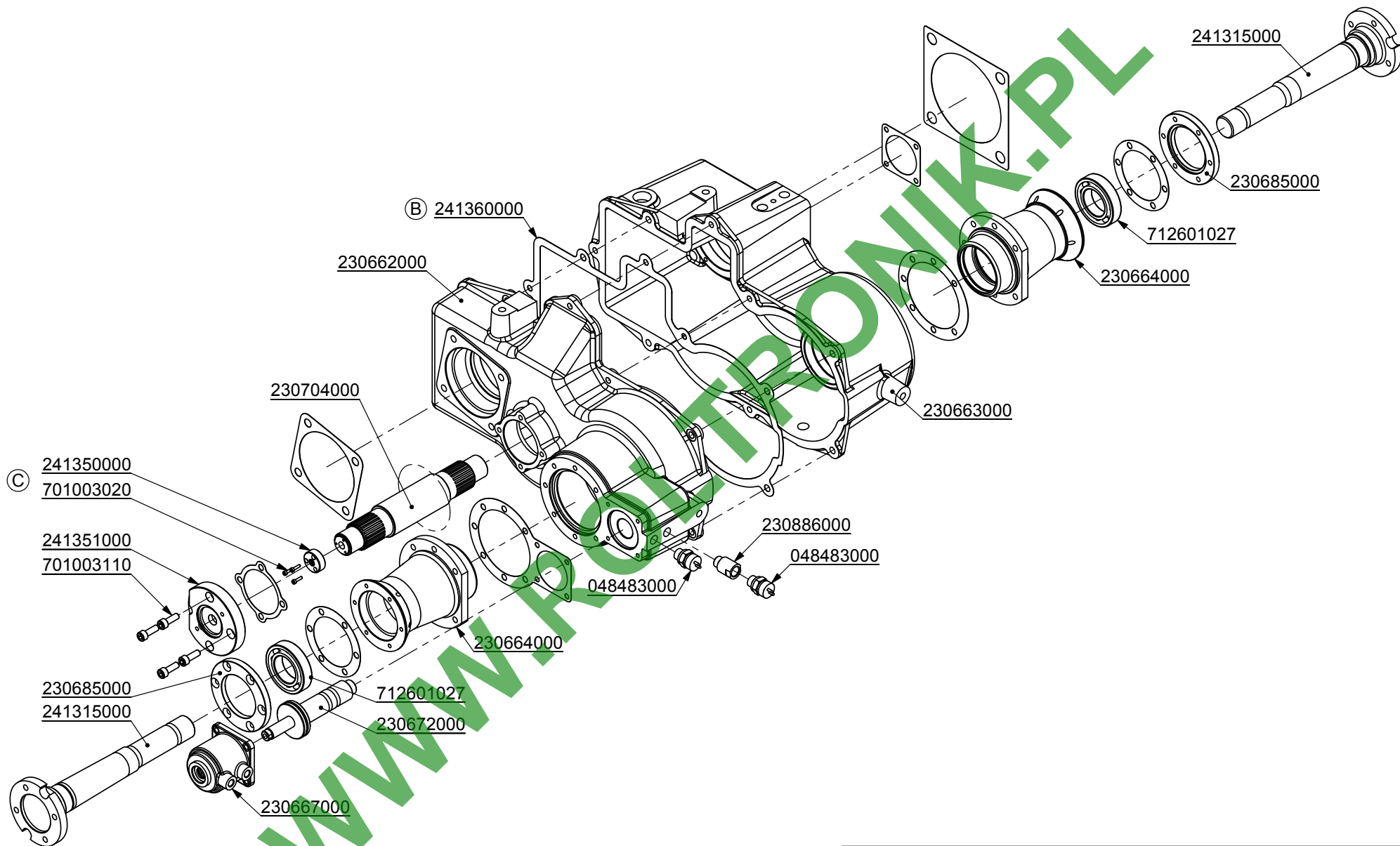

Xénon	Boîte 25km/h 2 moteurs / 25km/h Gearbox 2 engines	21.11.2012
Mathot		Chap. 02
	230788000	P. 3

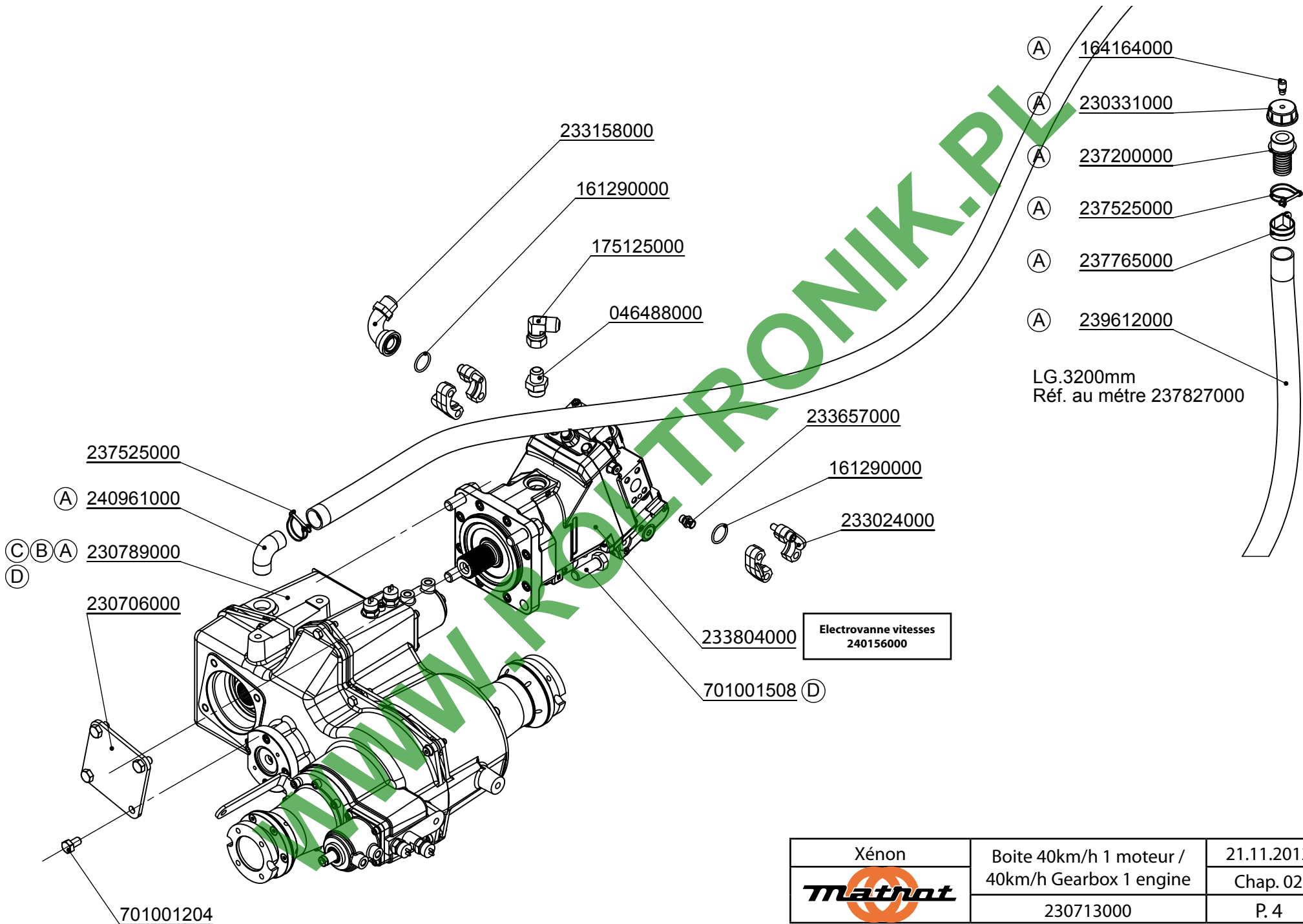

Xénon	Boite 40km/h 1 moteur / 40km/h Gearbox 1 engine	21.11.2012
Matrot	230713000	Chap. 02
		P. 4

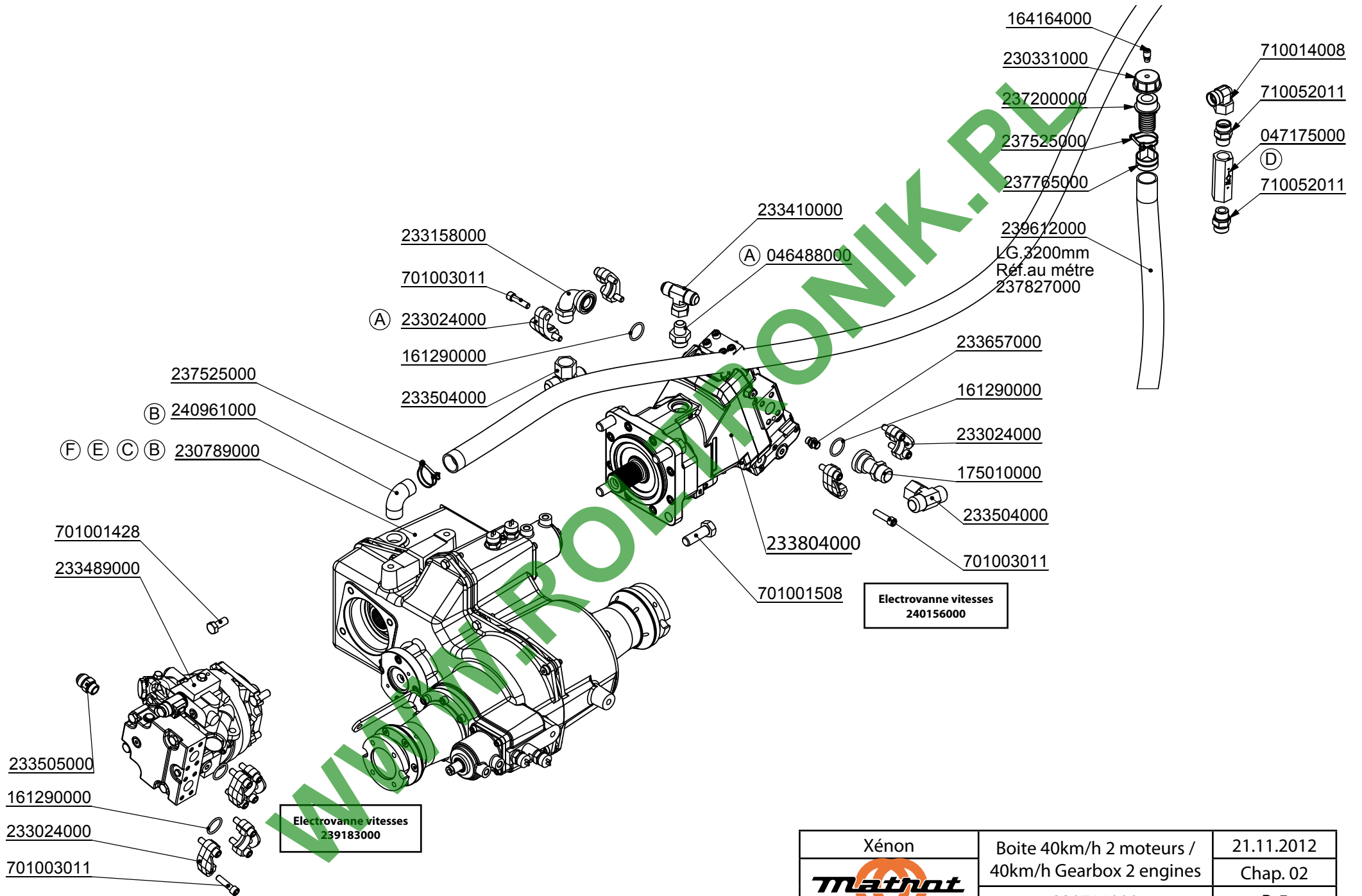

Xénon	Boîte 40km/h 2 moteurs / 40km/h Gearbox 2 engines	21.11.2012
Mathot	230714000	Chap. 02
		P. 5

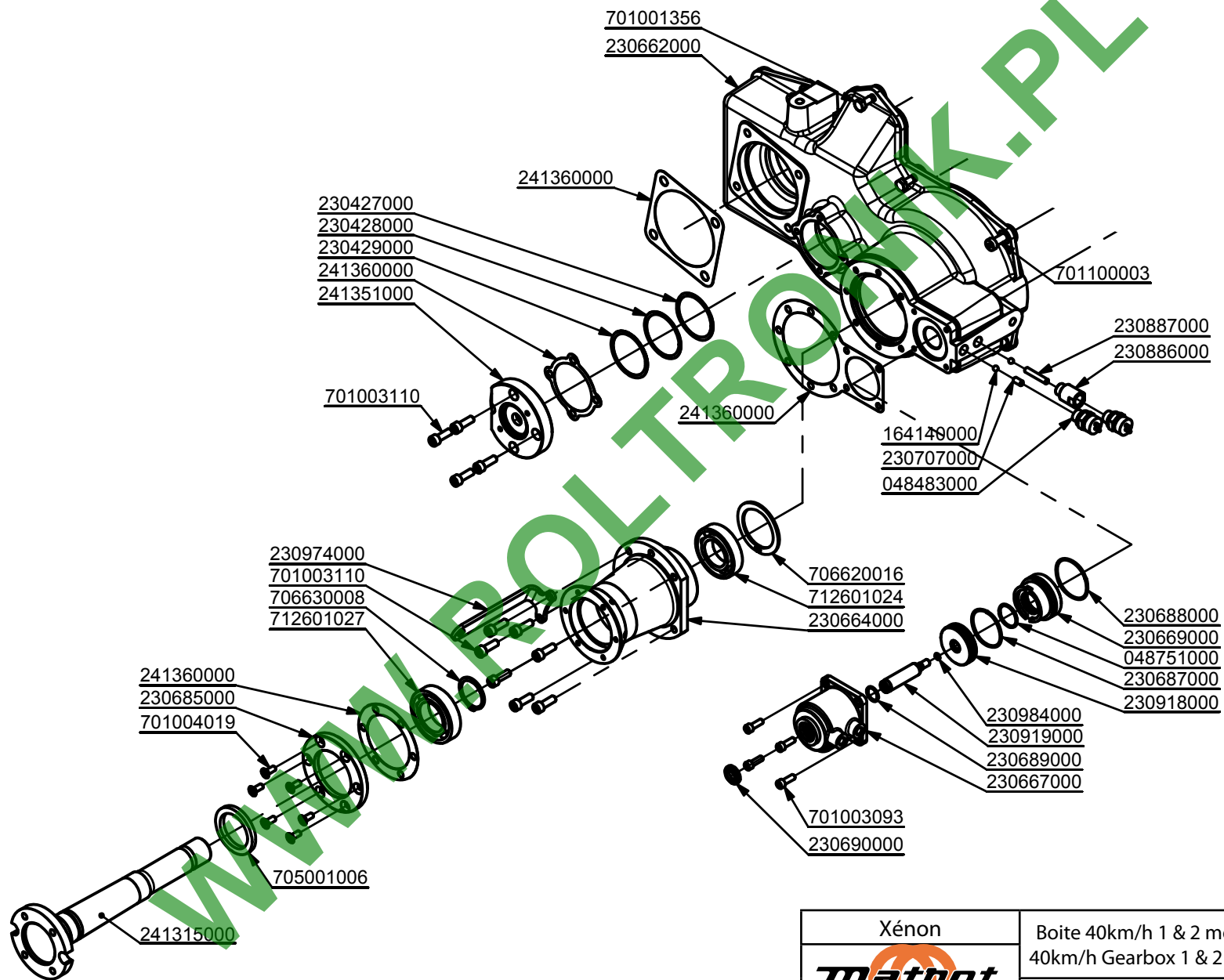

Xénon	Boite 40km/h 1 & 2 moteurs / 40km/h Gearbox 1 & 2 engines	21.11.2012
Mathot		Chap. 02
	230789000	P. 6

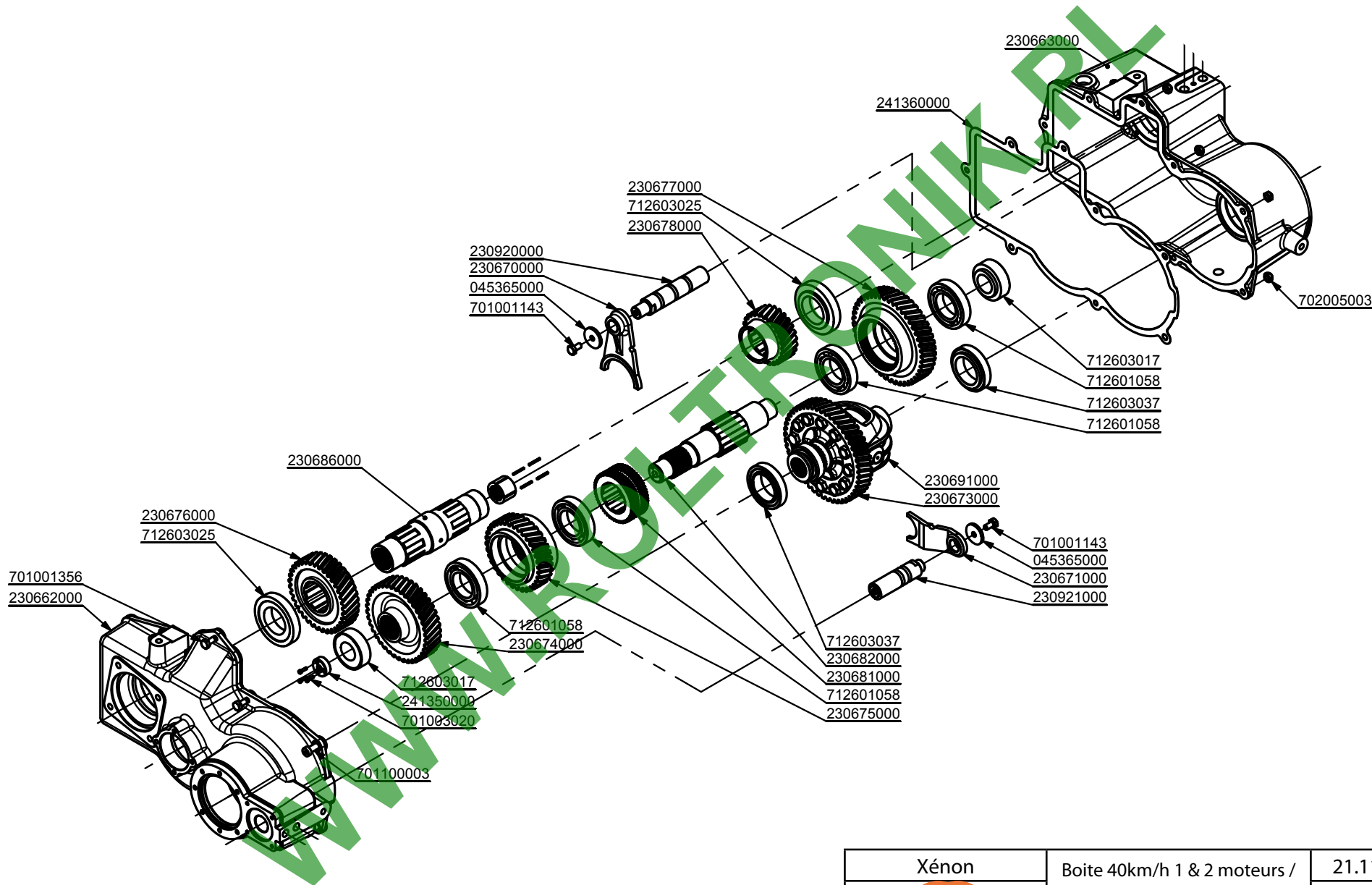

Xénon	Boite 40km/h 1 & 2 moteurs / 40km/h Gearbox 1 & 2 engines	21.11.2012
Mathot		Chap. 02
	230789000	P. 7

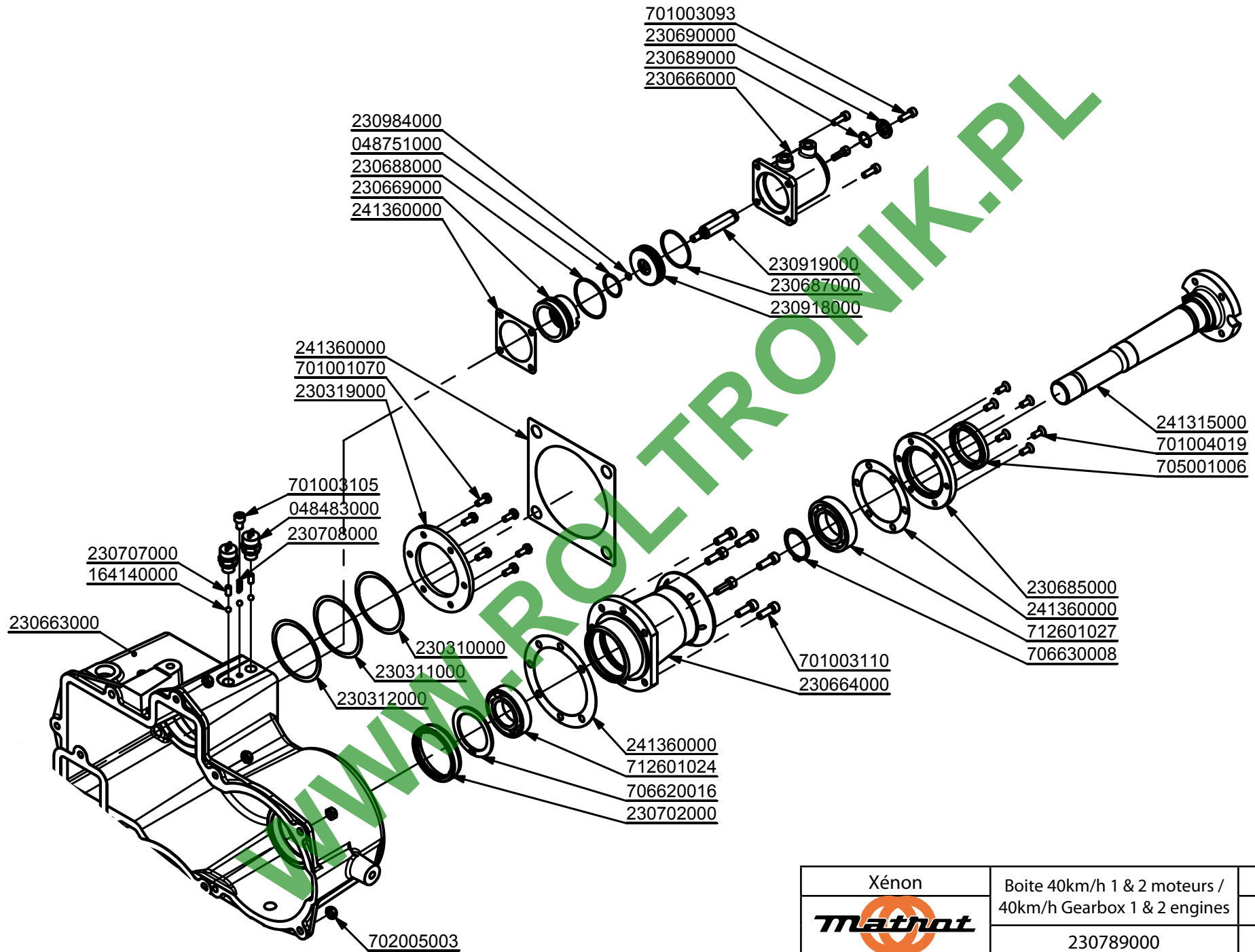

Xénon	Boite 40km/h 1 & 2 moteurs / 40km/h Gearbox 1 & 2 engines	21.11.2012
Mathot		Chap. 02
	230789000	P. 8

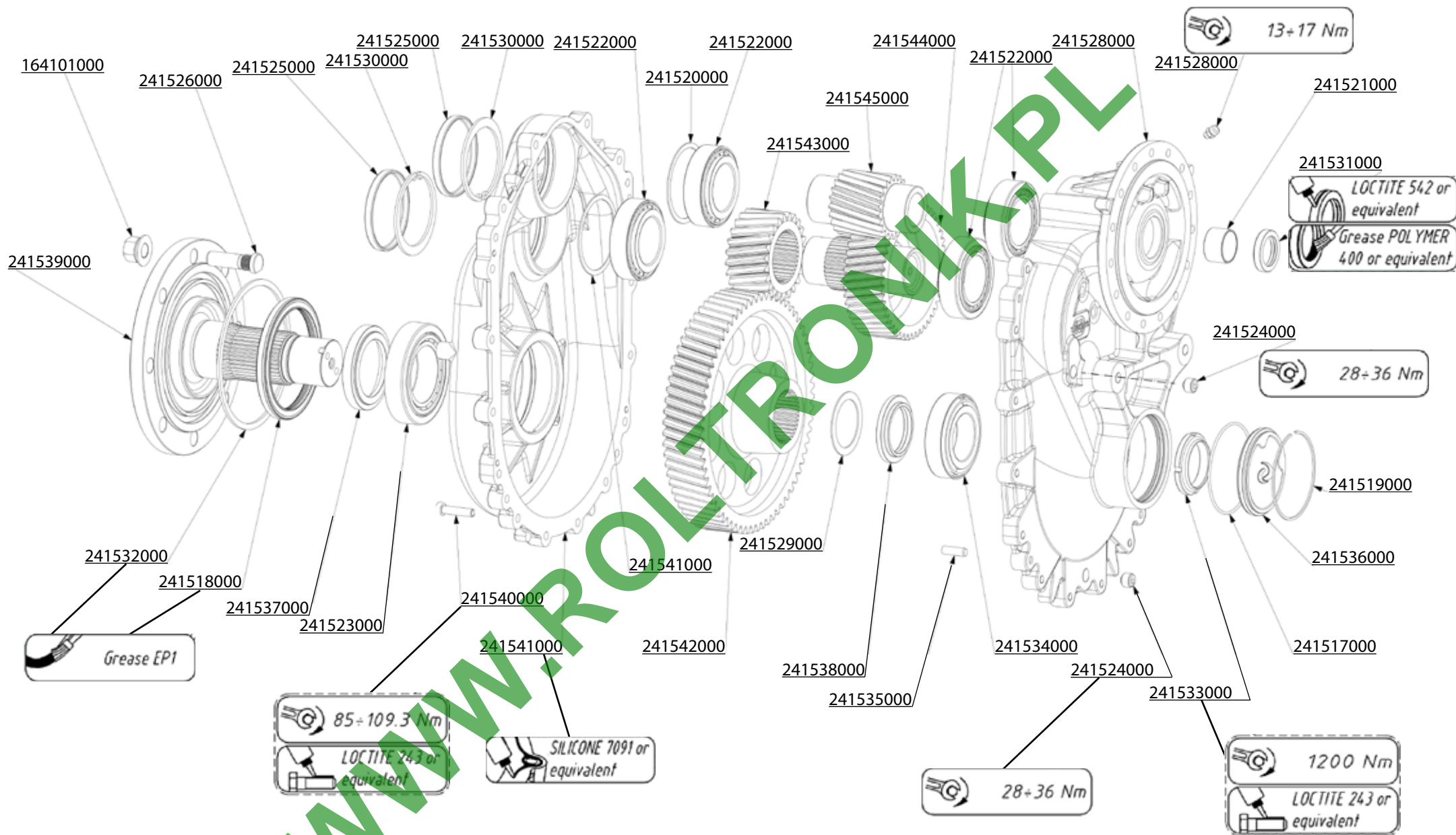

Xénon	Réducteur	29.10.2014
		Chap. 02
	241272000	P. 9

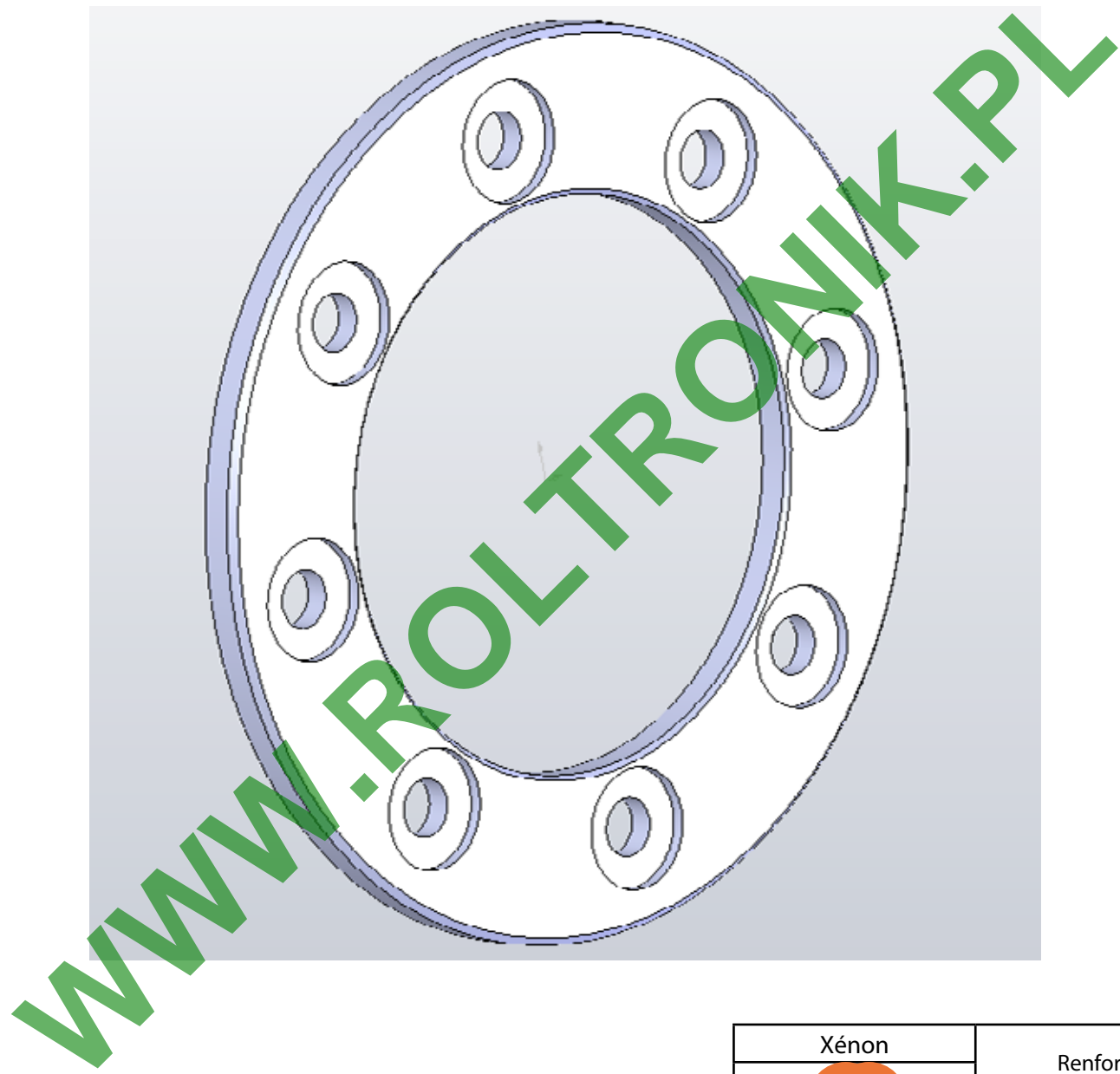

Xénon	Renfort de voile	29.10.2014
	241558000	Chap. 02
		P. 10

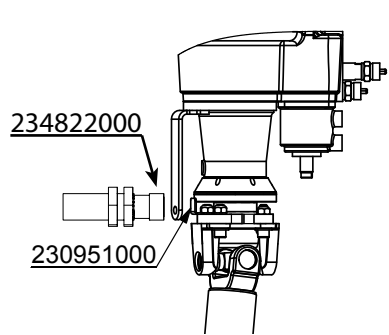

Capteur vitesse / Speed Sensor
234822000

Connecteur pour capteur de vitesse
176695000

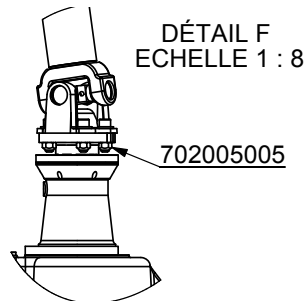

MONTAGE ECROU DEFORME
SUR ARBRE DE BOITE

DÉTAIL F
ECHELLE 1 : 8

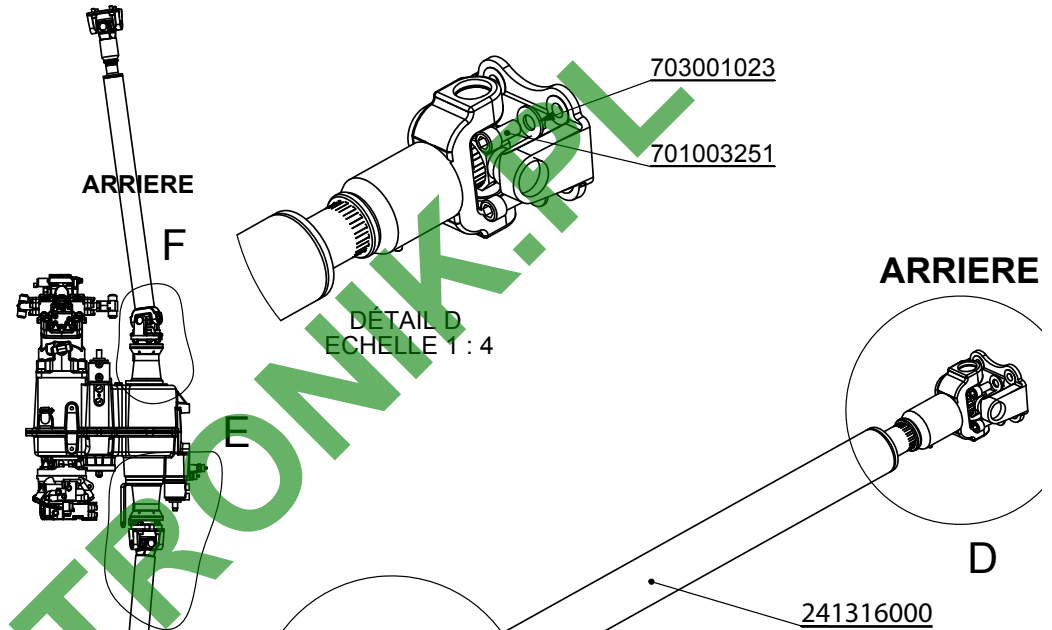

ARRIERE

AVANT

ARRIERE

DÉTAIL D
ECHELLE 1 : 4

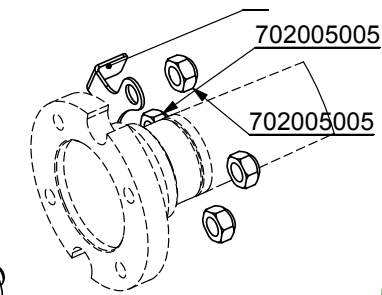

DÉTAIL A
ECHELLE 1 : 3

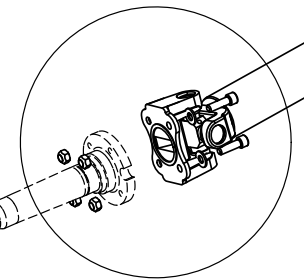

B

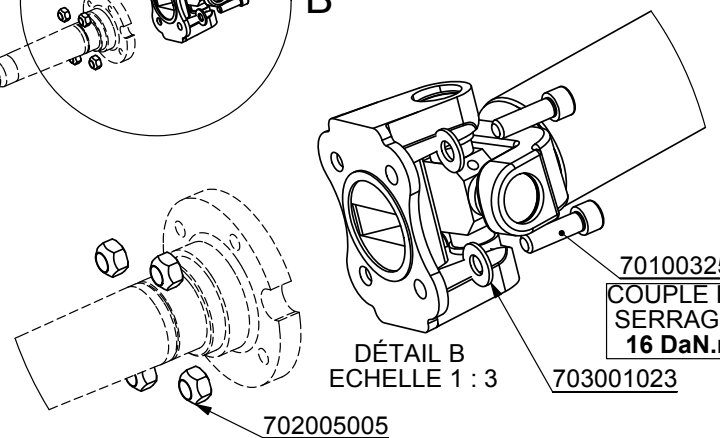

DÉTAIL B
ECHELLE 1 : 3

701003250 8 X
COUPLE DE
SERRAGE :
16 DaN.m

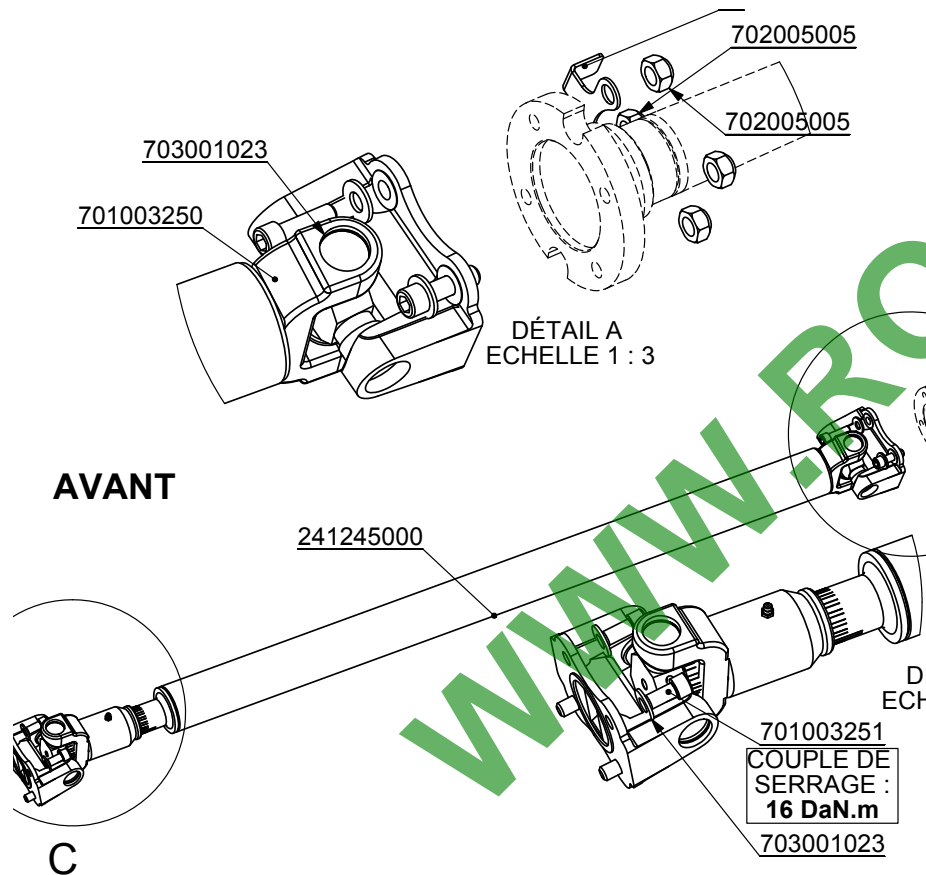

AVANT

DÉTAIL C
ECHELLE 1 : 4

701003251
COUPLE DE
SERRAGE :
16 DaN.m
703001023

WWW.ROLTRONK.COM

Xénon	Cardans / Universals Joints	30.09.2011
Mathot	241333000	Chap. 02
		P. 11

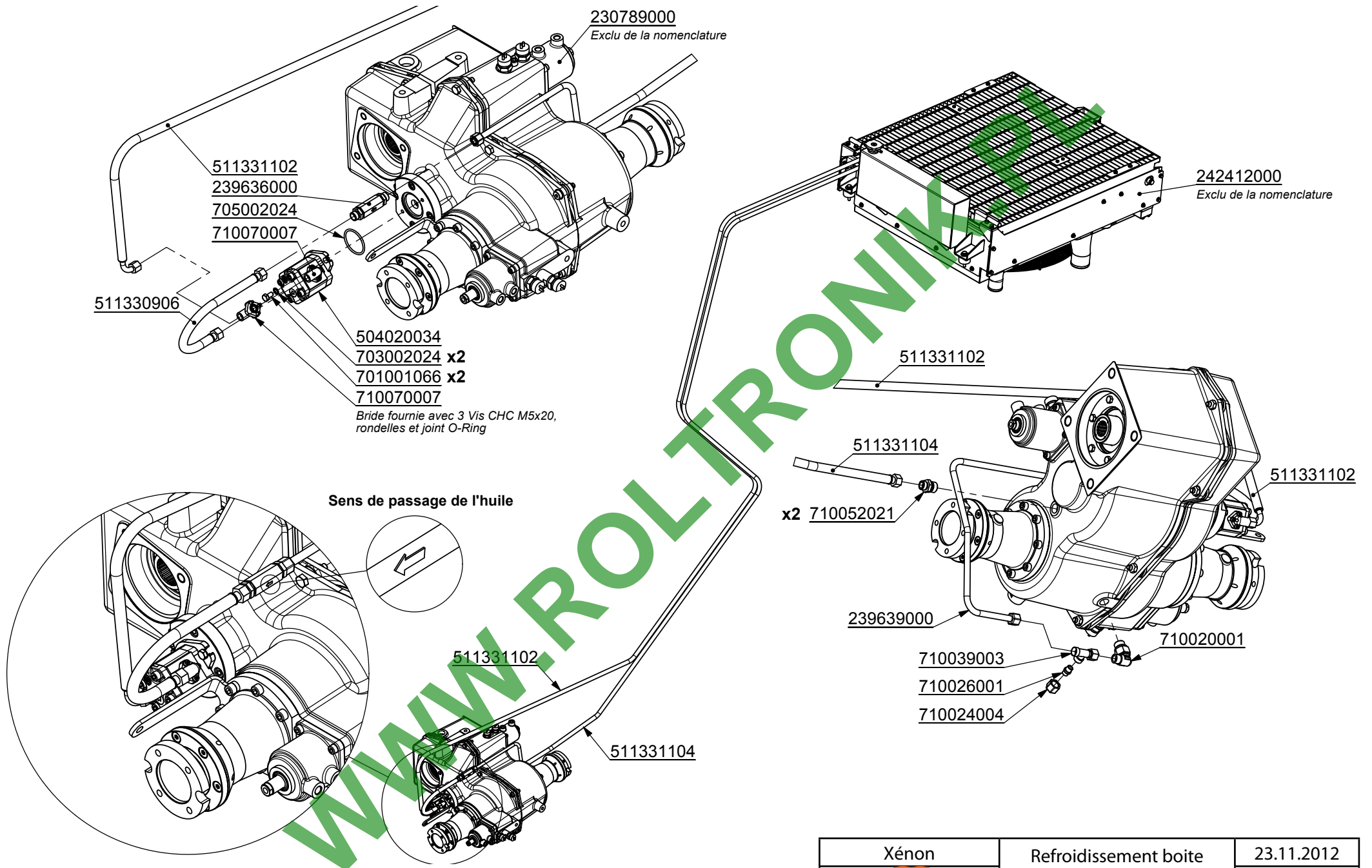

Xénon	Refroidissement boîte	23.11.2012
	Tier IIIA	Chap. 02
	239643000	P. 12

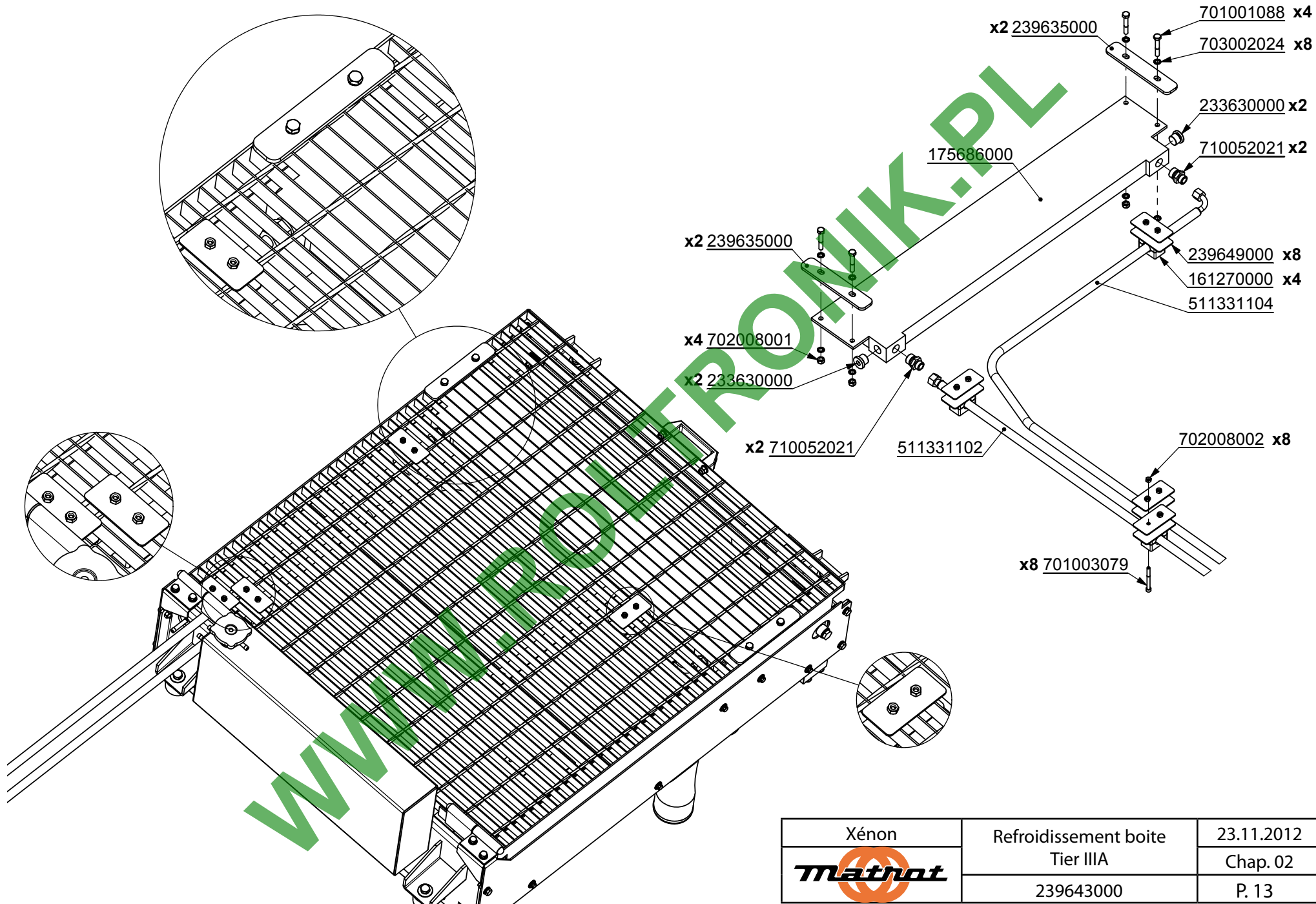

Xénon	Refroidissement boîte	23.11.2012
	Tier IIIA	Chap. 02
	239643000	P. 13

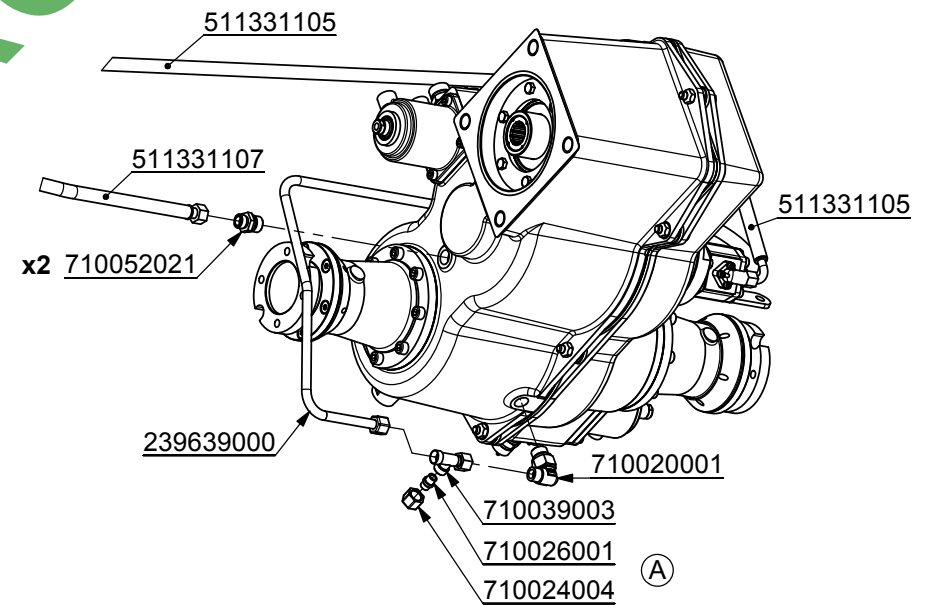
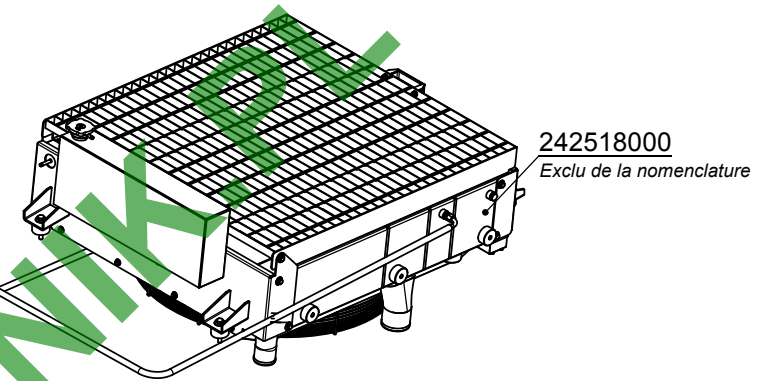
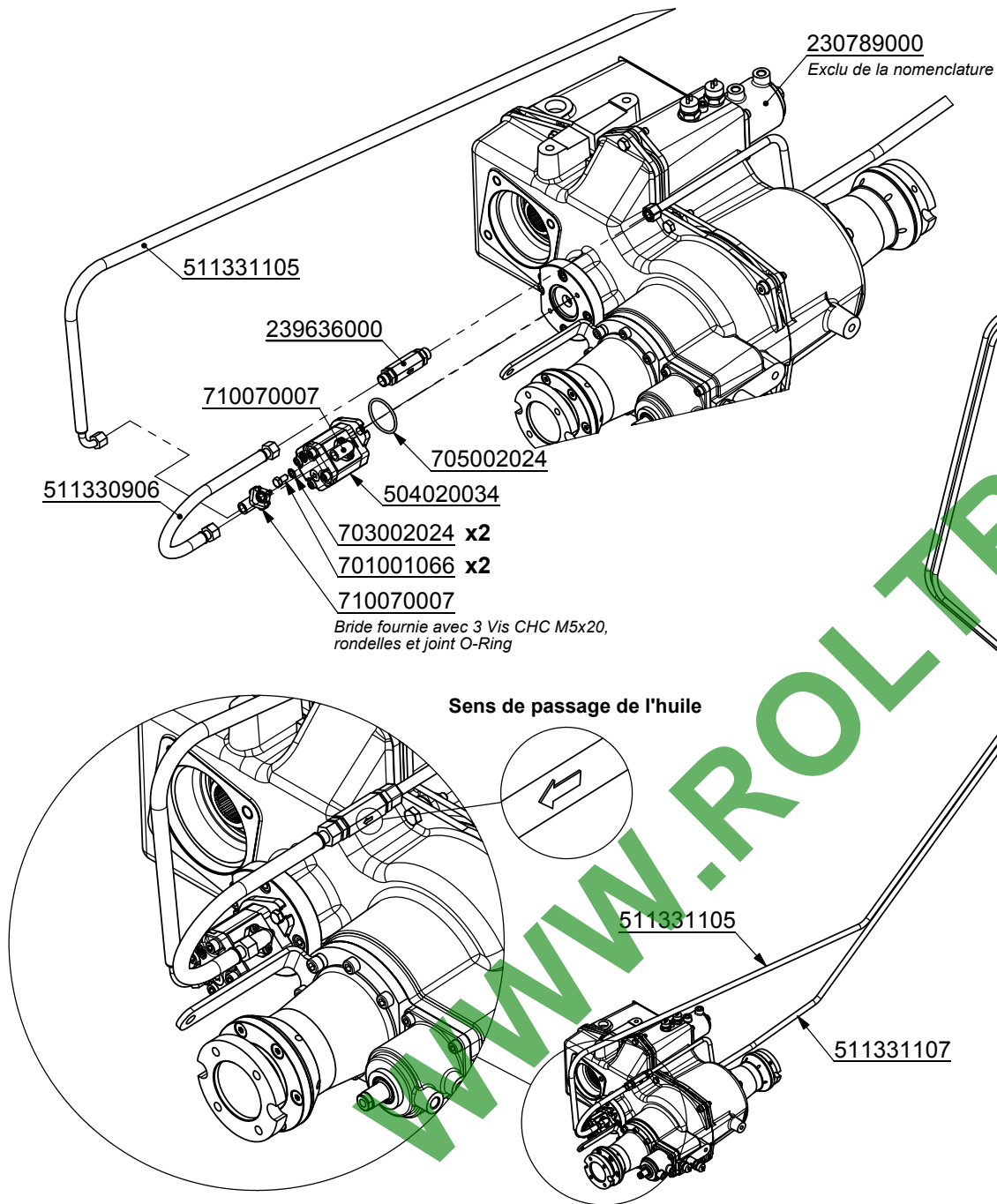

Xénon	Refroidissement boîte	26.11.2012
	Tier IIIB	Chap. 02
	239647000	P. 14

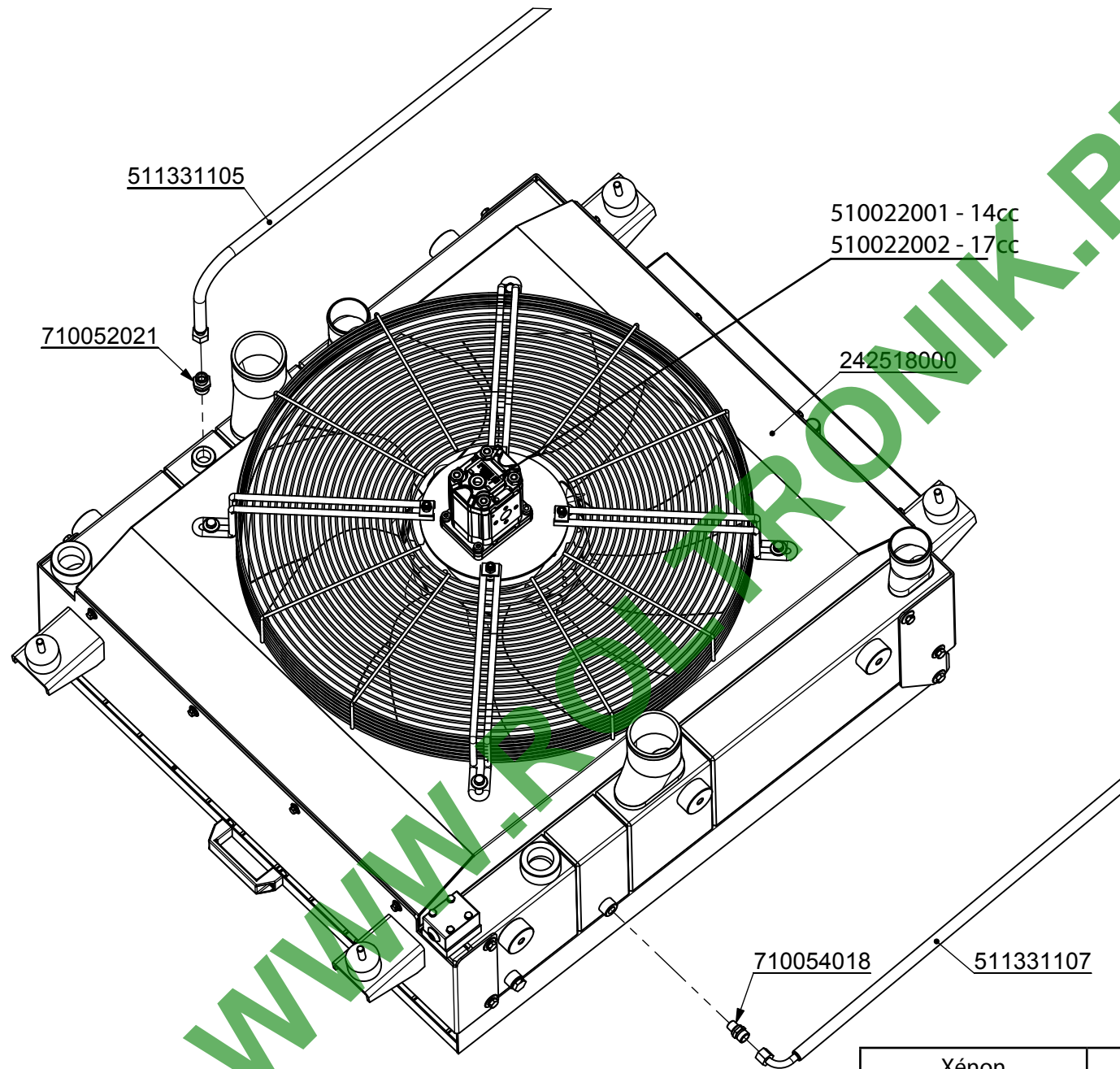

Xénon	Refroidissement boite Tier IIIB	26.11.2012
Mathot	239647000	Chap. 02
		P. 15