

Xénon	Réservoir à carburant / Fuel Tank	12.04.2012
Mathot	242321000	Chap. 03
		P. 1

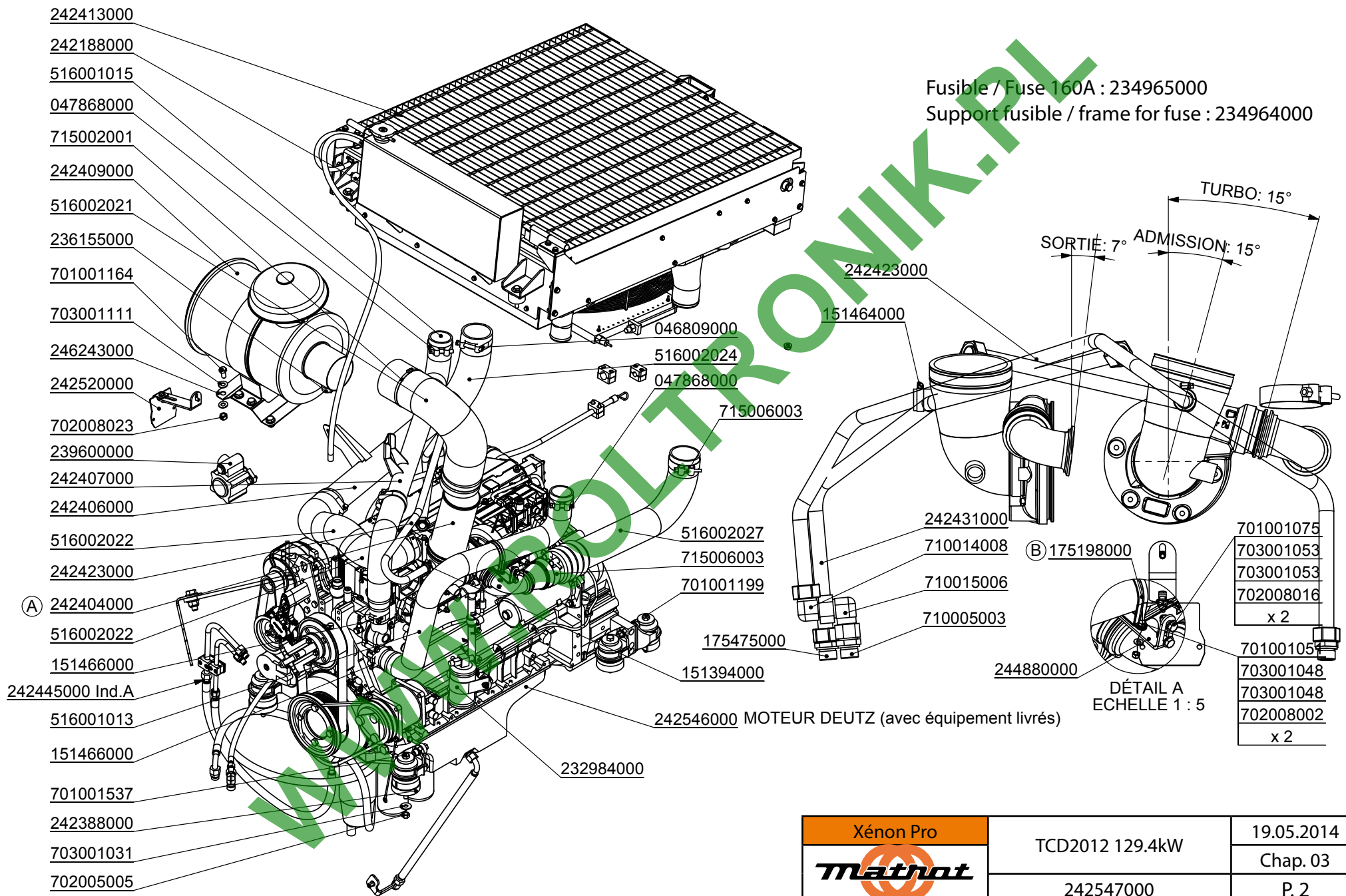

Fusible / Fuse 160A : 234965000
 Support fusible / frame for fuse : 234964000

	TCD2012 129.4kW	19.05.2014
	242547000	Chap. 03
		P. 2

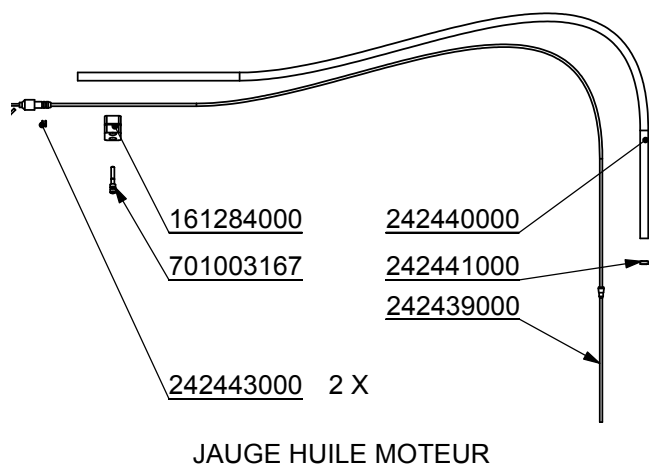

RALLONGE VIDANGE HUILE MOTEUR

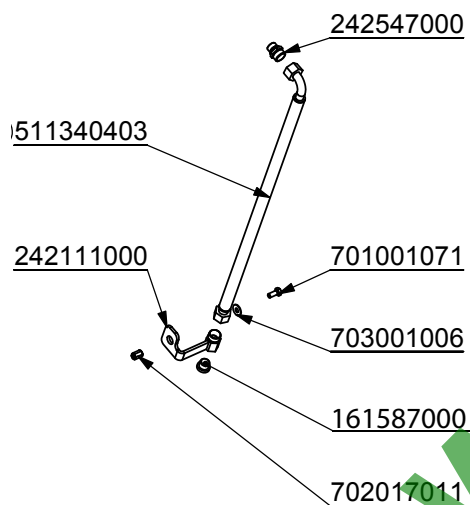

x4
 702008019
 703001039

JAUGE A HUILE

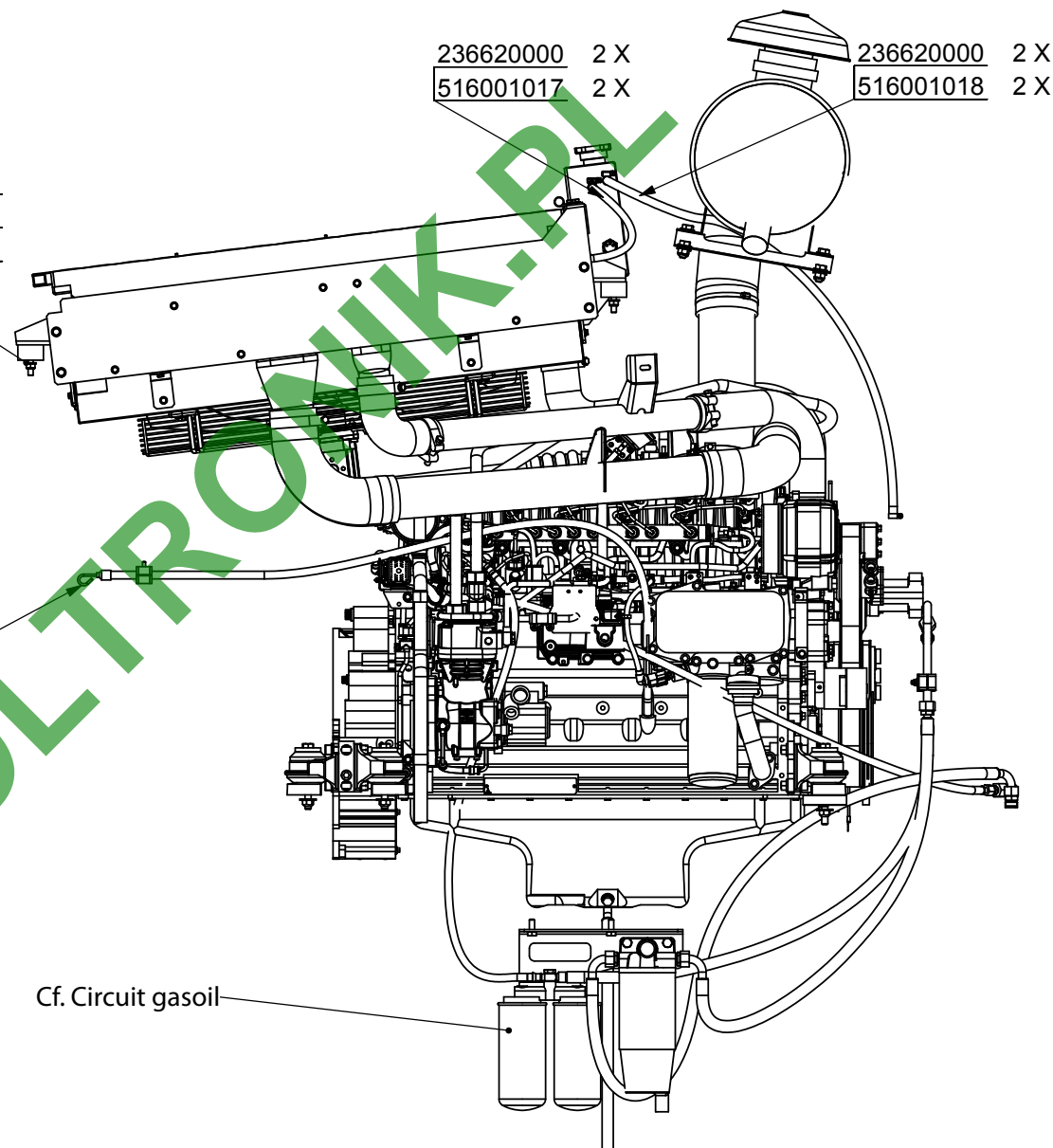

WWW.ROLTRONIK.PL

Xénon Pro	TCD2012 129.4kW	19.05.2014
Mathot	242547000	Chap. 03
		P. 3

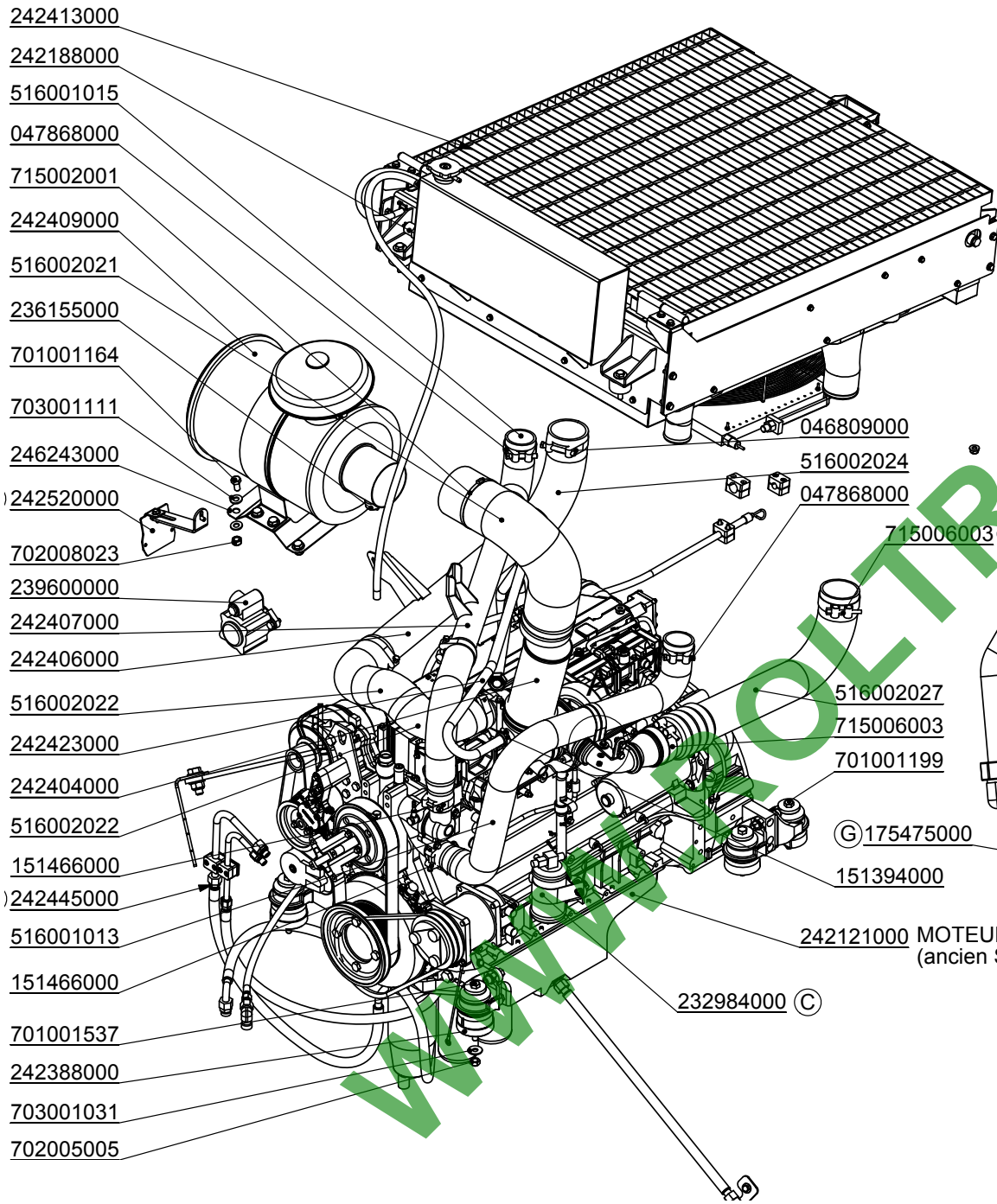

Fusible / Fuse 160A : 234965000
 Support fusible / frame for fuse : 234964000

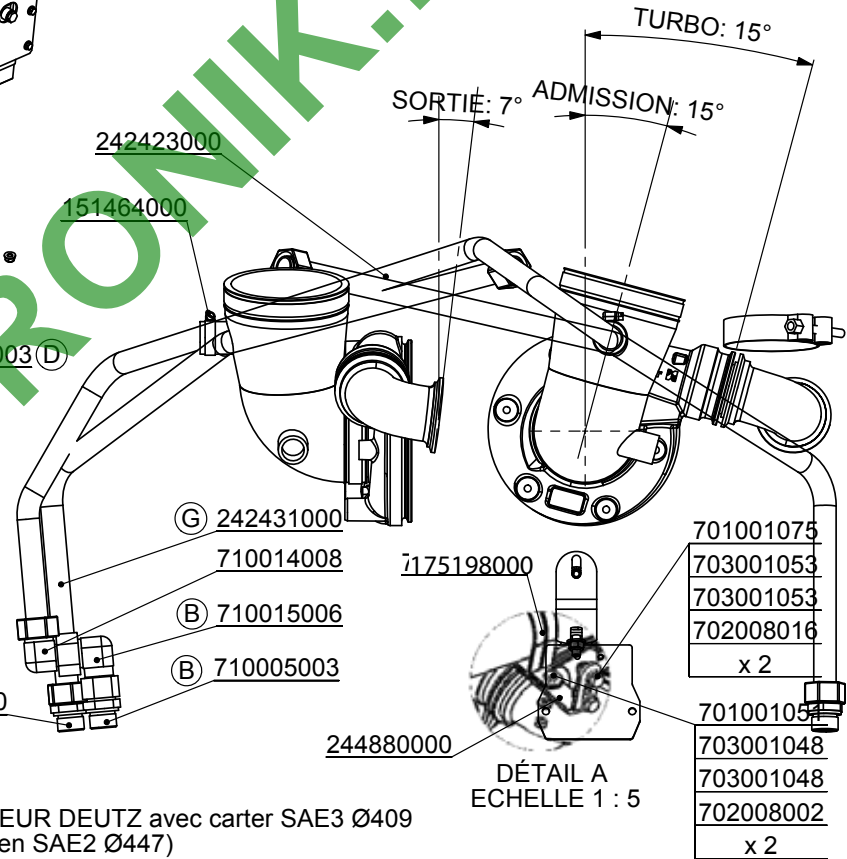

Xénon	TCD2012 155kw	19.05.2014
	242366000	Chap. 03
		P. 4

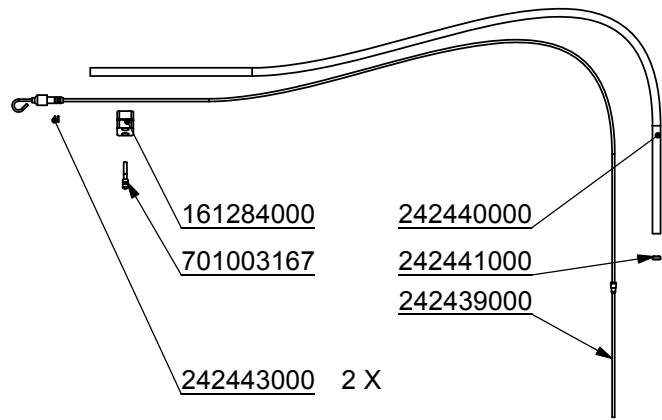

JAUGE HUILE MOTEUR ©

RALLONGE VIDANGE HUILE MOTEUR ©

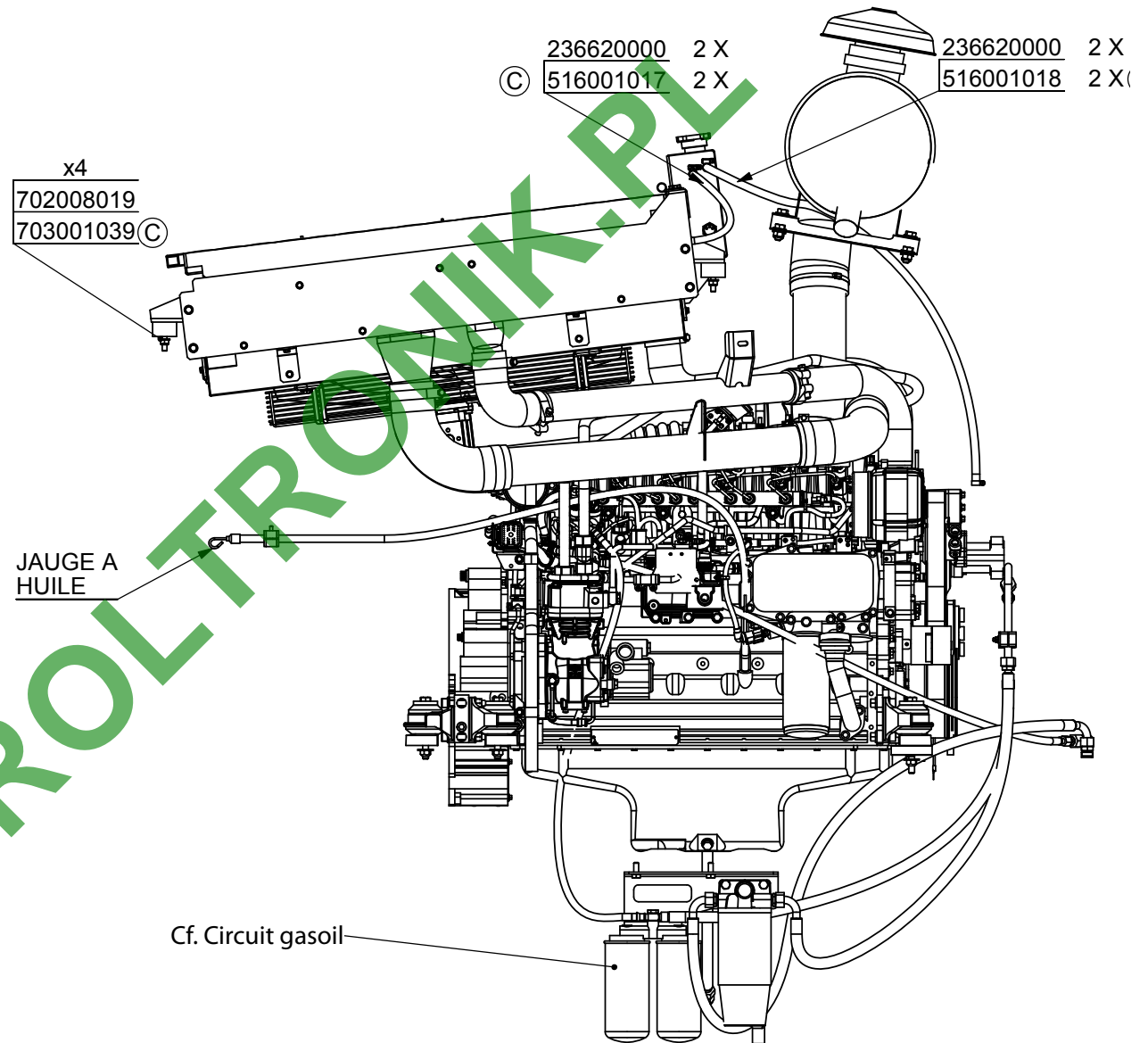
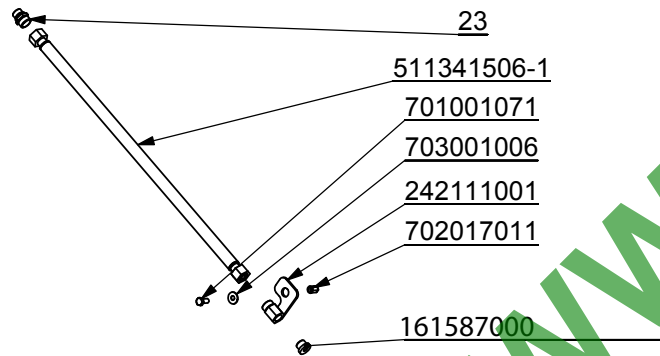

WWW.ROLTRONIK.PL

Xénon	155 kw Tier III A	19.05.2014
	242366000	Chap. 03
		P. 5

242412000
 242188000
 516001015
 047868000
 715002004
 242398000
 516002016
 236155000
 701001145
 703001111
 702008023
 242520000
 239600000
 242405000
 242331000
 715002001
 516002023
 242411000
 242404000
 516001014
 151466000
 516001016
 151466000
 701001537
 242445000
 242388000
 703001031
 702005005

Fusible / Fuse 160A : 234965000
 Support fusible / frame for fuse : 234964000

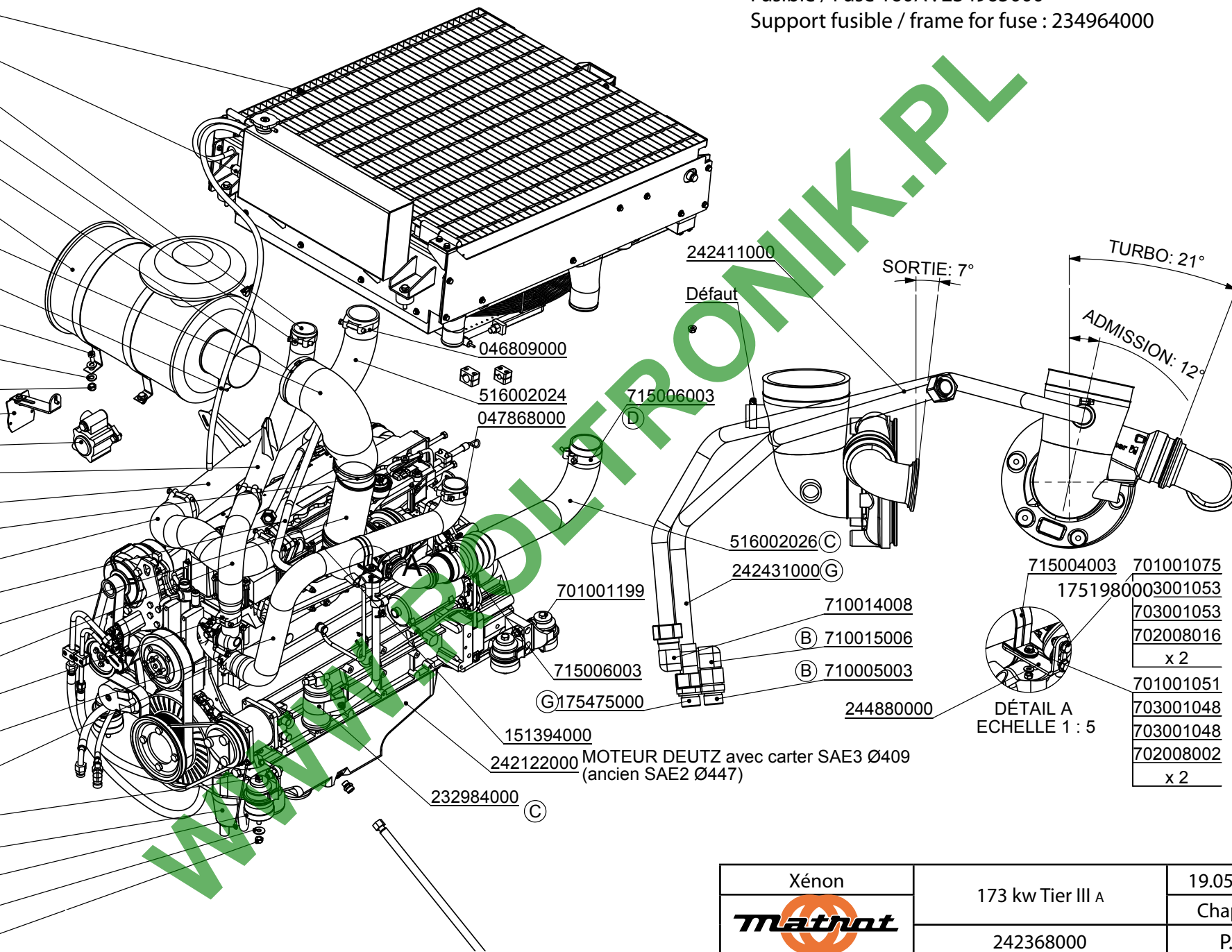

- 715004003
- 701001075
- 175198000
- 703001053
- 703001053
- 702008016
- x 2
- 701001051
- 703001048
- 703001048
- 702008002
- x 2

Xénon	173 kw Tier III A	19.05.2014
	242368000	Chap. 03
		P. 6

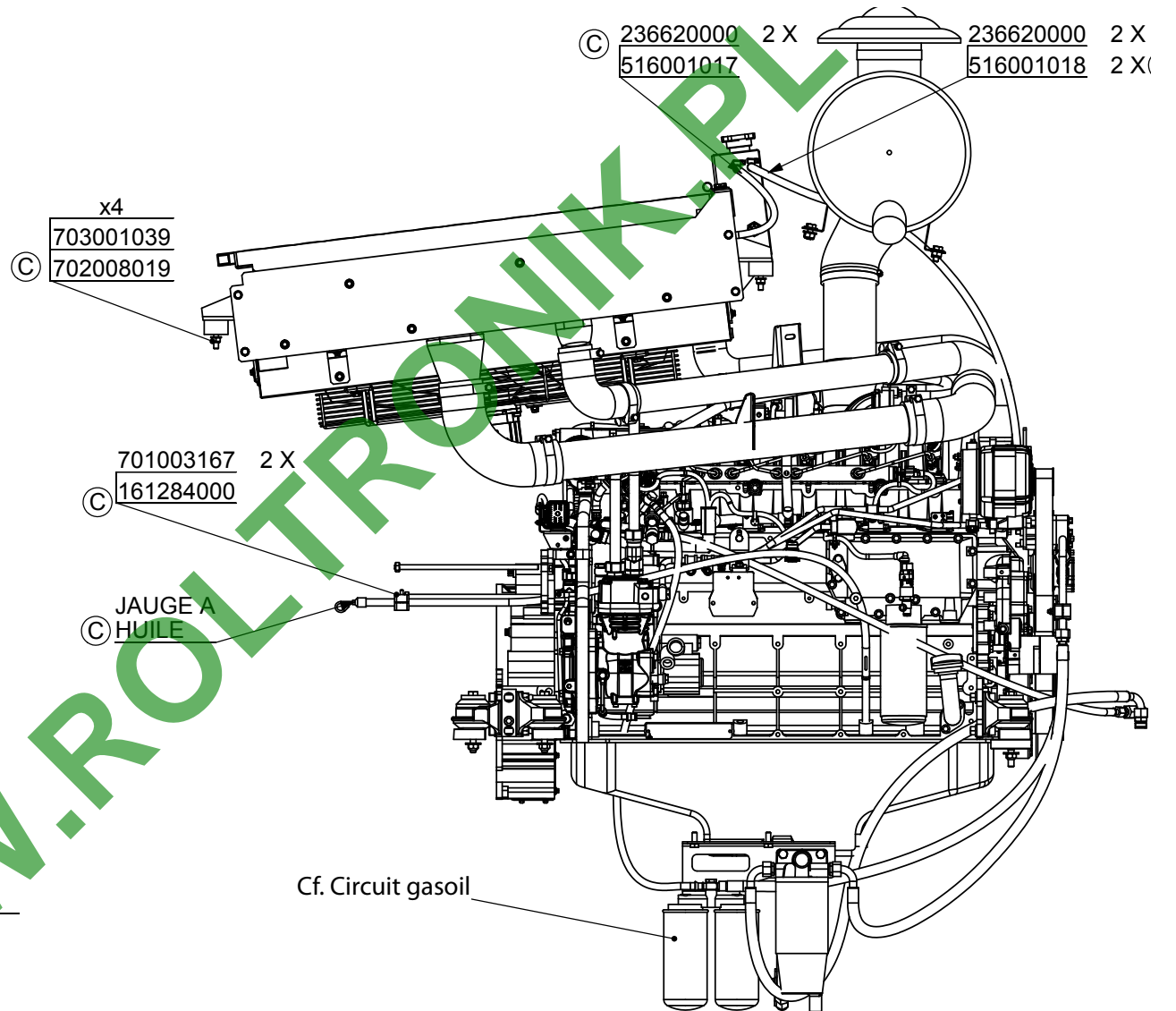
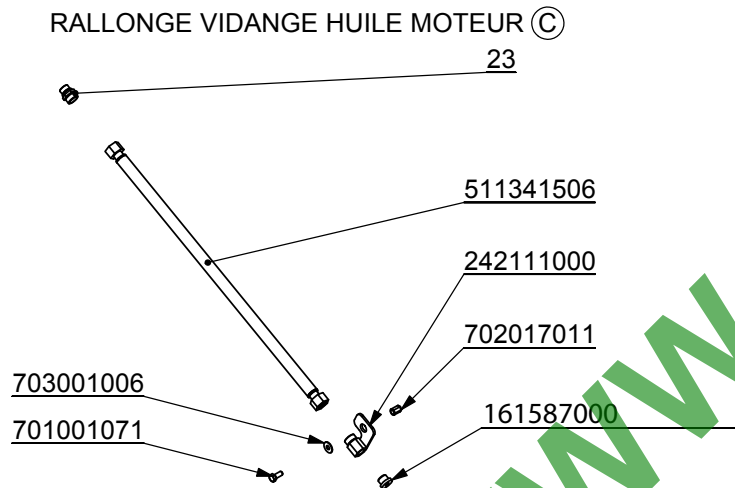
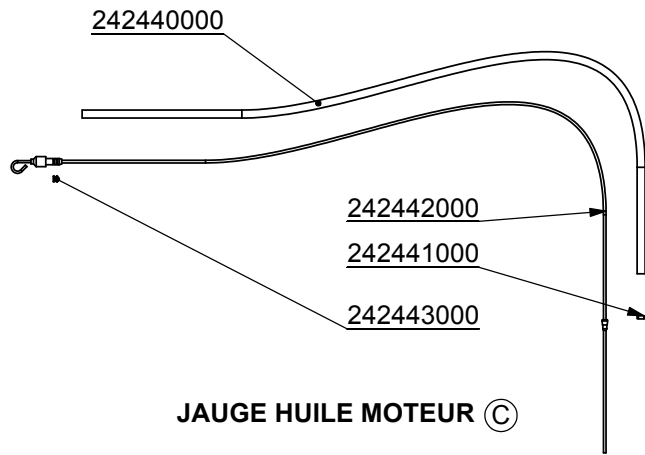

Xénon	173 kw Tier III A	19.05.2014
Mathot	242368000	Chap. 03
		P. 7

245471000
ENSEMBLE ISOLATION RADIATEUR □

242513000
CIRCUIT CHAUFFAGE CABINE TIER 3B

242374000
ECHAPPEMENT EQUIPE

239634000
KIT REFROIDISSEMENT
BOITE DE VITESSE TIER 3A

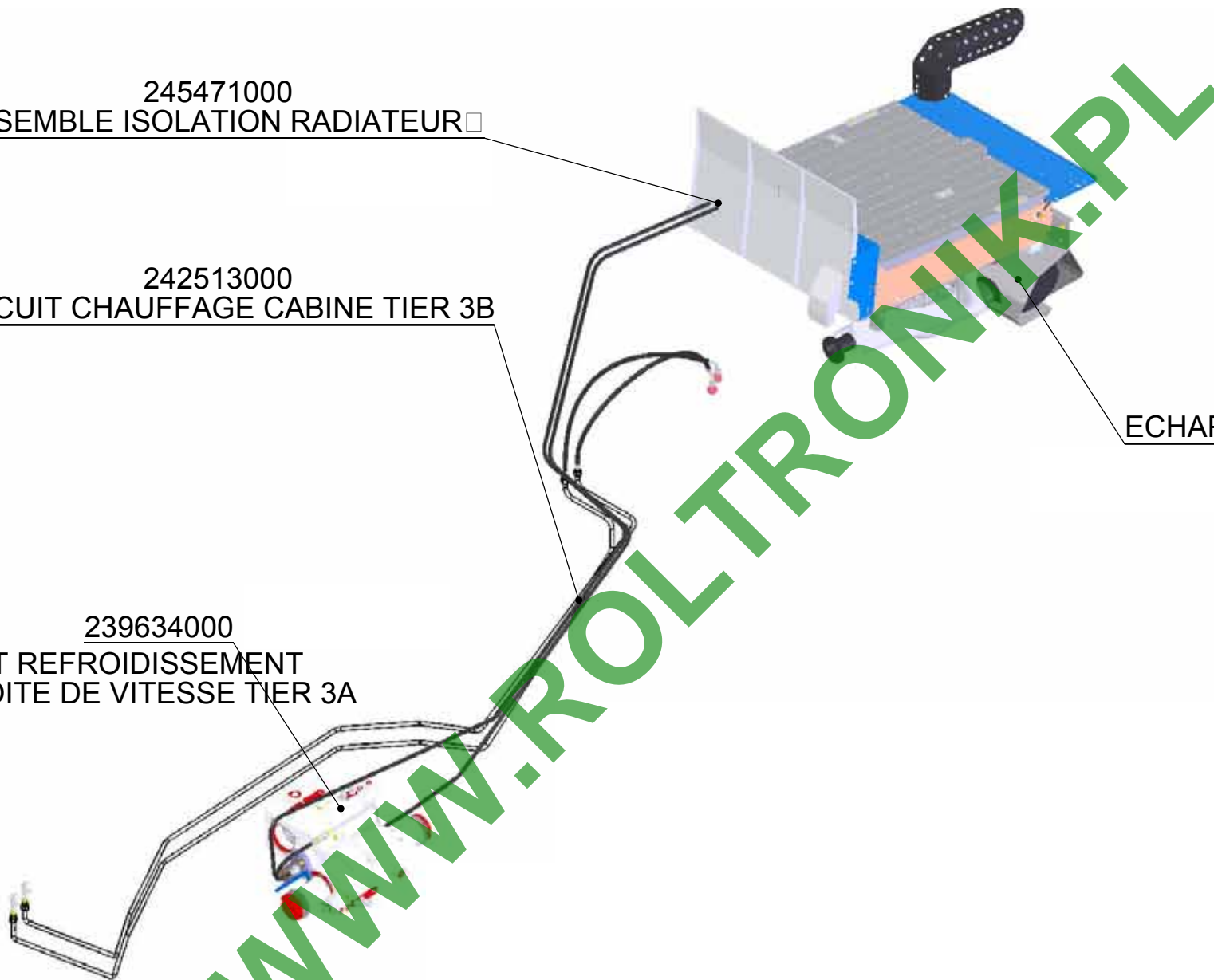

Xénon	Equipements Tier III A	23.11.2012
		Chap. 03
	242517000	P. 8

/E
T

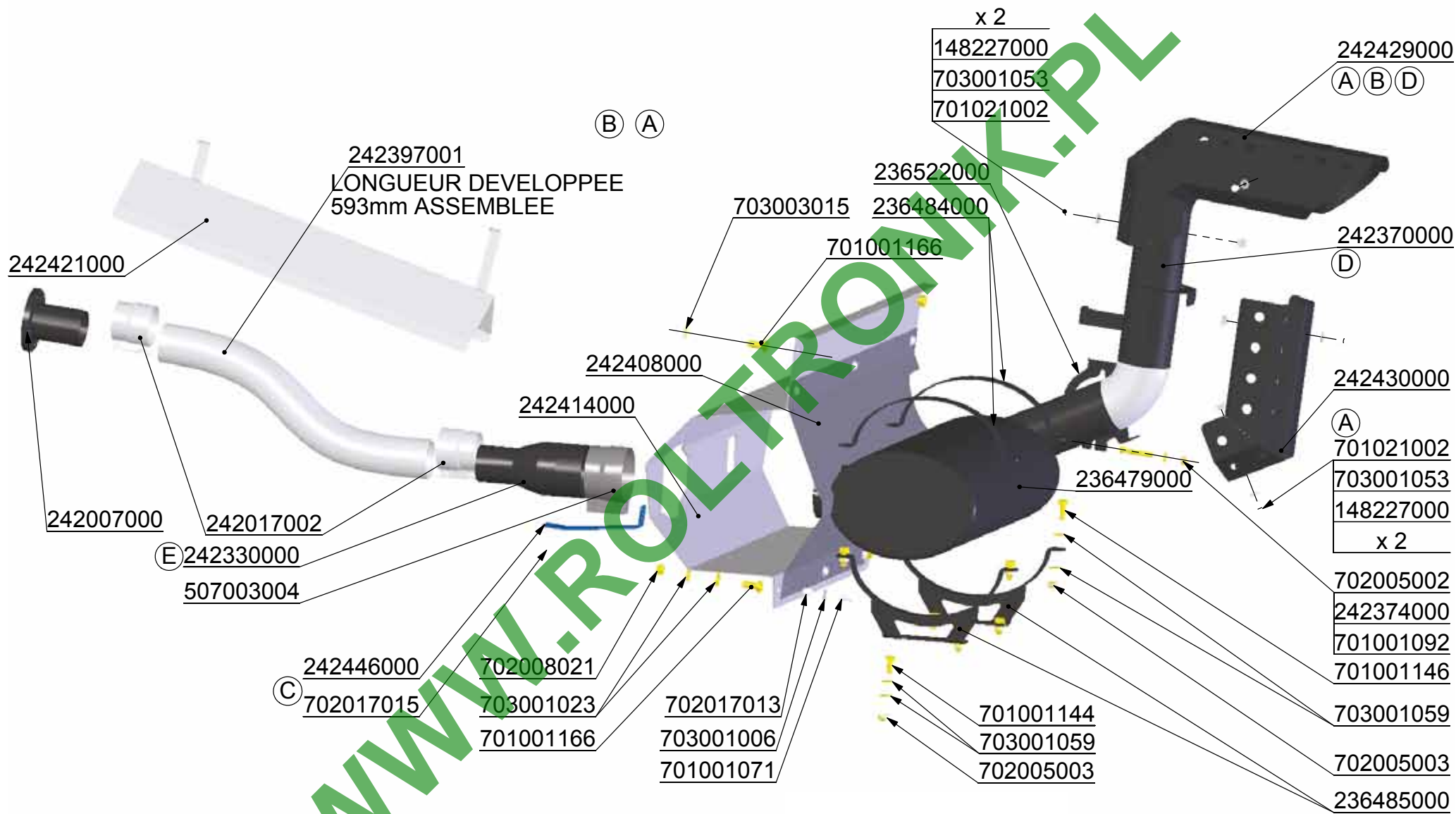

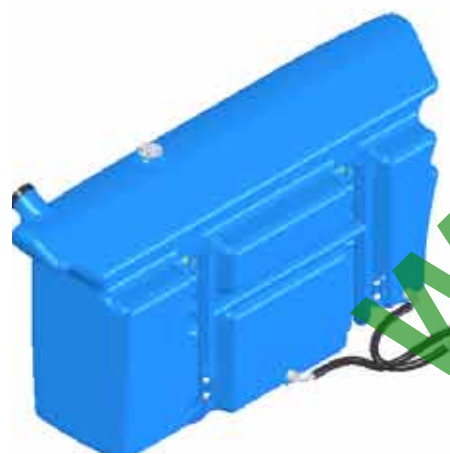
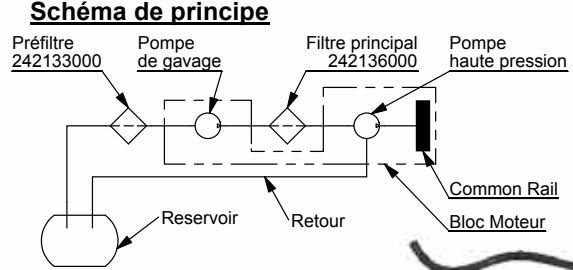
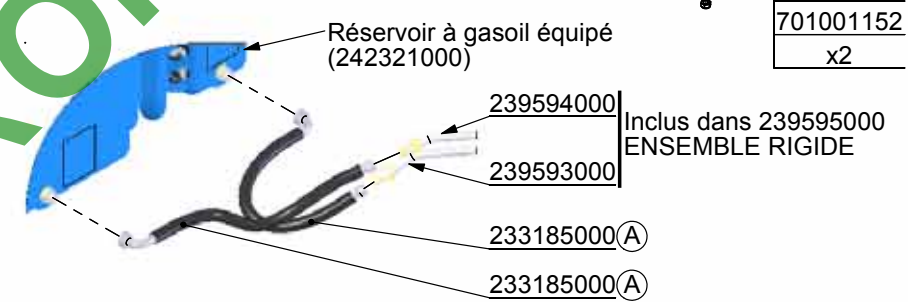
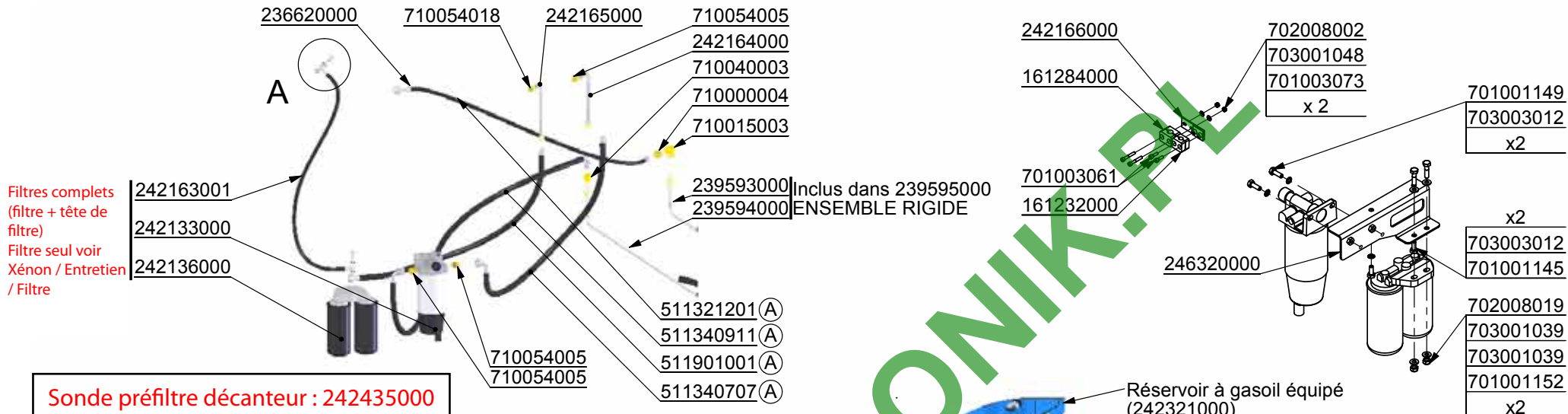

WWW.ROLTRONIK.PL

Xénon	Echappement Tier III A	17.04.2012
Matrot		Chap. 03
	242374000	P. 9

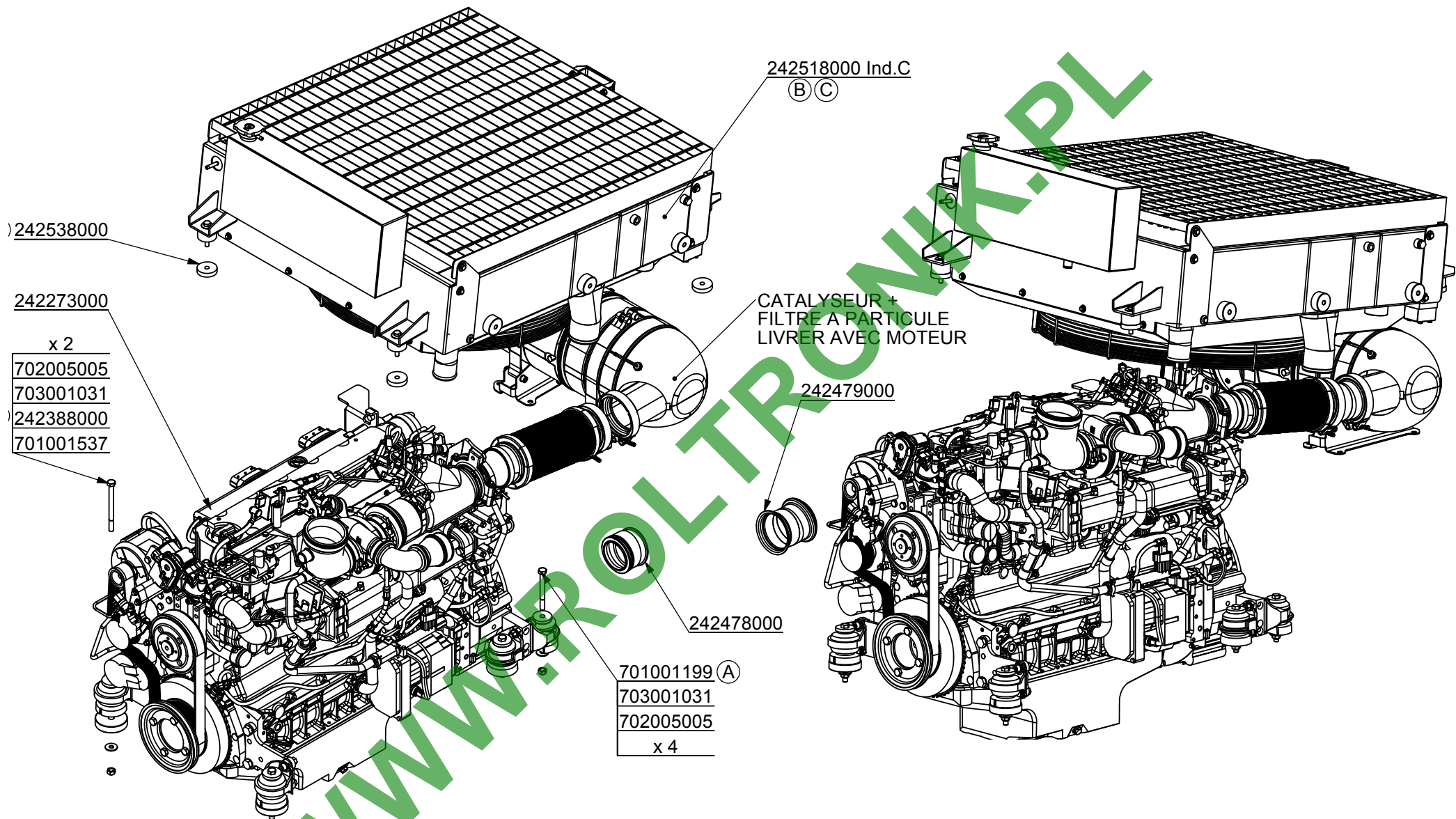

Xénon	Circuit Gasoil Tier III A	01.03.2012
Mathot		Chap. 03
	242445000	P. 10



Xénon	160 kw Tier III B	22.11.2012
	242454000	Chap. 03
		P. 11

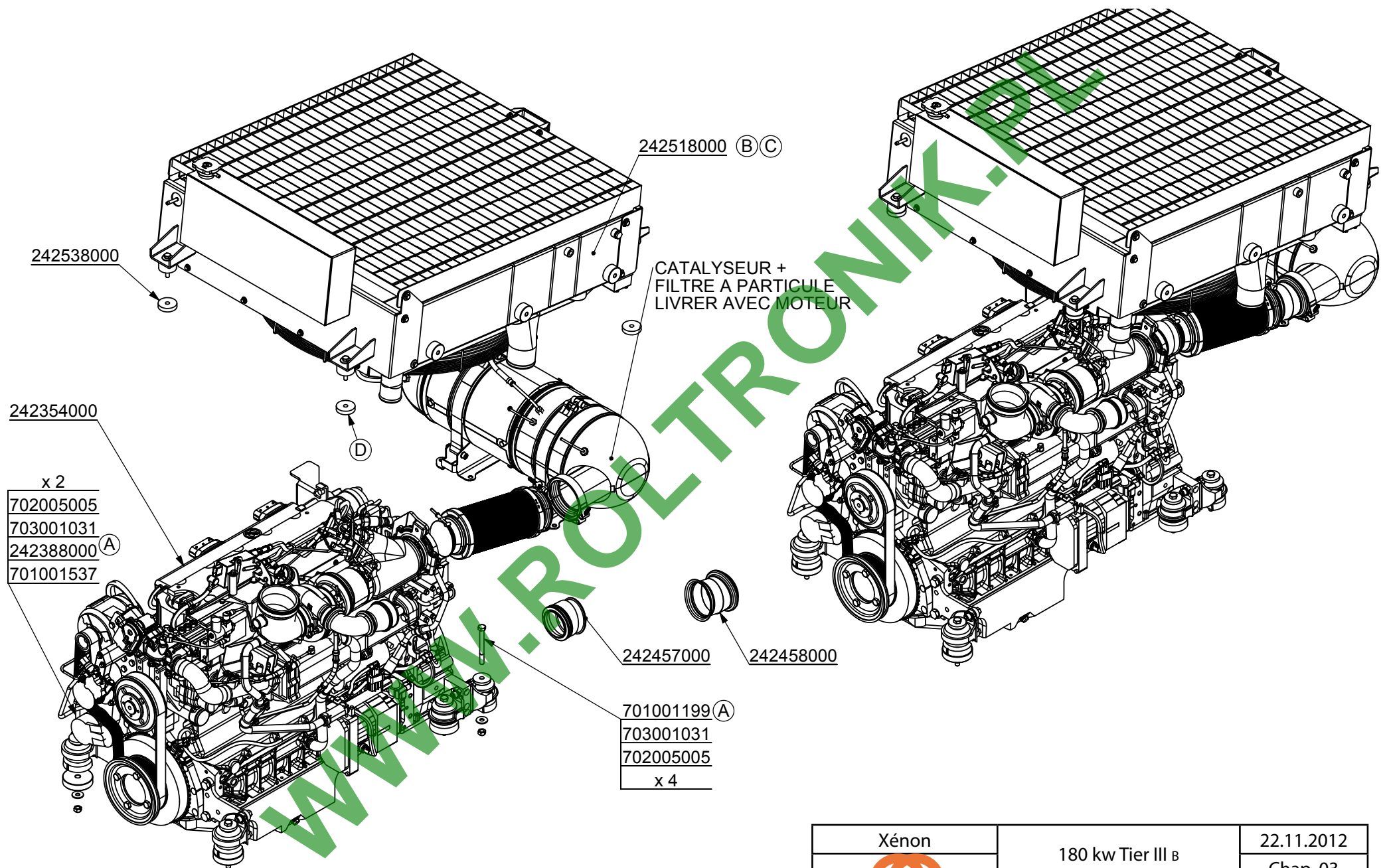

Xénon	180 kw Tier III B	22.11.2012
Mathot	242453000	Chap. 03
		P. 12

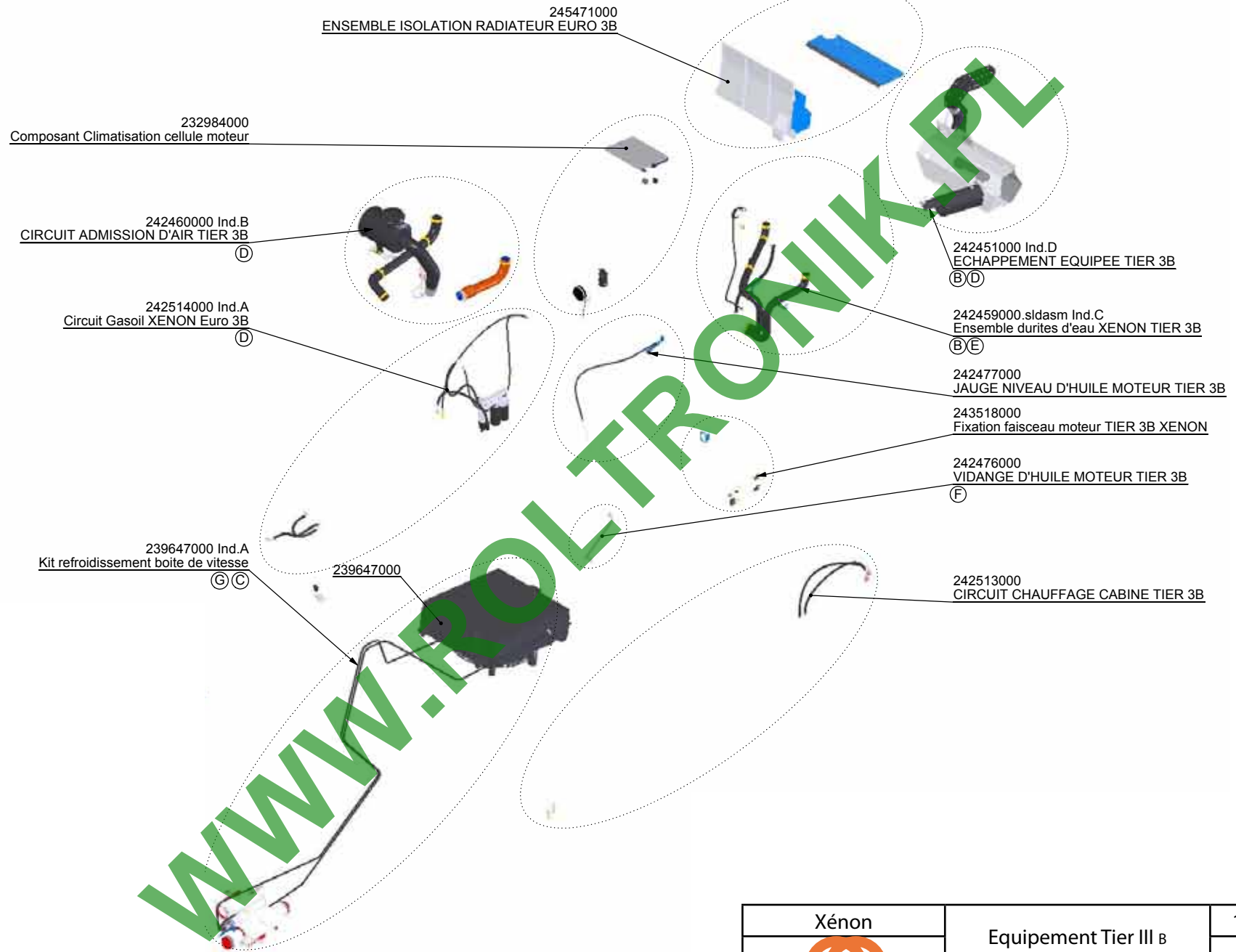

Xénon	Equipement Tier III B	16.09.2014
Mathot		Chap. 03
	242452000	P. 13

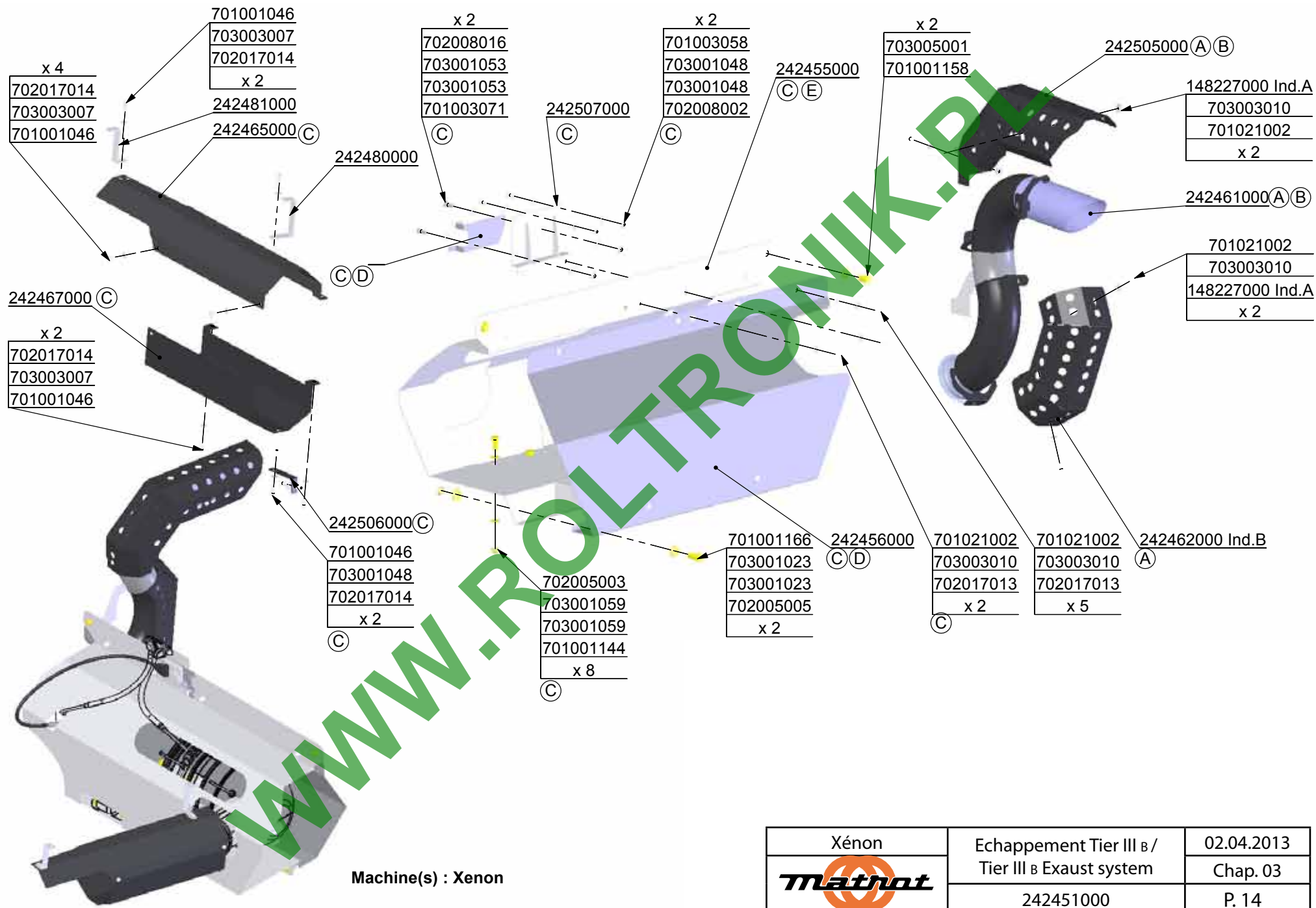

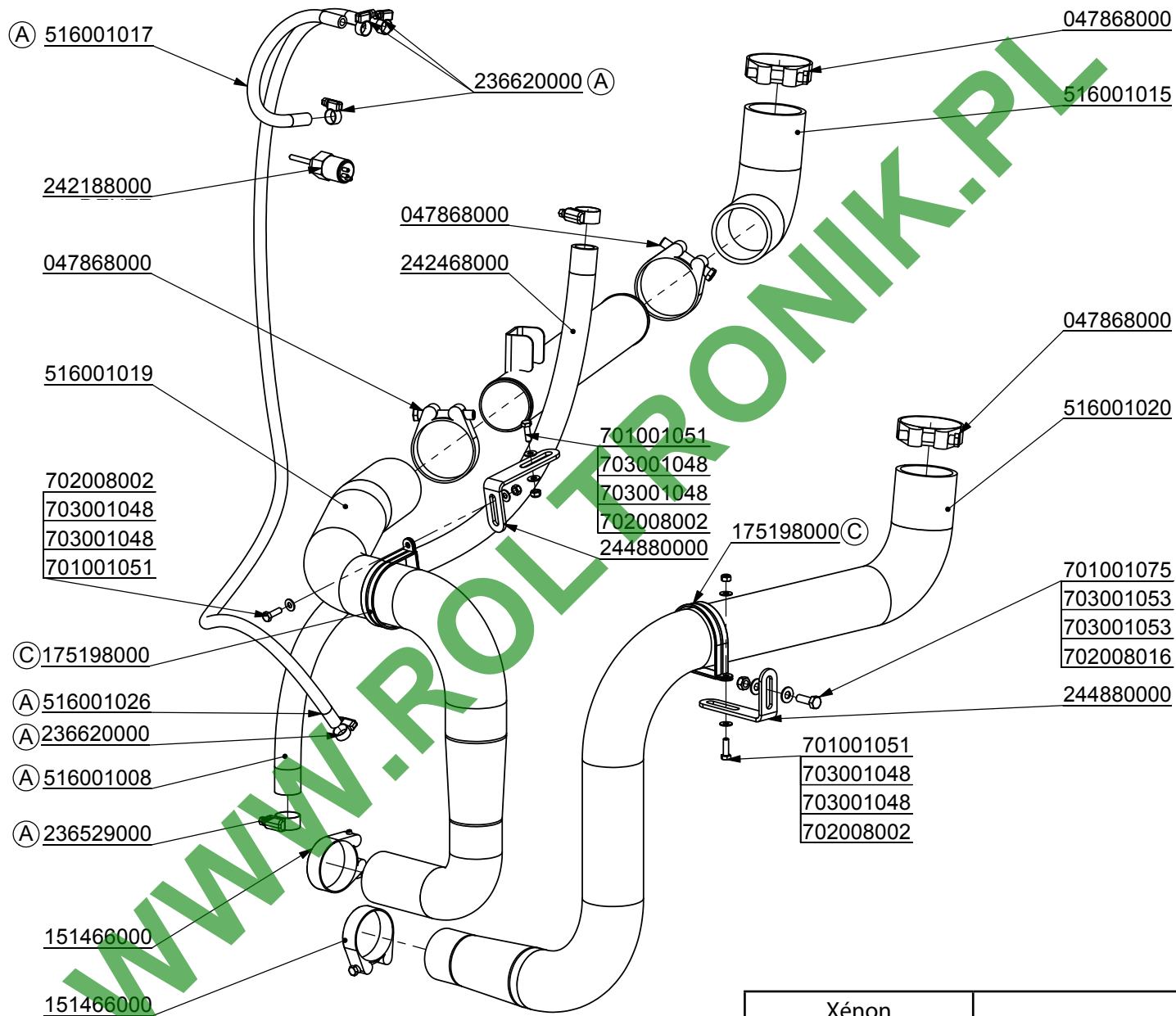

Xénon	Echappement Tier III B / Tier III B Exhaust system	02.04.2013
		Chap. 03
	242451000	P. 14



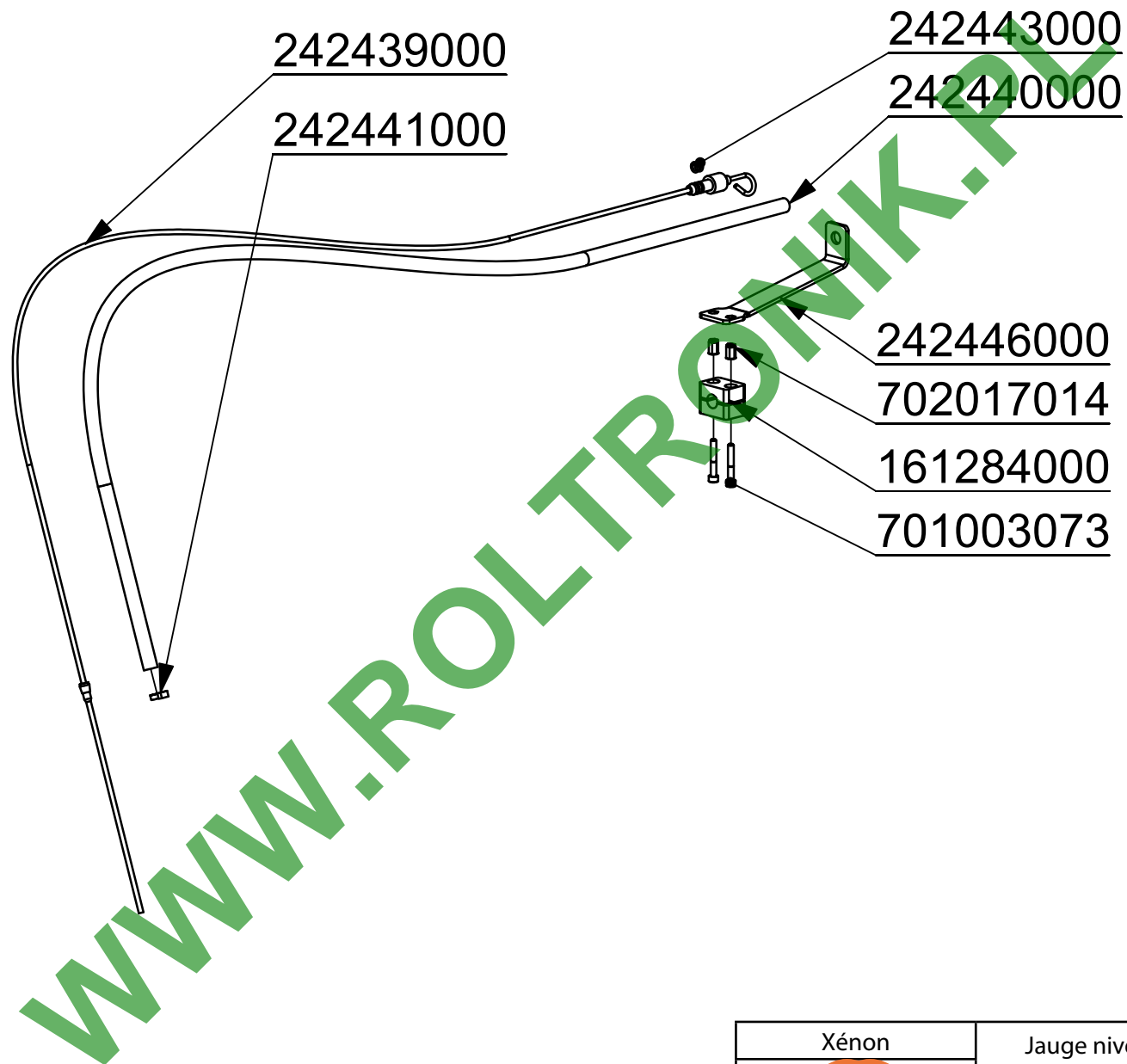

APPROU

Xénon	Durites d'eau Tier III B	29.10.2012
Mathot		Chap. 03
	242459000	P. 15

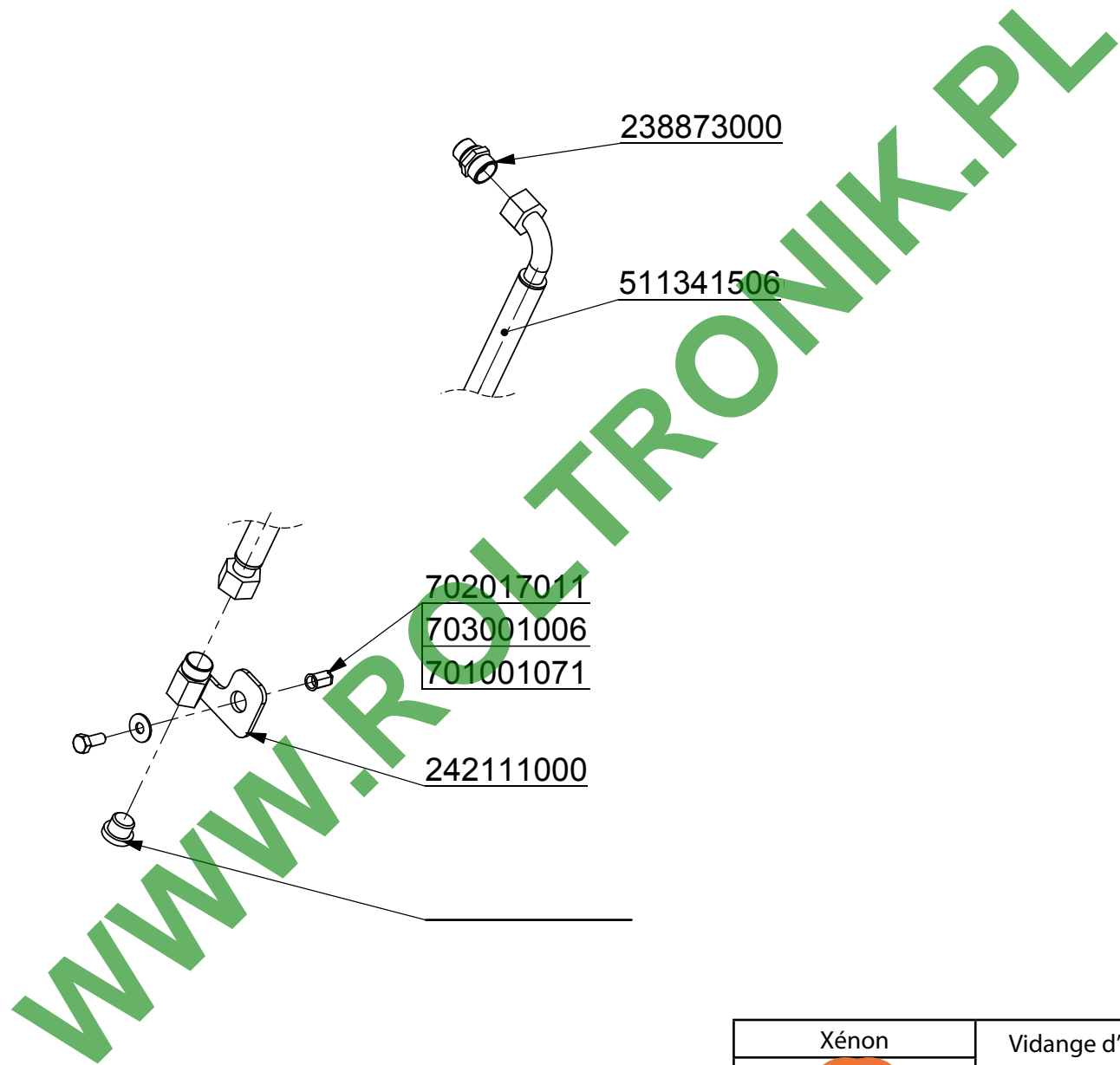

Xénon	Jauge niveau d'huile	26.07.2011
	Tier III B	Chap. 03
	242477000	P. 16



Xénon	Vidange d'huile moteur	19.09.2014
	Tier III B	Chap. 03
	242476000	P. 17

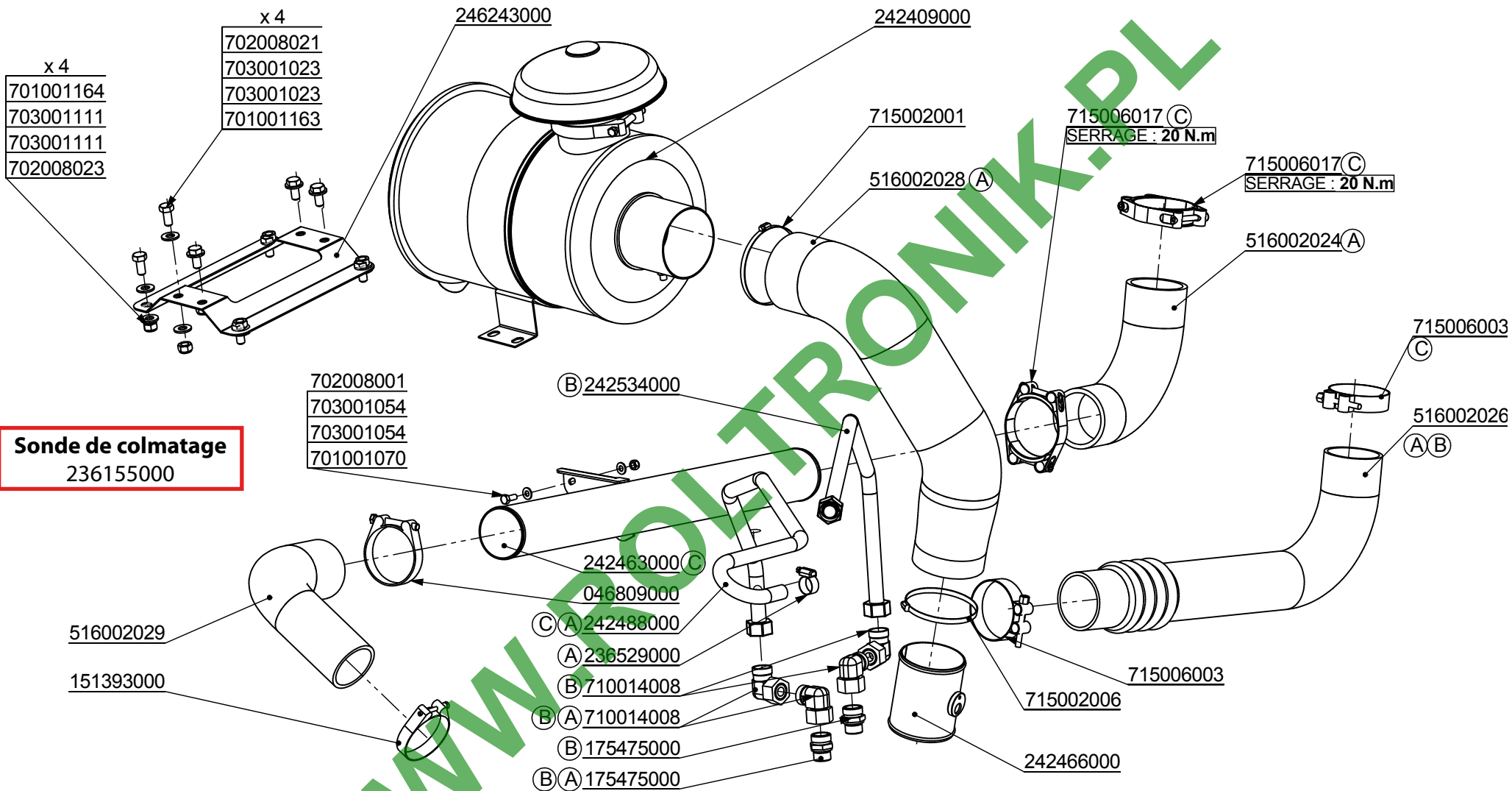

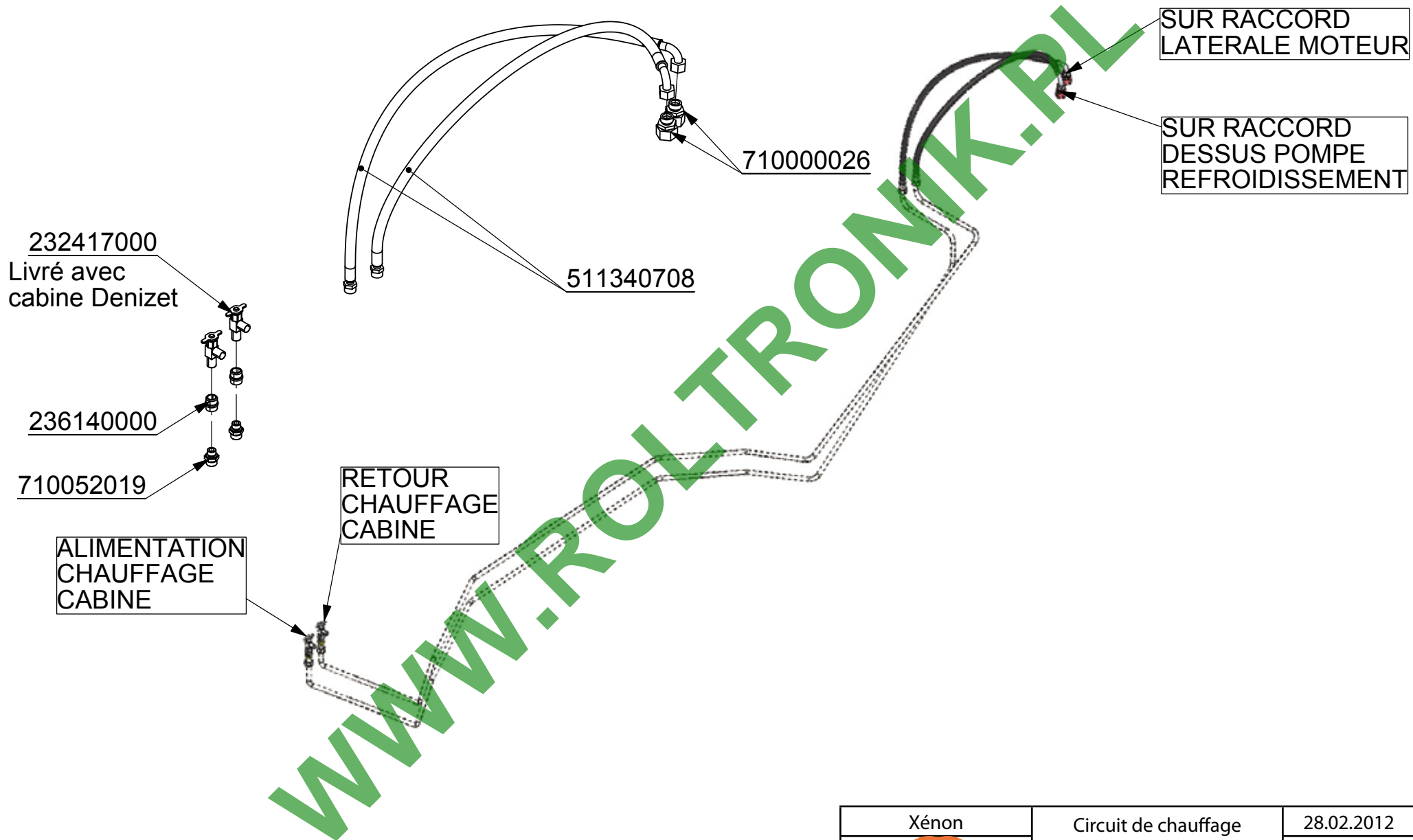

WWW.MATHOT.ELECTRONIK.PL

Xénon	Circuit admission d'air Tier III B	02.12.2013
	242460000	Chap. 03 P. 18

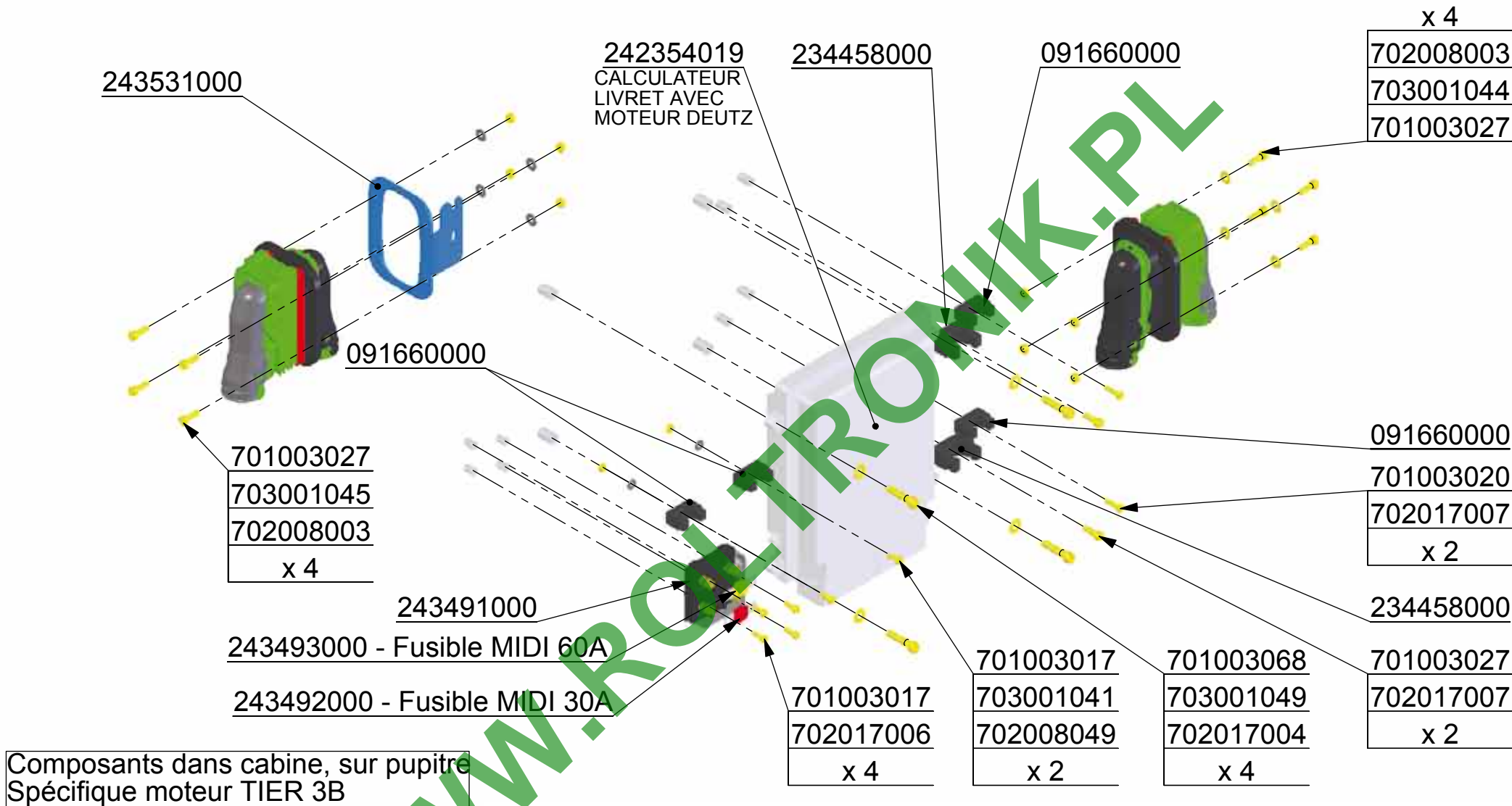

Xénon	Circuit de chauffage Tier III B	28.02.2012
	242513000	Chap. 03
		P. 19



Xénon	Fixation faisceau moteur Tier III B	28.02.2012
		Chap. 03
	243518000	P. 20

232415000

x 4

- 702008051
- 703001042
- 703001042
- 701003267



Schéma de principe

161302000

161284000

701003065 4 x

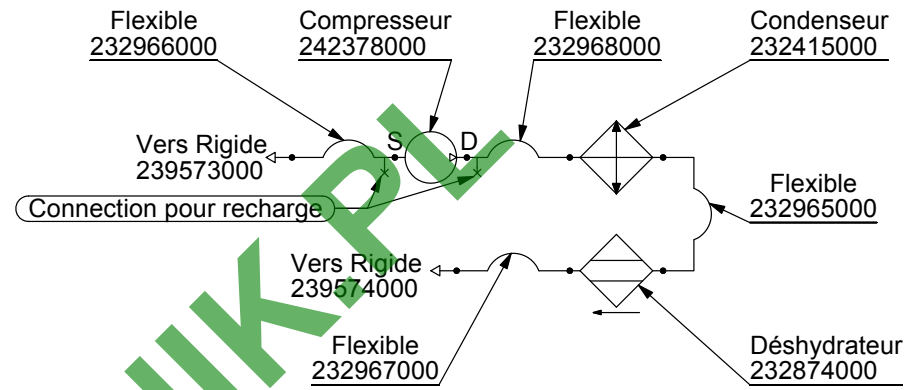
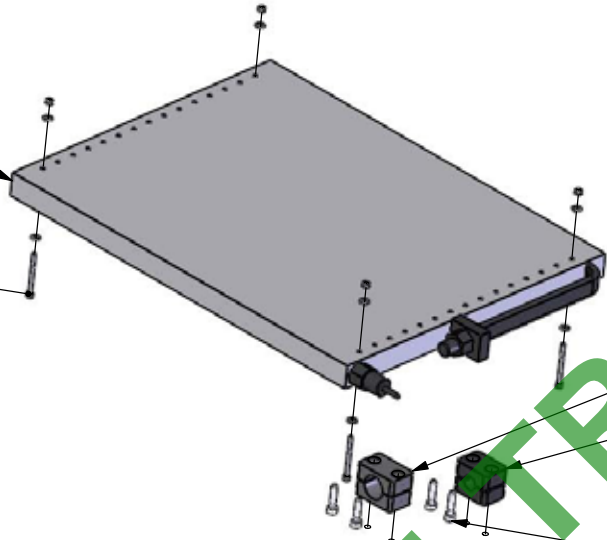
232874000

232874001

232378000

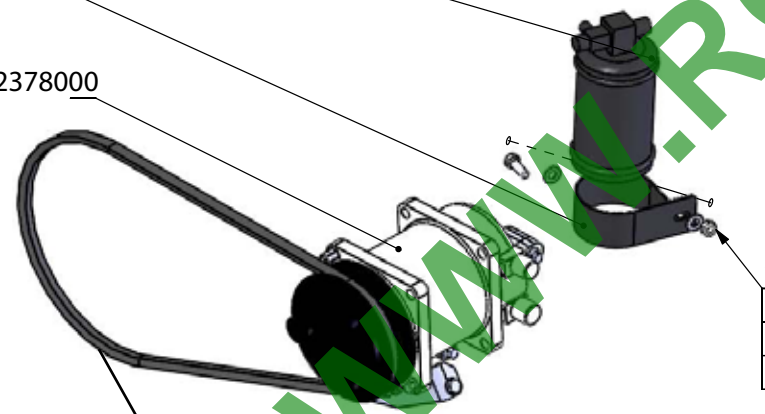

- 702008016
- 703001053
- 703001053
- 701001075

236559000

Flexible Climatisation	
232966000	compresseur - rigide M10
232965000	condenseur - deshydrateur
232967000	deshydrateur - rigide M6
232968000	compresseur - condenseur

Xénon	Composants climatisation	25.05.2011
	Tier III B	Chap. 03
	232984000	P. 21

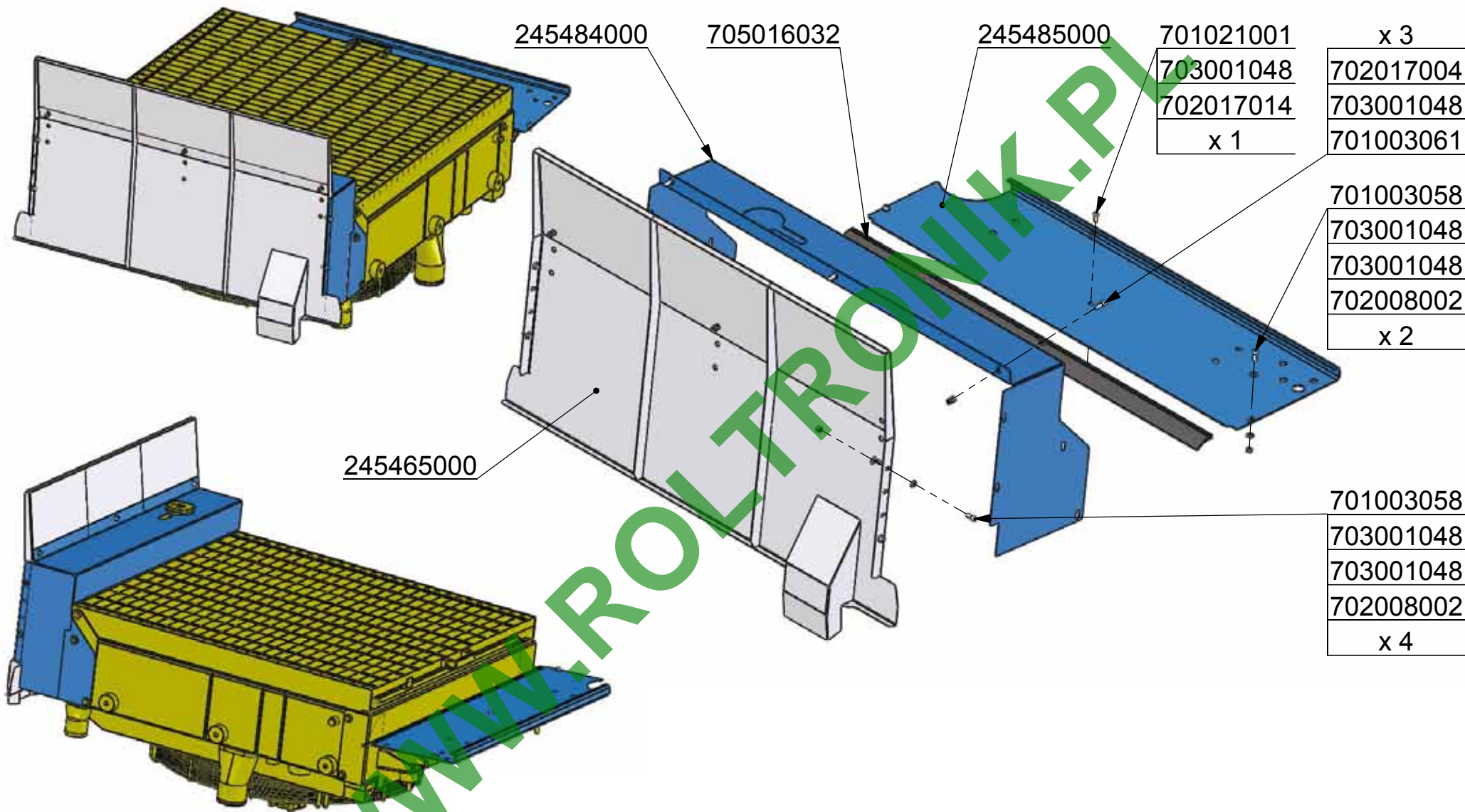

WWW.ROLTRONIK.PL

Xénon	Ensemble isolation	17.01.2012
	Tier III B	Chap. 03
	245483000	P. 22

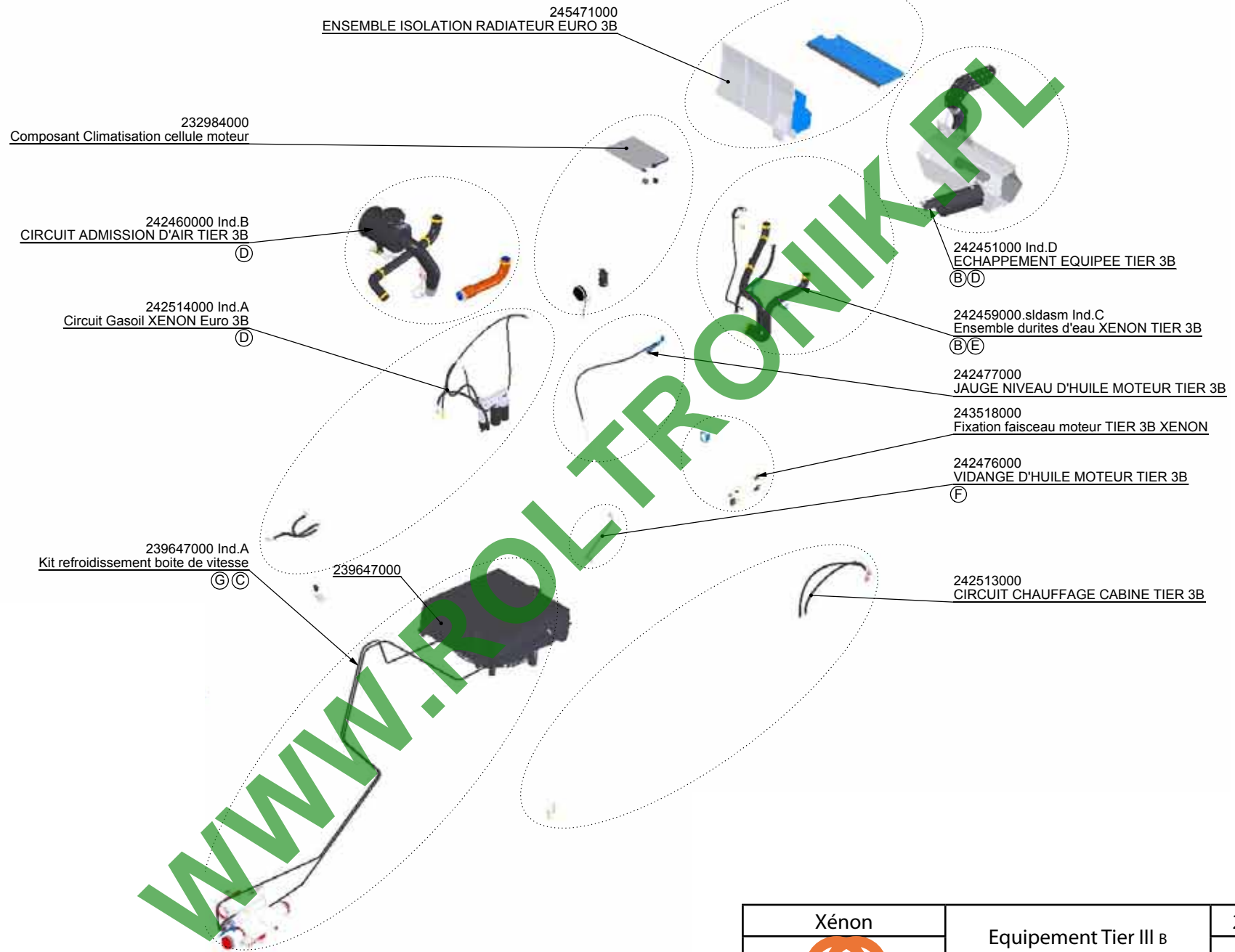

Xénon	Equipement Tier III B	26.11.2012
Mathot		Chap. 03
	242452000	P. 23



Filtres complets
(filtre + tête de
filtre)
Filtre seul voir
Xénon / Entretien
/ Filtre

- 242163000
- 242163000
- 242133000
- 242136000

236620000

511321202 (A)

A

- 511901601
- 710040003
- 710000004
- 710015003

239593000 Inklus dans 239595000
239594000 ENSEMBLE RIGIDE

710054005

511340911

x 2
239611000
239222000
DÉTAIL A
ECHELLE 1 : 5

246320000

701001149
703003012
x2

x2
703003012
701001145

702008019
703001039
703001039
701001152
x2



Sonde préfiltre décanteur : 242435000

Schéma de principe

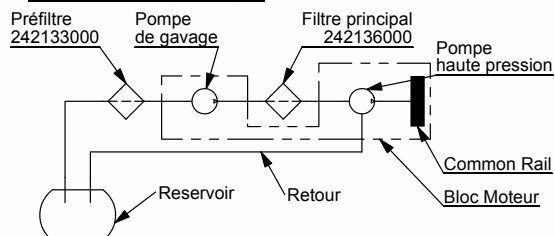

Réservoir à gasoil équipé
(242321000)

239594000 Inklus dans 239595000
239593000 ENSEMBLE RIGIDE

233185000

233185000



Xénon	Circuit Gasoil Tier III B	28.09.2012
		Chap. 03
	242514000	P. 24

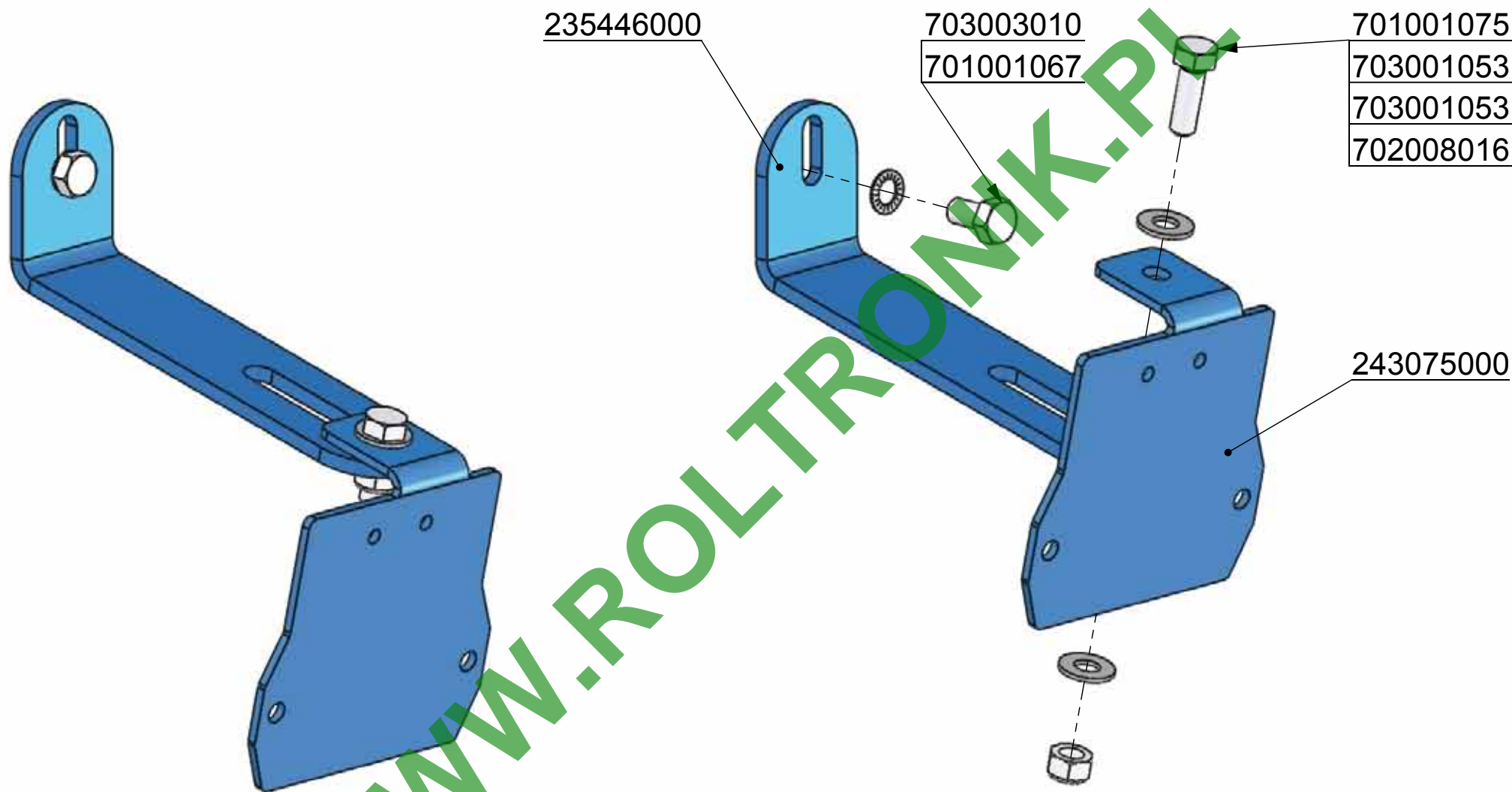

WWW.ROLTRONIK.PL

Xénon	Support relais de préchauffage	06.06.2012
Mathot	242520000	Chap. 03
		P. 25