

Modèles \ Km/h	25	40
17/39	X	X
17/40		X
21/39	X	X
21/40		X
23/45	X	

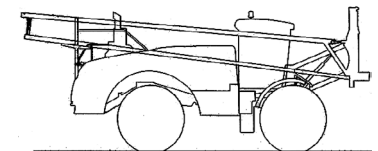

RÉSERVOIR HYDRAULIQUE ÉQUIPÉ
COMPLETE HYDRAULIC TANK

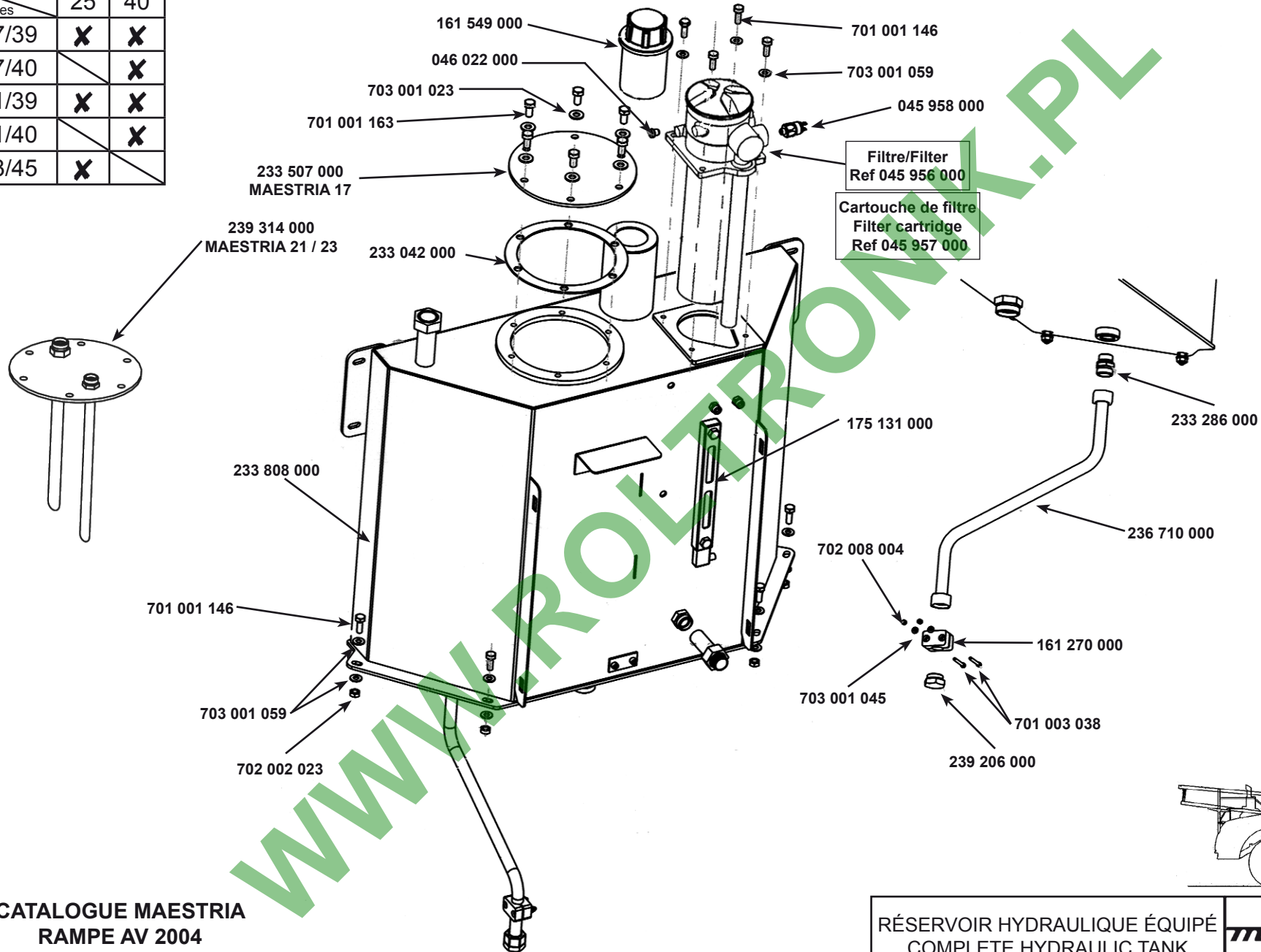

4
A01
09/12/04

Km/h	25	40
17/39	X	X
17/40		X
21/39	X	X
21/40		X
23/45		

- Rep 1 Ref 710 032 000
- Rep 2 Ref 233 876 000
- Rep 3 Ref 233 399 000
- Rep 4 Ref 239 035 000
- Rep 5 Ref 703 004 003
- Rep 6 Ref 161 290 000
- Rep 7 Ref 233 024 000
- Rep 8 Ref 175 125 000
- Rep 9 Ref 046 488 000

- Rep10 Ref 175 010 000
- Rep11 Ref 239 417 000
- Rep12 Ref 233 880 000
- Rep13 Ref 711 014 008
- Rep14 Ref 239 417 000
- Rep15 Ref 710 040 001
- Rep16 Ref 511 350 301
- Rep17 Ref 511 360 201
- Rep18 Ref 701 003 068
- Rep19 Ref 511 660 001
- Rep20 Ref 233 403 000

**CATALOGUE MAESTRIA
RAMPE AV 2004**

Correctif mars 2009/March 2009 correction

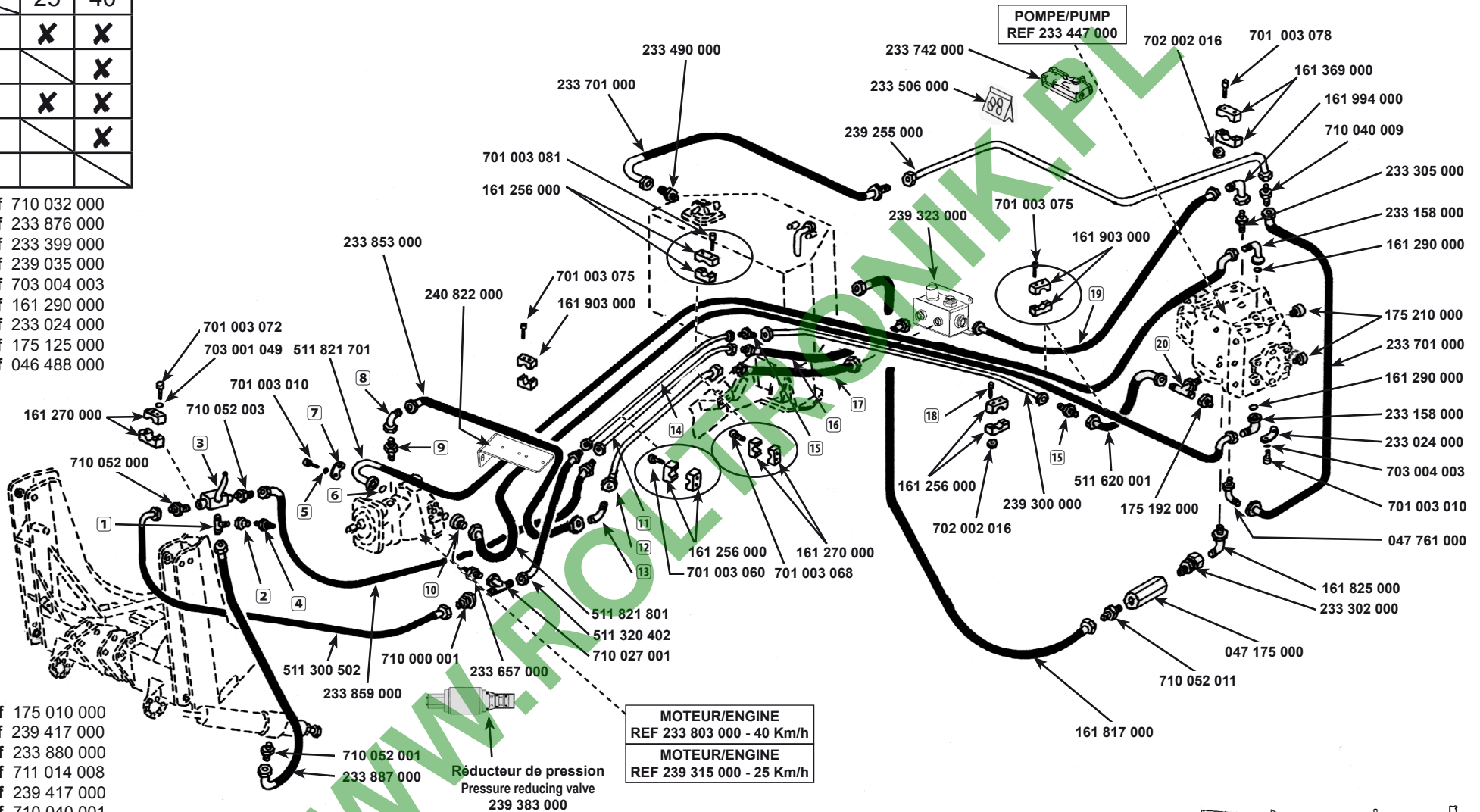

Km/h	25	40
17/39	X	X
17/40		X
21/39	X	X
21/40		X
23/45		

Rep 15	Réf	233 859 000	Rep 31	Réf	710 014 008
Rep 16	Réf	233 657 000	Rep 32	Réf	239 323 000
Rep 17	Réf	233 504 000	Rep 33	Réf	511 360 201
Rep 18	Réf	046 488 000	Rep 34	Réf	701 003 068
Rep 19	Réf	710 000 001	Rep 35	Réf	161 270 000
Rep 20	Réf	701 027 001	Rep 36	Réf	047 175 000
Rep 21	Réf	711 014 008	Rep 37	Réf	710 052 011
Rep 22	Réf	233 880 000	Rep 38	Réf	701 003 068
Rep 23	Réf	701 003 060	Rep 39	Réf	511 620 001
Rep 24	Réf	161 256 000	Rep 40	Réf	233 403 000
Rep 25	Réf	239 301 000	Rep 41	Réf	175 192 000
Rep 26	Réf	233 880 000			
Rep 27	Réf	710 040 001			
Rep 28	Réf	511 360 201			
Rep 29	Réf	710 039 008			
Rep 30	Réf	233 302 000			

Rep 1	Réf	710 032 000
Rep 2	Réf	233 876 000
Rep 3	Réf	239 035 000
Rep 4	Réf	233 399 000
Rep 5	Réf	710 052 003
Rep 6	Réf	701 003 010
Rep 7	Réf	703 004 003
Rep 8	Réf	233 024 000
Rep 9	Réf	233 500 000
Rep 10	Réf	161 964 000
Rep 11	Réf	046 488 000
Rep 12	Réf	175 125 000
Rep 13	Réf	161 290 000
Rep 14	Réf	511 811 001

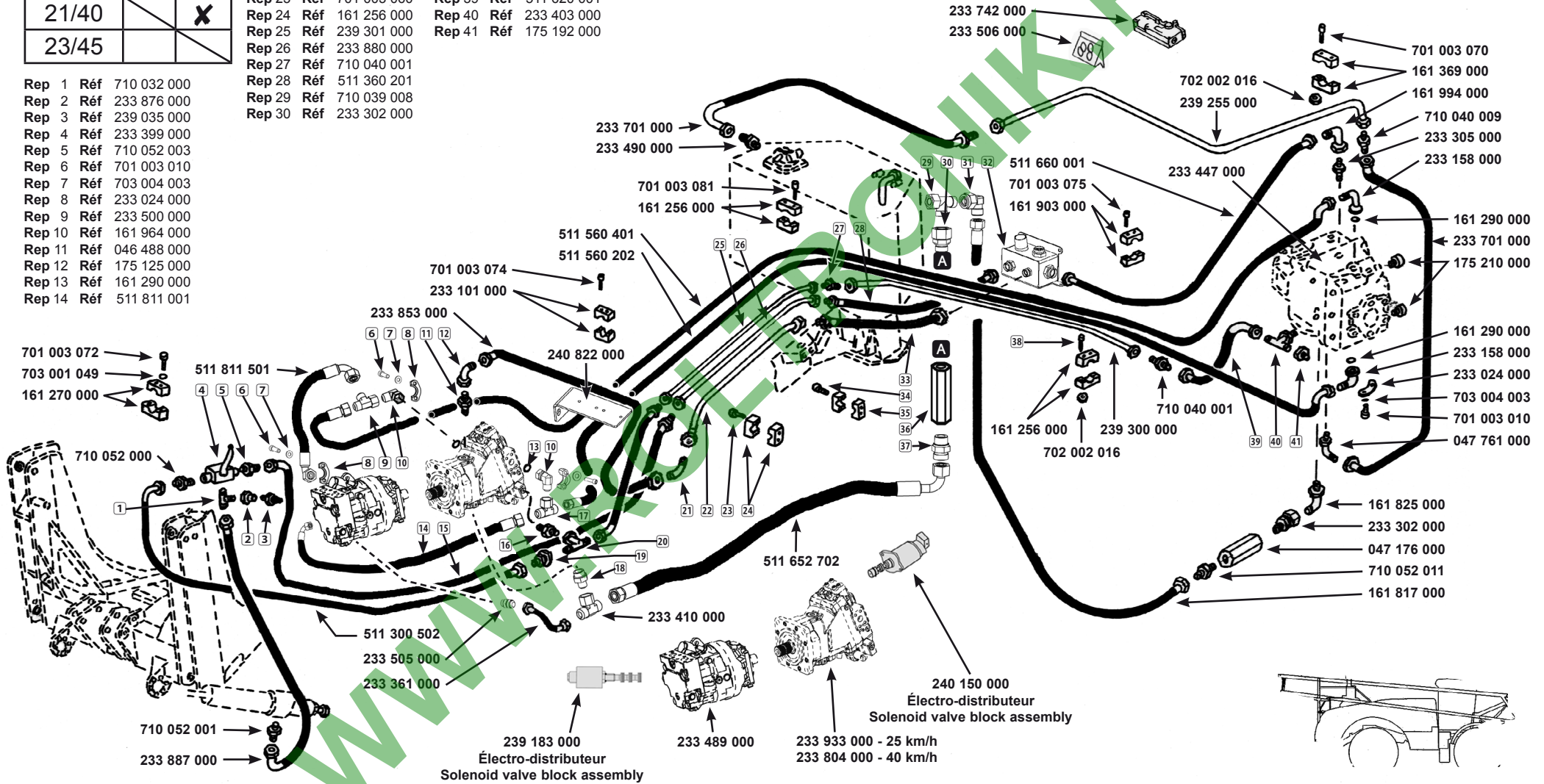

CATALOGUE MAESTRIA
RAMPE AV 2004
Ajout mars 2009/March 2009 Add

CIRCUIT HYDROSTATIQUE SAUER 2 MOTEURS
SAUER PUMP HYDRAULIC CIRCUIT WITH 2
ENGINES



4
B02
04/12/08

Km/h	25	40
17/39	X	X
17/40		X
21/39	X	X
21/40		X
23/45		

- Rep 1 Ref 710 032 000
- Rep 2 Ref 233 876 000
- Rep 3 Ref 233 399 000
- Rep 4 Ref 239 035 000
- Rep 5 Ref 703 004 009
- Rep 6 Ref 233 013 000
- Rep 7 Ref 161 630 000

- Rep 8 Ref 710 015 005
- Rep 9 Ref 710 040 001
- Rep 10 Ref 710 006 011
- Rep 11 Ref 233 880 000
- Rep 12 Ref 239 286 000
- Rep 13 Ref 511 350 301
- Rep 14 Ref 701 003 068
- Rep 15 Ref 233 657 000

- Rep 16 Ref 239 325 000
- Rep 17 Ref 161 352 000
- Rep 18 Ref 233 024 000
- Rep 19 Ref 710 000 017
- Rep 20 Ref 161 290 000
- Rep 21 Ref 701 003 010
- Rep 22 Ref 233 101 000

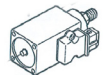

Solénoïde 12V sur moteur Linde Ref 239 660 000

**Chapitre 4
Planche A01**

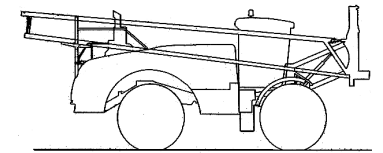
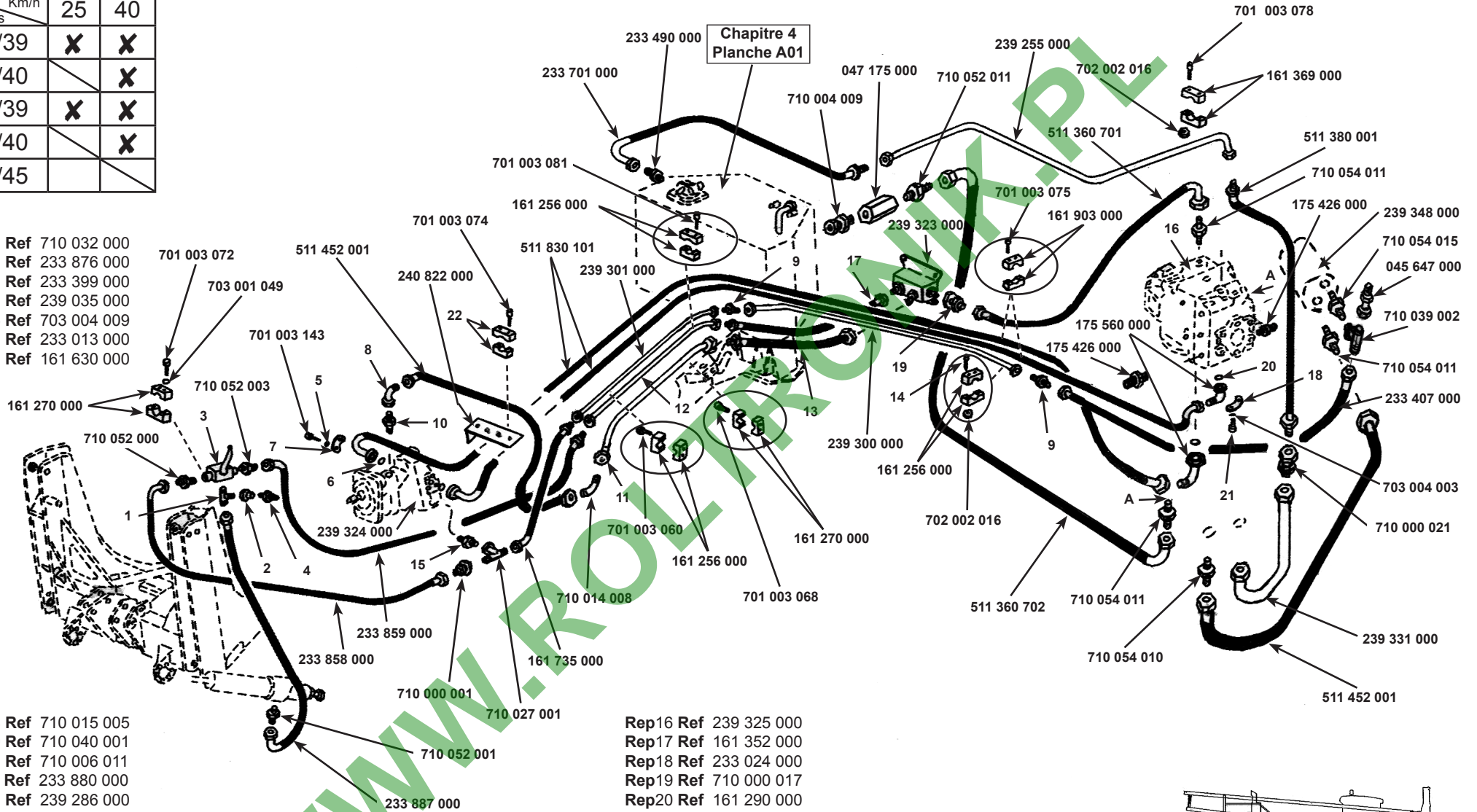

**CATALOGUE MAESTRIA
RAMPE AV 2004**

Correctif mars 2009/March 2009 correction

CIRCUIT HP POMPE LINDE LINDE PUMP HP CIRCUIT		4
		B03 06/12/04

Modèles	Km/h	
	25	40
17/39		
17/40		
21/39		
21/40		
23/45	X	

Rep 1	Réf	710 032 000
Rep 2	Réf	233 399 000
Rep 3	Réf	233 876 000
Rep 4	Réf	239 035 000
Rep 5	Réf	161 290 000
Rep 6	Réf	701 003 011
Rep 7	Réf	703 040 001
Rep 8	Réf	233 024 000
Rep 9	Réf	233 505 000
Rep 10	Réf	233 361 000
Rep 11	Réf	046 488 000
Rep 12	Réf	175 125 000
Rep 13	Réf	233 158 000
Rep 14	Réf	161 640 000
Rep 15	Réf	239 014 000

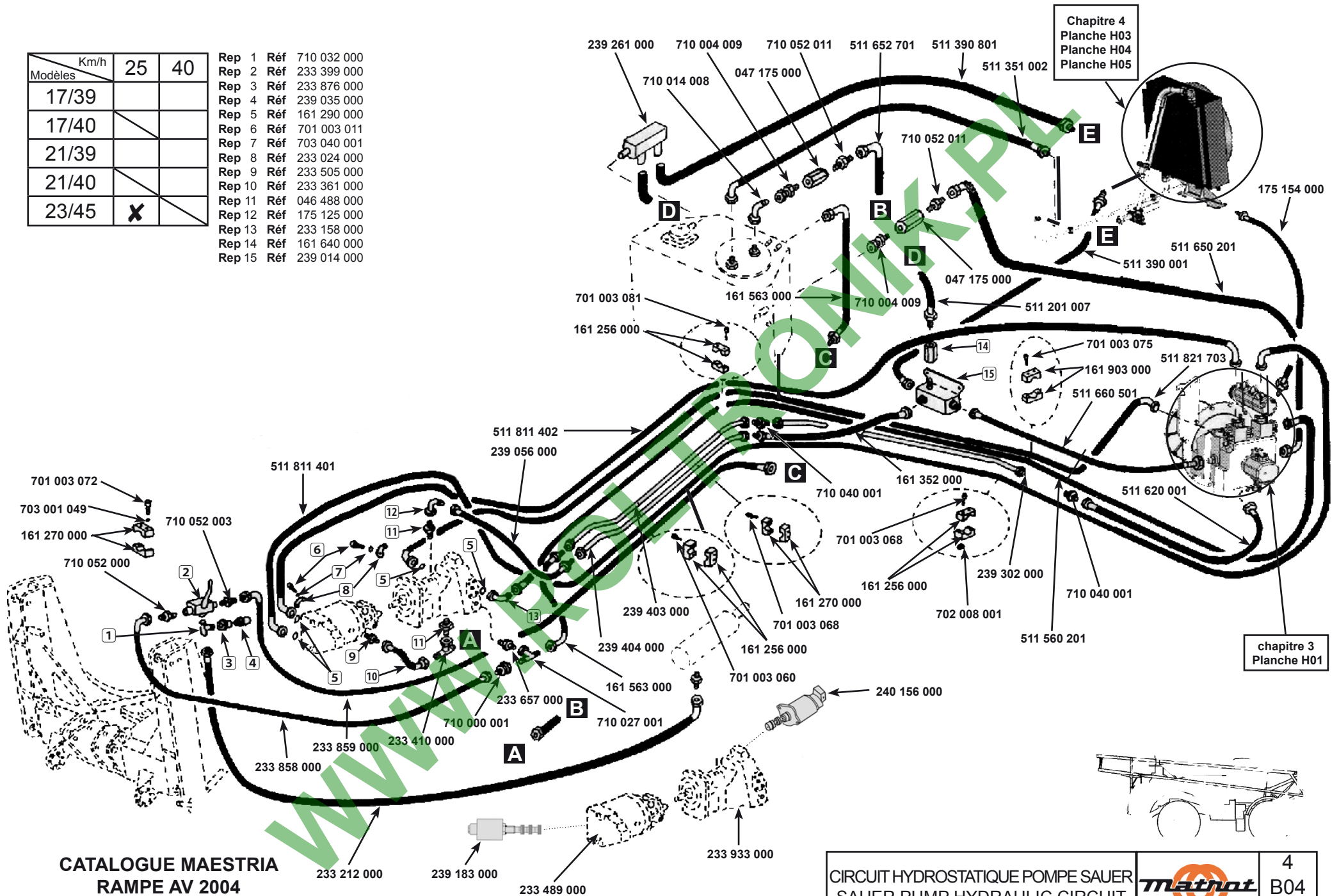

**CATALOGUE MAESTRIA
RAMPE AV 2004**

Correctif mars 2009/March 2009 correction

CIRCUIT HYDROSTATIQUE POMPE SAUER
SAUER PUMP HYDRAULIC CIRCUIT



4
B04
05/07/05

Km/h	25	40
17/39	X	X
21/39	X	X
23/45		

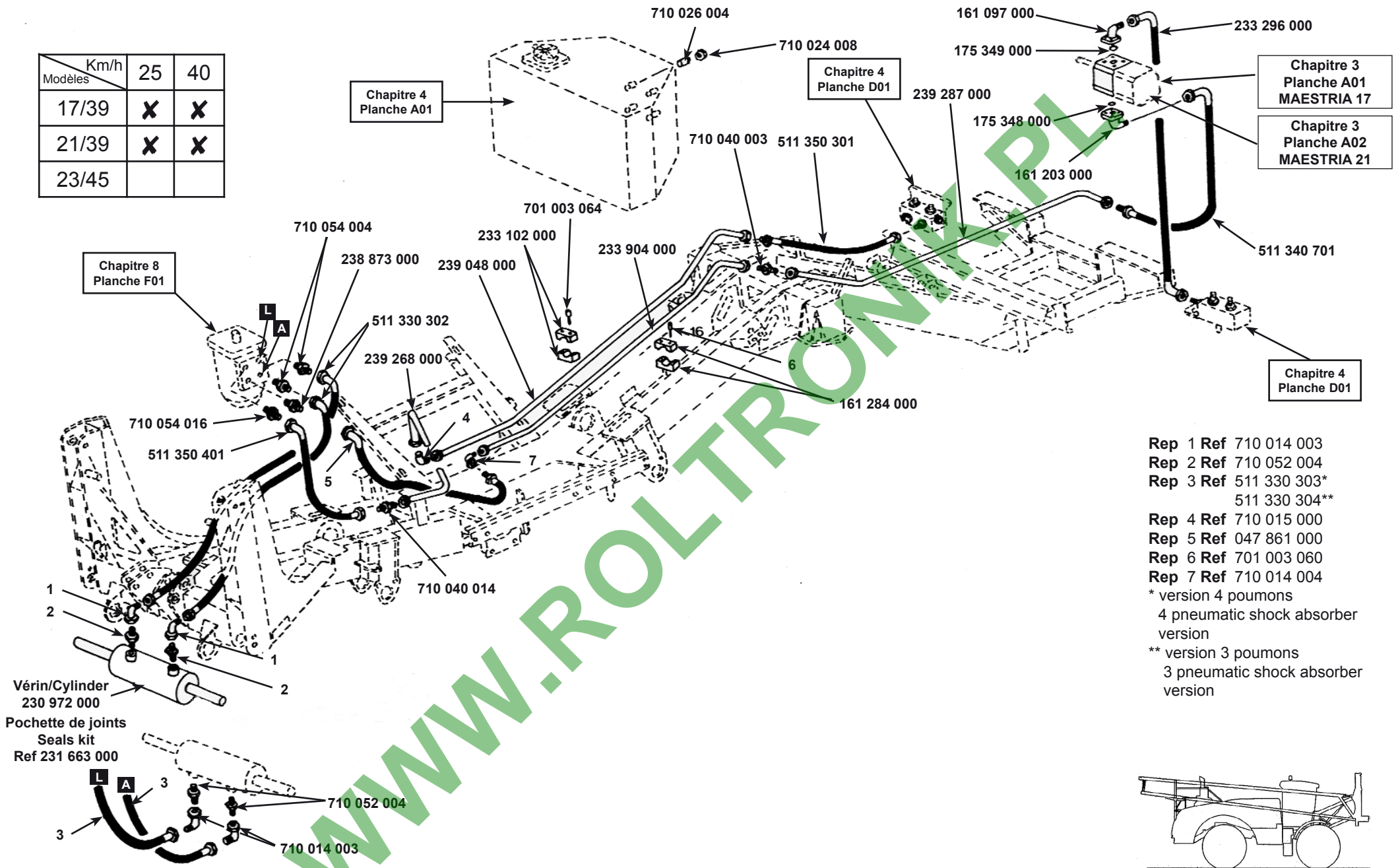

- Rep 1 Ref 710 014 003
- Rep 2 Ref 710 052 004
- Rep 3 Ref 511 330 303*
- 511 330 304**
- Rep 4 Ref 710 015 000
- Rep 5 Ref 047 861 000
- Rep 6 Ref 701 003 060
- Rep 7 Ref 710 014 004
- * version 4 poumons
4 pneumatic shock absorber version
- ** version 3 poumons
3 pneumatic shock absorber version

Vérin/Cylinder
230 972 000

Pochette de joints
Seals kit
Ref 231 663 000

**CATALOGUE MAESTRIA
RAMPE AV 2004**

Correctif mars 2009/March 2009 correction

CIRCUIT DIRECTION AV
FRONT STEERING CIRCUIT



4
C01
18/11/04

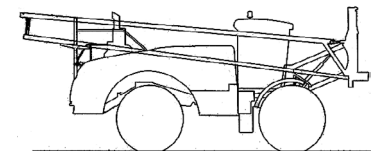

Km/h	25	40
17/39		
21/39		
23/45	X	

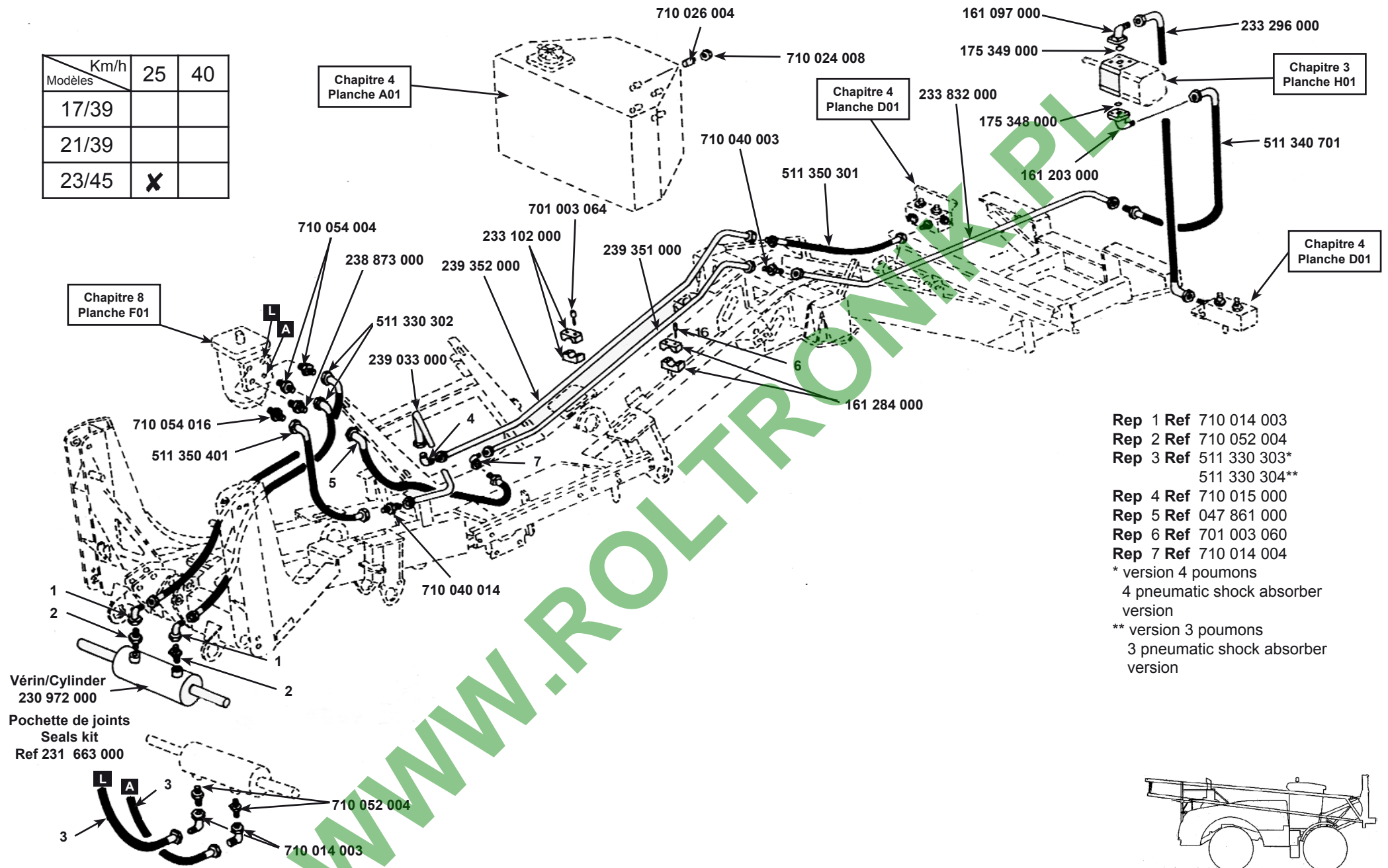

**CATALOGUE MAESTRIA
RAMPE AV 2004**

Correctif mars 2009/March 2009 correction

CIRCUIT DIRECTION AV
FRONT STEERING CIRCUIT



4
C02
18/11/04

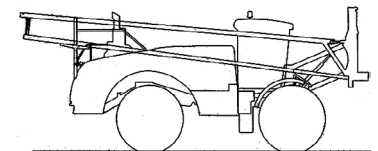

Modèles \ Km/h	25	40
17/39	X	X
17/40		X
21/39	X	X
21/40		X
23/45		

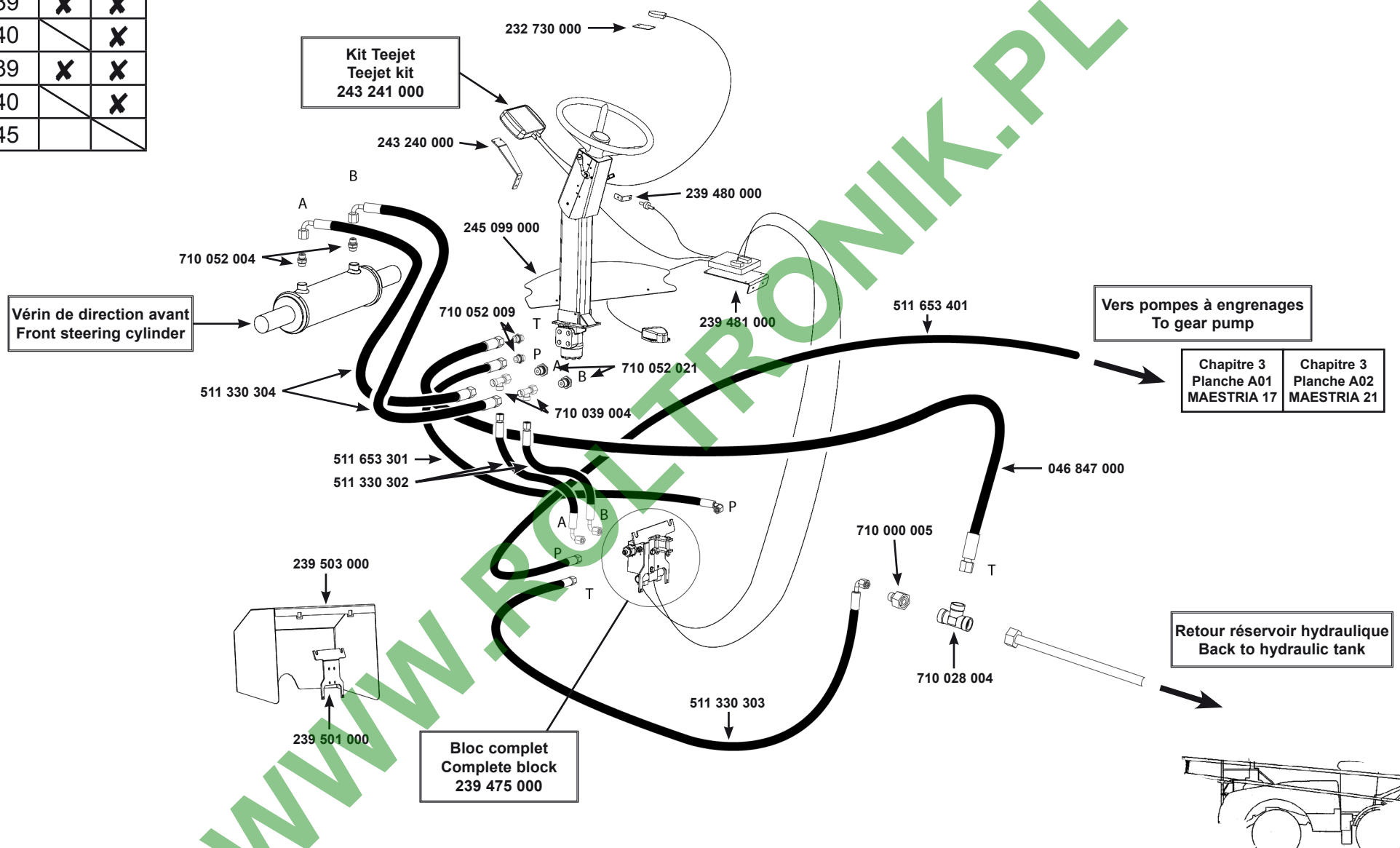

CATALOGUE MAESTRIA
RAMPE AV 2004
 Ajout mars 2009/March 2009 Add

OPTION AUTOGUIDAGE
 SELF-GUIDANCE OPTION



4
C03
 17/12/08

Km/h	25	40
17/39	X	X
21/39	X	X
23/45	X	X*

* Uniquement pour la version garde au sol 1 m.
Only for 1 metre ground clearance version.

Chapitre 4
Planche A01

- Rep 1 Ref 233 019 000
- Rep 2 Ref 710 006 002
- Rep 3 Ref 710 054 001
- Rep 4 Ref 701 003 060
- Rep 5 Ref 161 256 000
- Rep 6 Ref 161 594 000

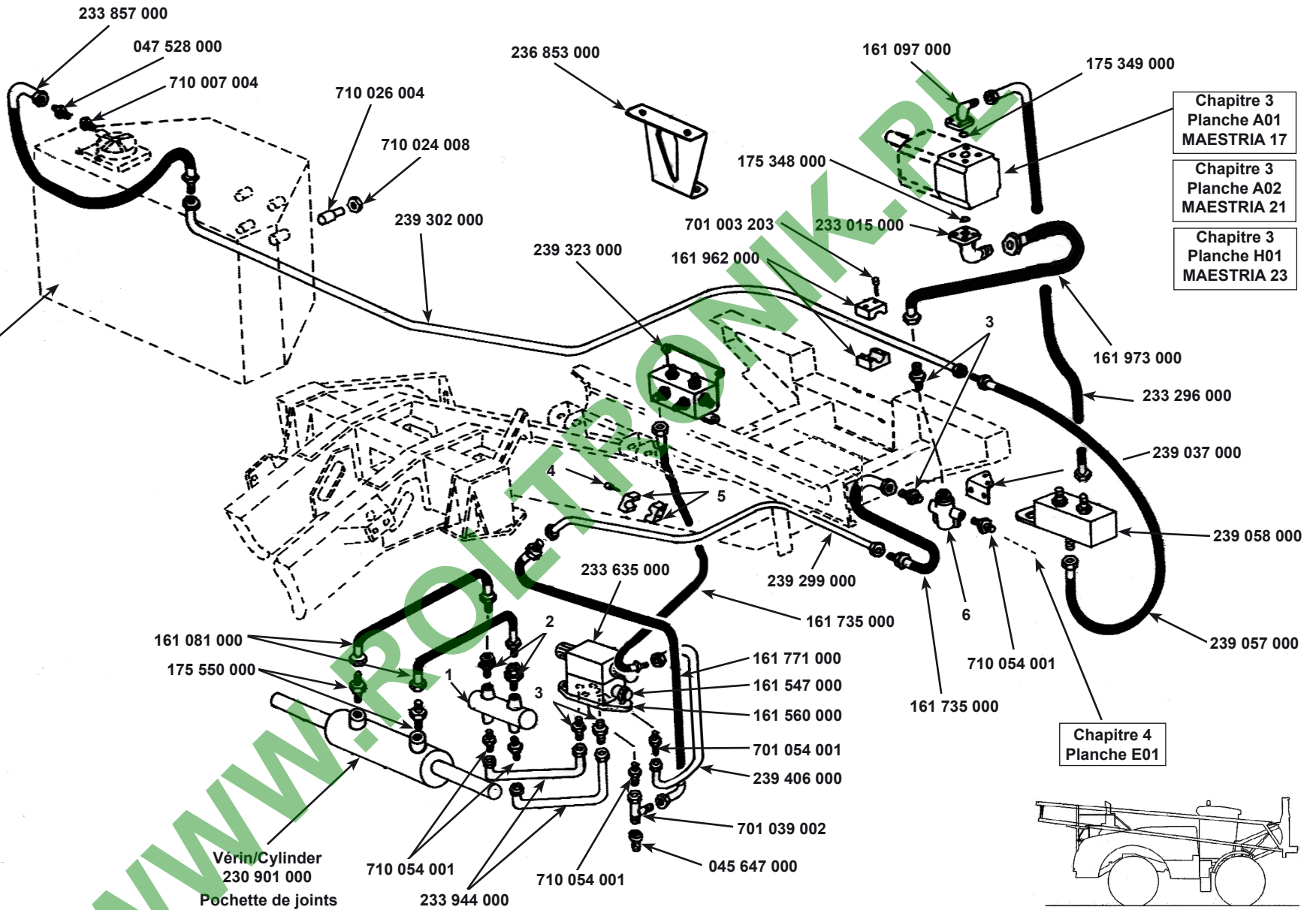

Chapitre 3
Planche A01
MAESTRIA 17

Chapitre 3
Planche A02
MAESTRIA 21

Chapitre 3
Planche H01
MAESTRIA 23

Chapitre 4
Planche E01

Vérin/Cylinder
230 901 000
Pochette de joints
Seals kit
Ref 231 663 000

**CATALOGUE MAESTRIA
RAMPE AV 2004**

Correctif mars 2006/March '06 correction

CIRCUIT DIRECTION AR
REAR STEERING CIRCUIT



4
D01
18/11/04

Km/h	25	40
17/39	X	X
21/39	X	X
23/45		

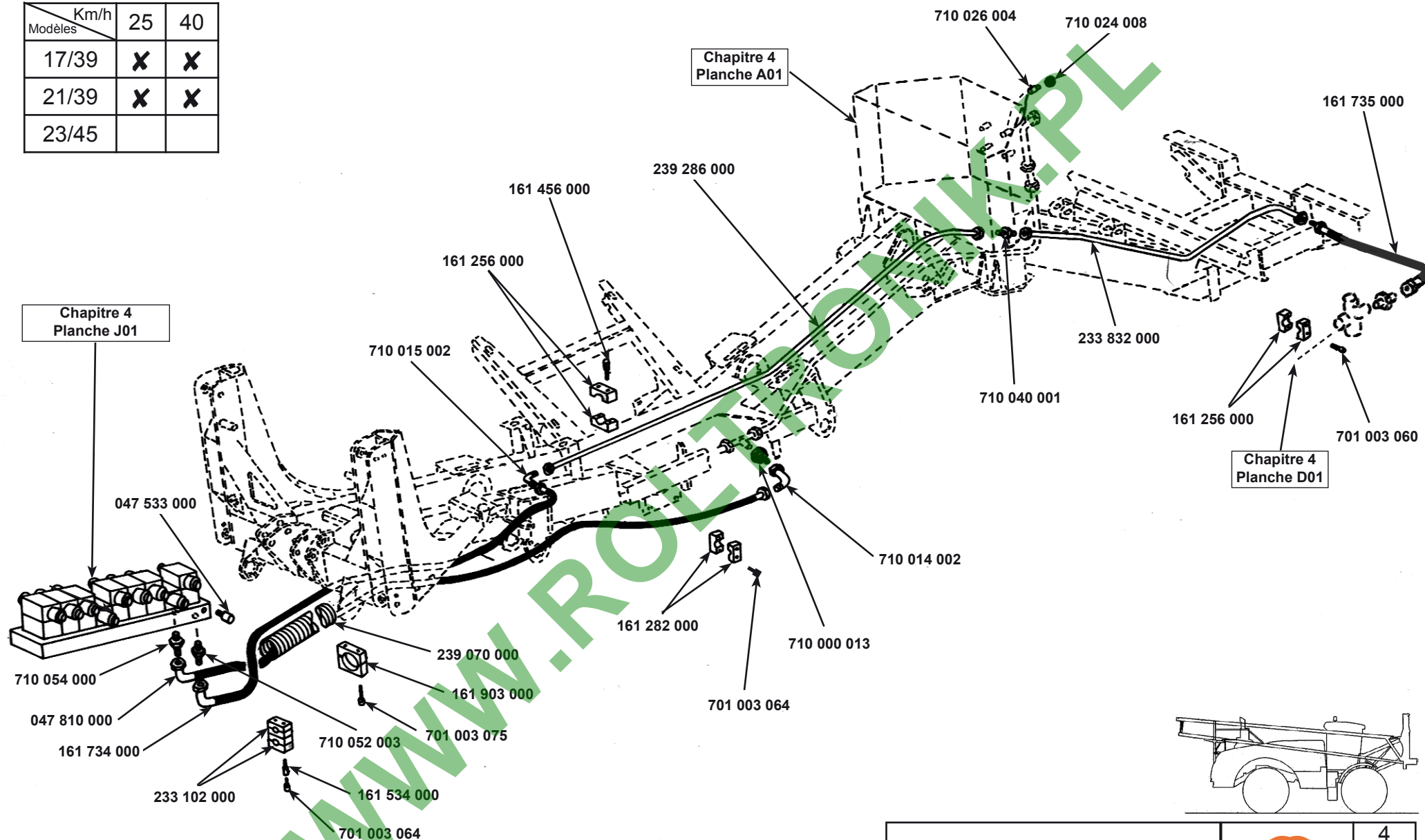

CATALOGUE MAESTRIA
RAMPE AV 2004

CIRCUIT BLOC ÉLECTROVANNE RAMPE
ELECTRIC CONTROL VALVES BOOM



4
E01
18/11/04

Km/h	25	40
17/39		
21/39		
23/45	X	X*

* Uniquement pour la version garde au sol 1 m.

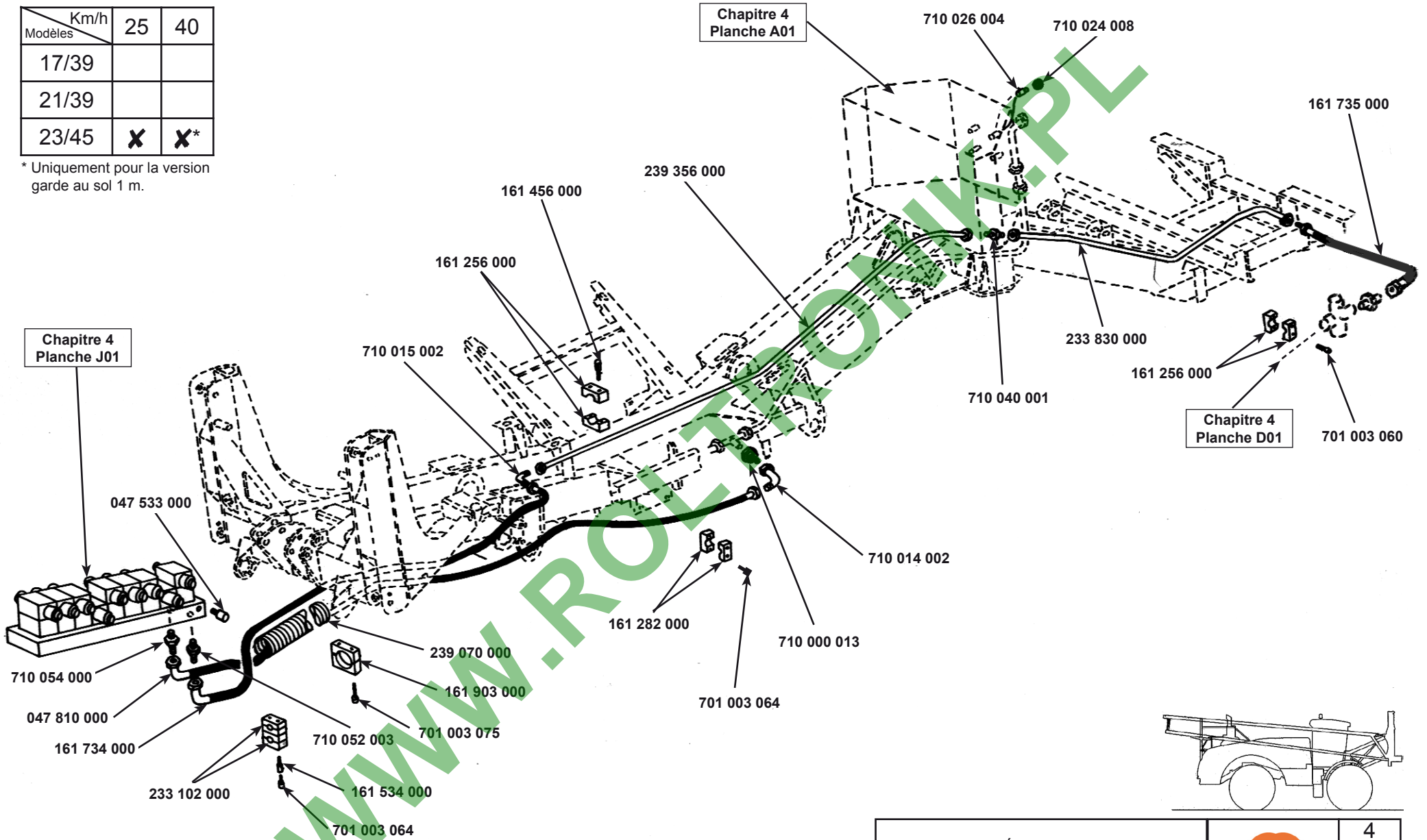

CATALOGUE MAESTRIA
RAMPE AV 2004

CIRCUIT BLOC ÉLECTROVANNE RAMPE
ELECTRIC CONTROL VALVES BOOM



4
E02
18/11/04

Km/h	25	40
17/39	X	X
21/39	X	X
23/45	X	

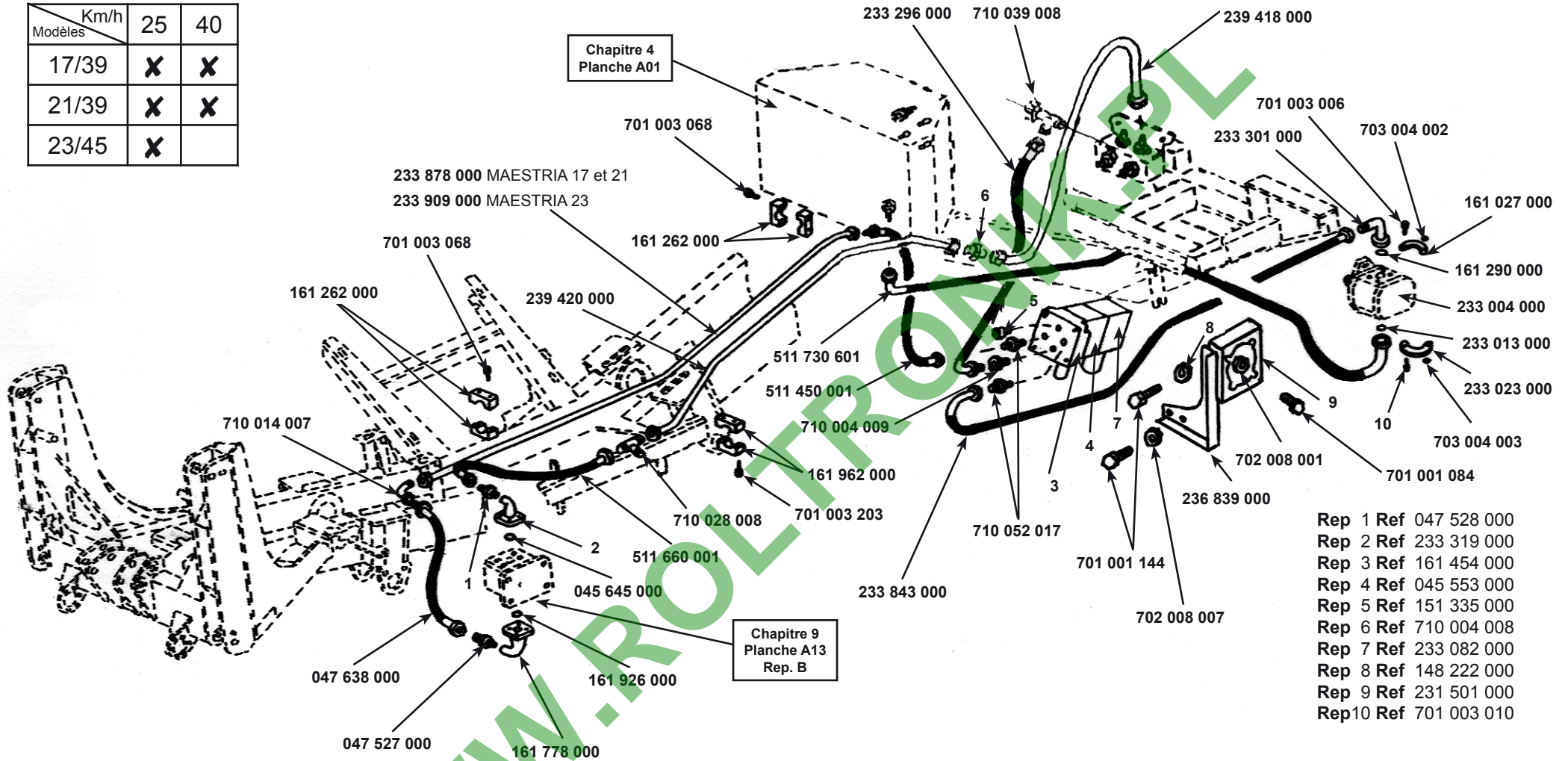

- Rep 1 Ref 047 528 000
- Rep 2 Ref 233 319 000
- Rep 3 Ref 161 454 000
- Rep 4 Ref 045 553 000
- Rep 5 Ref 151 335 000
- Rep 6 Ref 710 004 008
- Rep 7 Ref 233 082 000
- Rep 8 Ref 148 222 000
- Rep 9 Ref 231 501 000
- Rep10 Ref 701 003 010

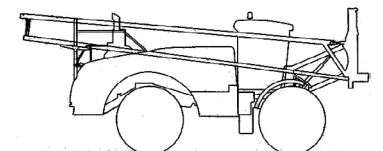

**CATALOGUE MAESTRIA
RAMPE AV 2004**

Correctif mars 2006/March '06 correction

CIRCUIT POMPE DE PULVÉRISATION SPRAYING PUMP CIRCUIT		4
		F01 18/11/04

Modèles \ Km/h	25	40
17/39		
17/40		
21/39		
21/40		
23/45		

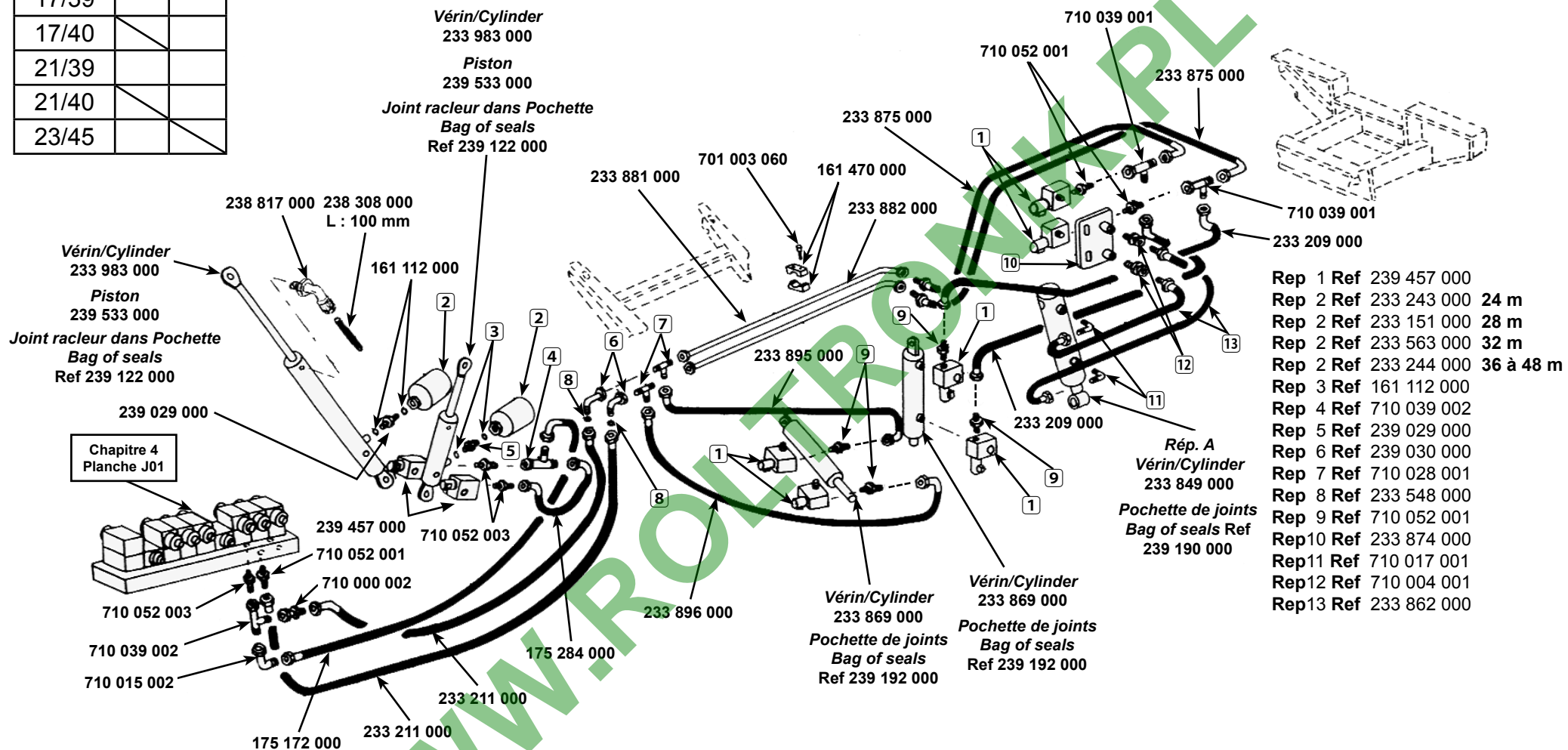

- Rep 1 Ref 239 457 000
- Rep 2 Ref 233 243 000 **24 m**
- Rep 2 Ref 233 151 000 **28 m**
- Rep 2 Ref 233 563 000 **32 m**
- Rep 2 Ref 233 244 000 **36 à 48 m**
- Rep 3 Ref 161 112 000
- Rep 4 Ref 710 039 002
- Rep 5 Ref 239 029 000
- Rep 6 Ref 239 030 000
- Rep 7 Ref 710 028 001
- Rep 8 Ref 233 548 000
- Rep 9 Ref 710 052 001
- Rep10 Ref 233 874 000
- Rep11 Ref 710 017 001
- Rep12 Ref 710 004 001
- Rep13 Ref 233 862 000

CATALOGUE MAESTRIA
RAMPE AV 2004

Correctif février 2010/February 2010 correction

Modèles \ Km/h	25	40
17/39		
17/40		
21/39		
21/40		
23/45		

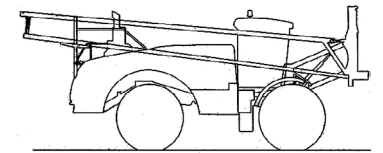
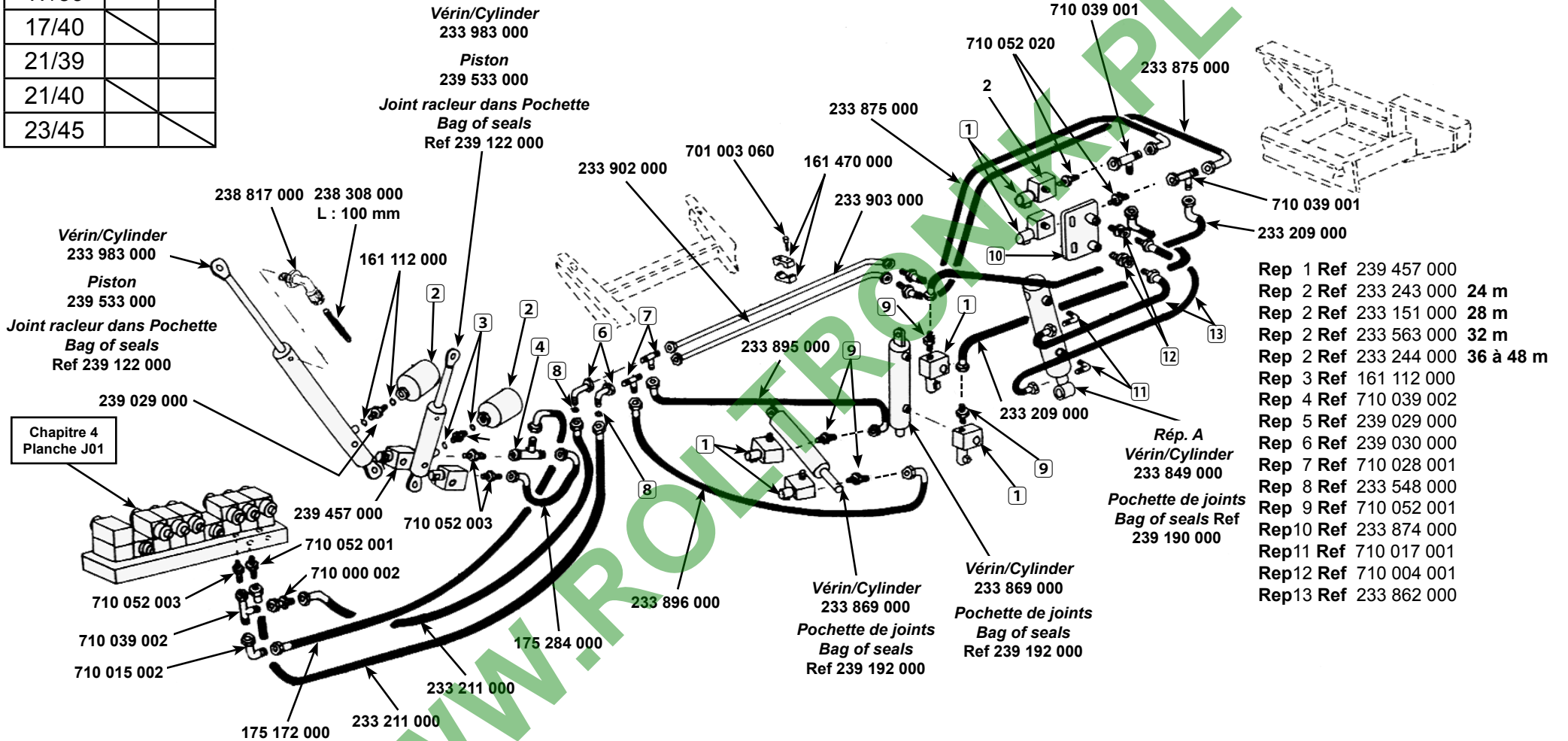

CATALOGUE MAESTRIA
RAMPE AV 2004

Correctif février 2010/February 2010 correction

CIRCUIT ÉCHELLE INCORPORATEUR
INCORPORATOR AND LADDER CIRCUIT



4
G02
19/12/04

Modèles \ Km/h	25	40
17/39		
17/40		
21/39	X	X
21/40		X
23/45		

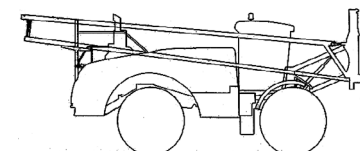
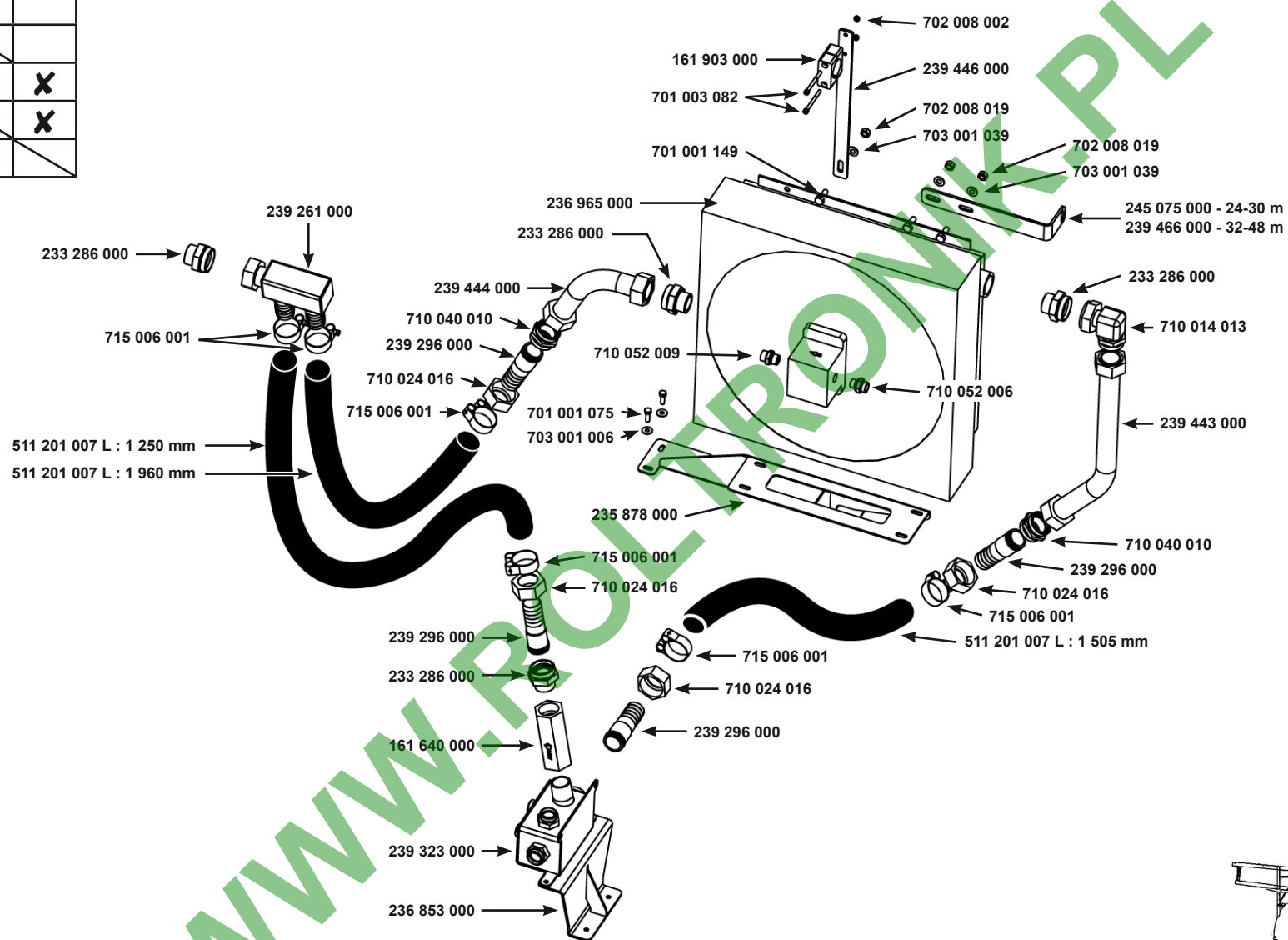

**CATALOGUE MAESTRIA
RAMPE AV 2004**

Correctif mars 2009/March 2009 correction

CIRCUIT REFROIDISSEUR
OIL COOLER CIRCUIT



4
H01
11/12/08

Km/h	25	40
17/39	X	X
21/39		
23/45		

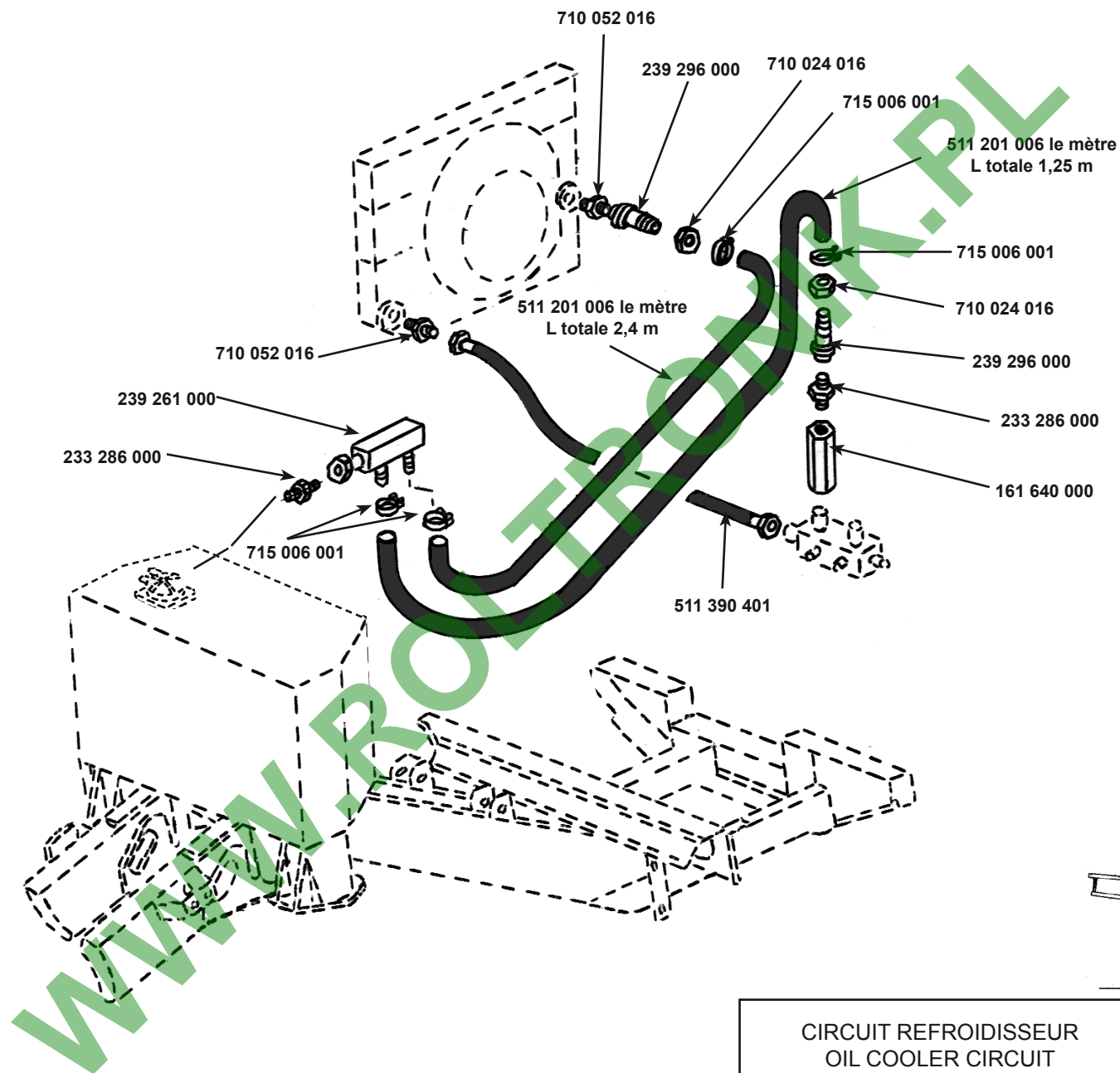

CATALOGUE MAESTRIA
RAMPE AV 2004

CIRCUIT REFROIDISSEUR
OIL COOLER CIRCUIT



4
H02
08/12/04

Km/h	25	40
17/39		
21/39		
23/45	X	X*

* Uniquement pour la version garde au sol 1 m.

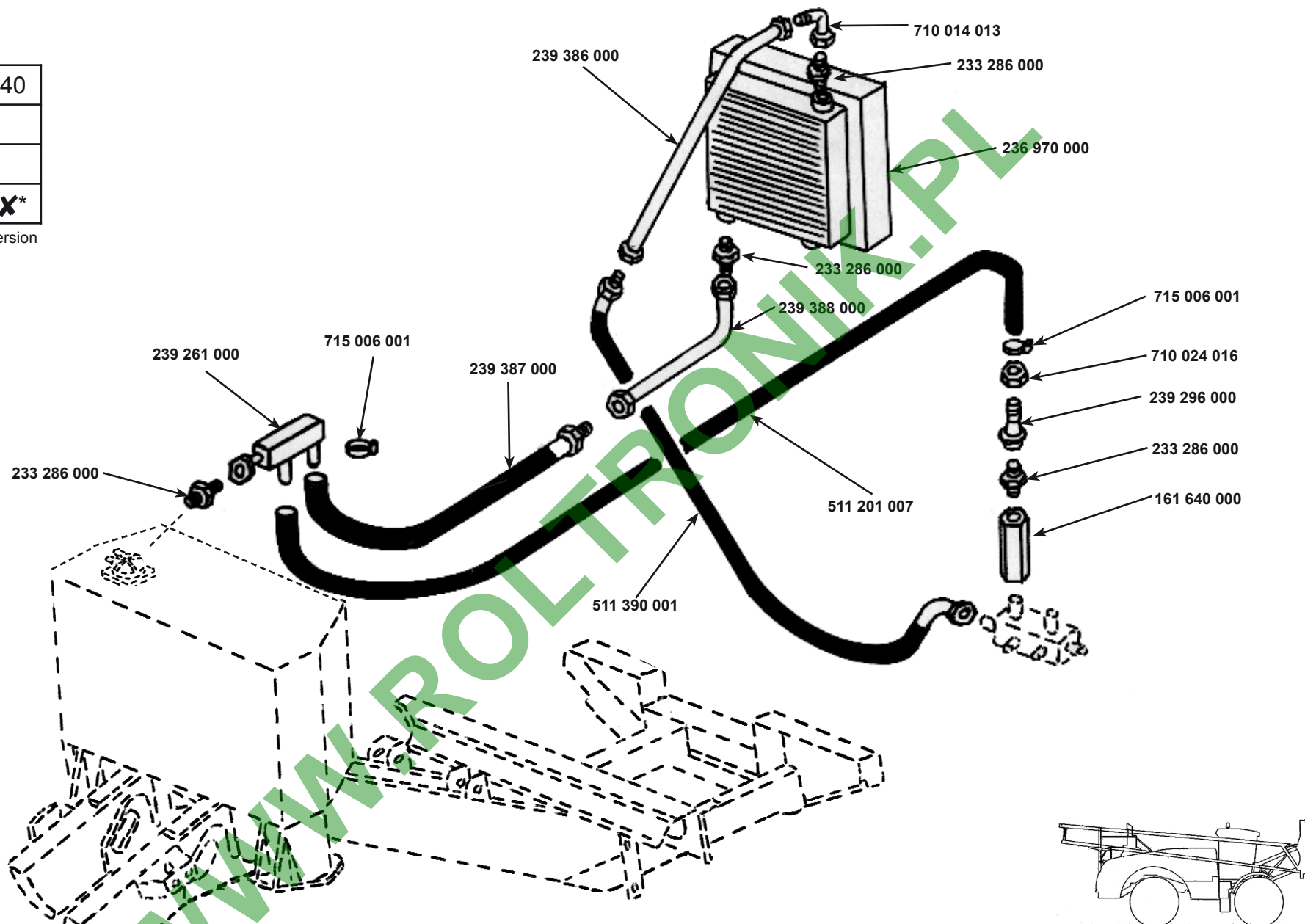

Km/h	25	40
17/39		
21/39		
23/45	X	

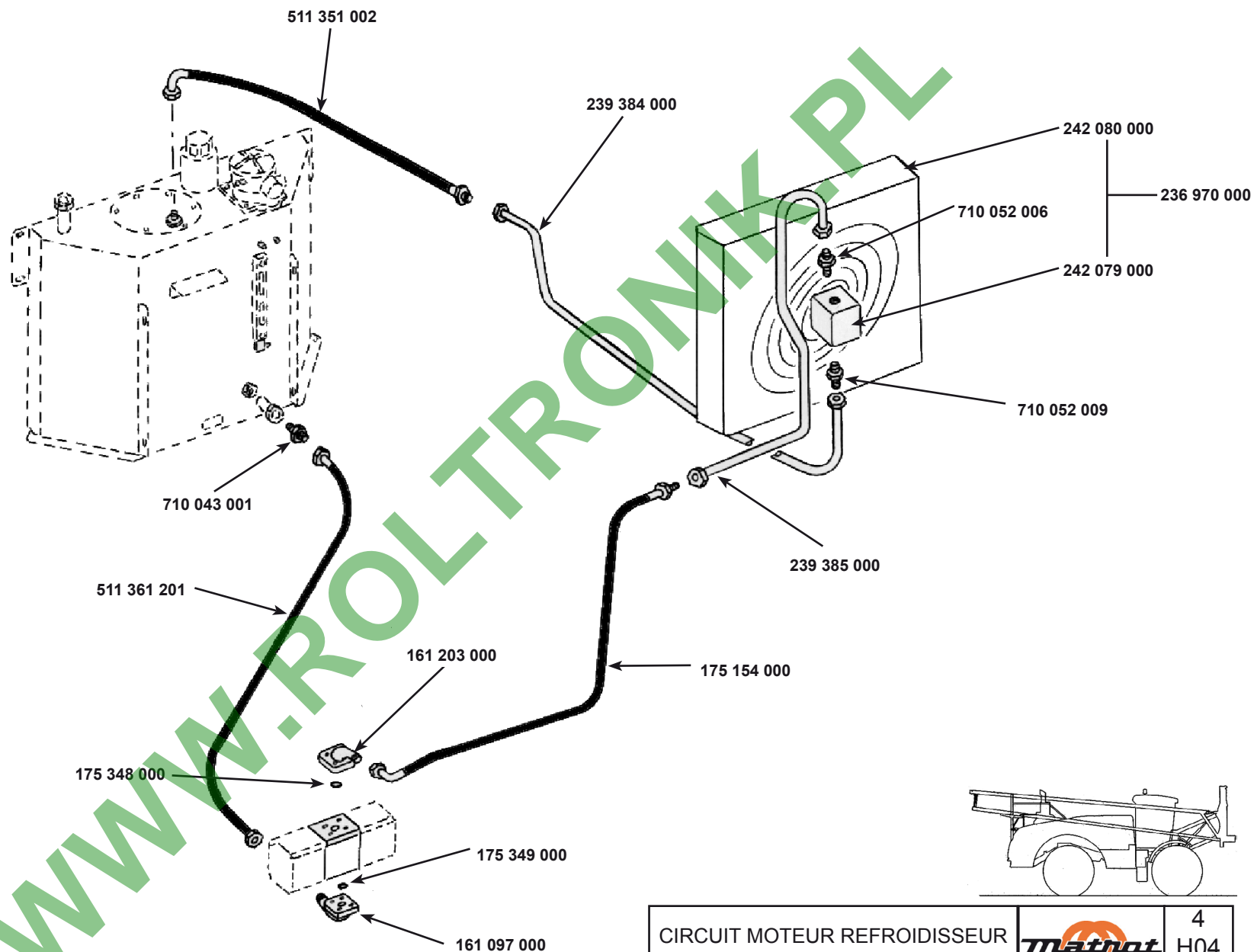

CATALOGUE MAESTRIA
RAMPE AV 2004

CIRCUIT MOTEUR REFROIDISSEUR
OIL COOLER MOTOR CIRCUIT



4
H04
16/05/05

Km/h	25	40
Modèles		
17/39		
21/39		
23/45	X	X*

* Uniquement pour la version garde au sol 1 m.

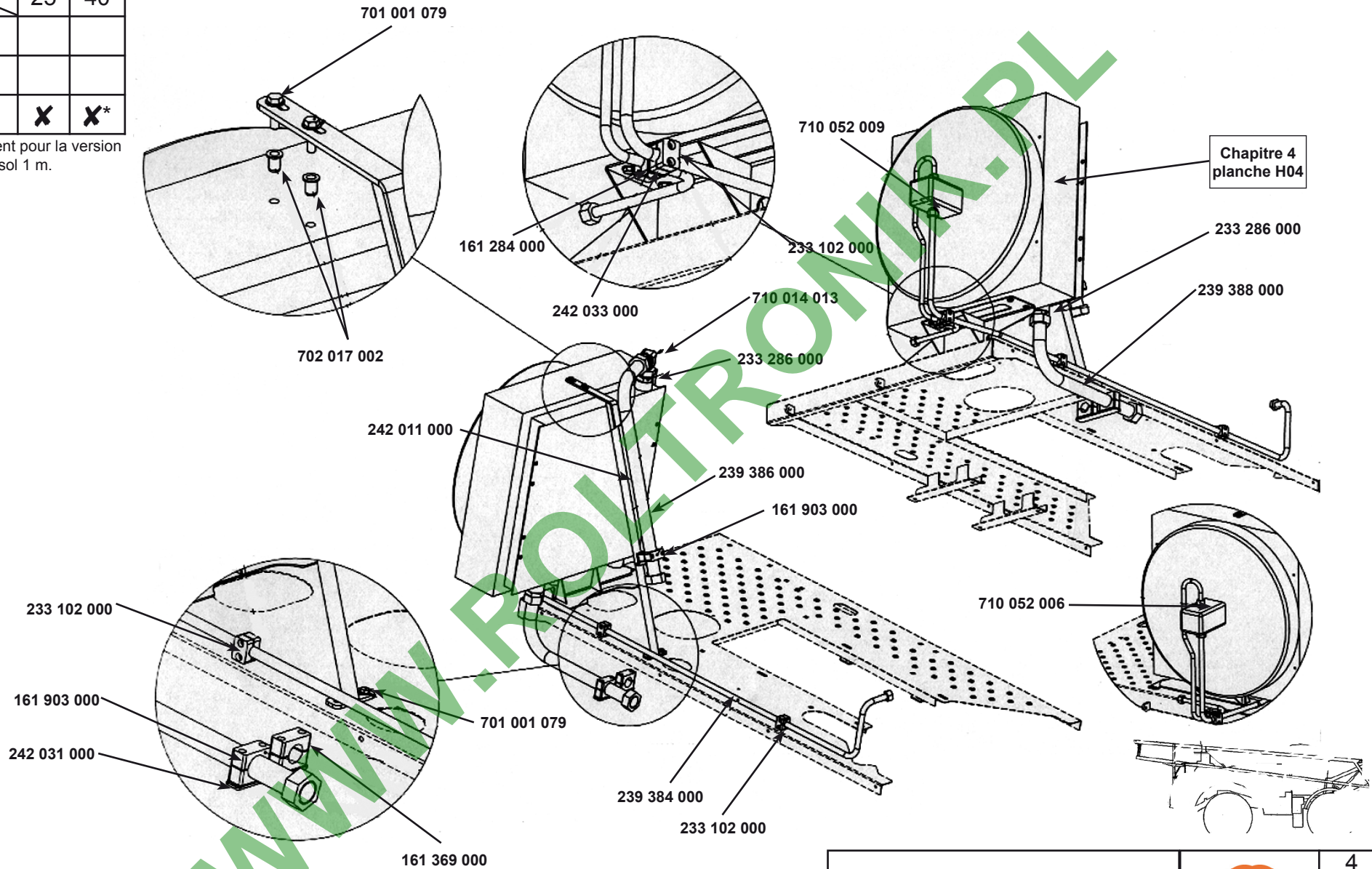

Km/h	25	40
17/39		
17/40		
21/39	X	X
21/40		
23/45		

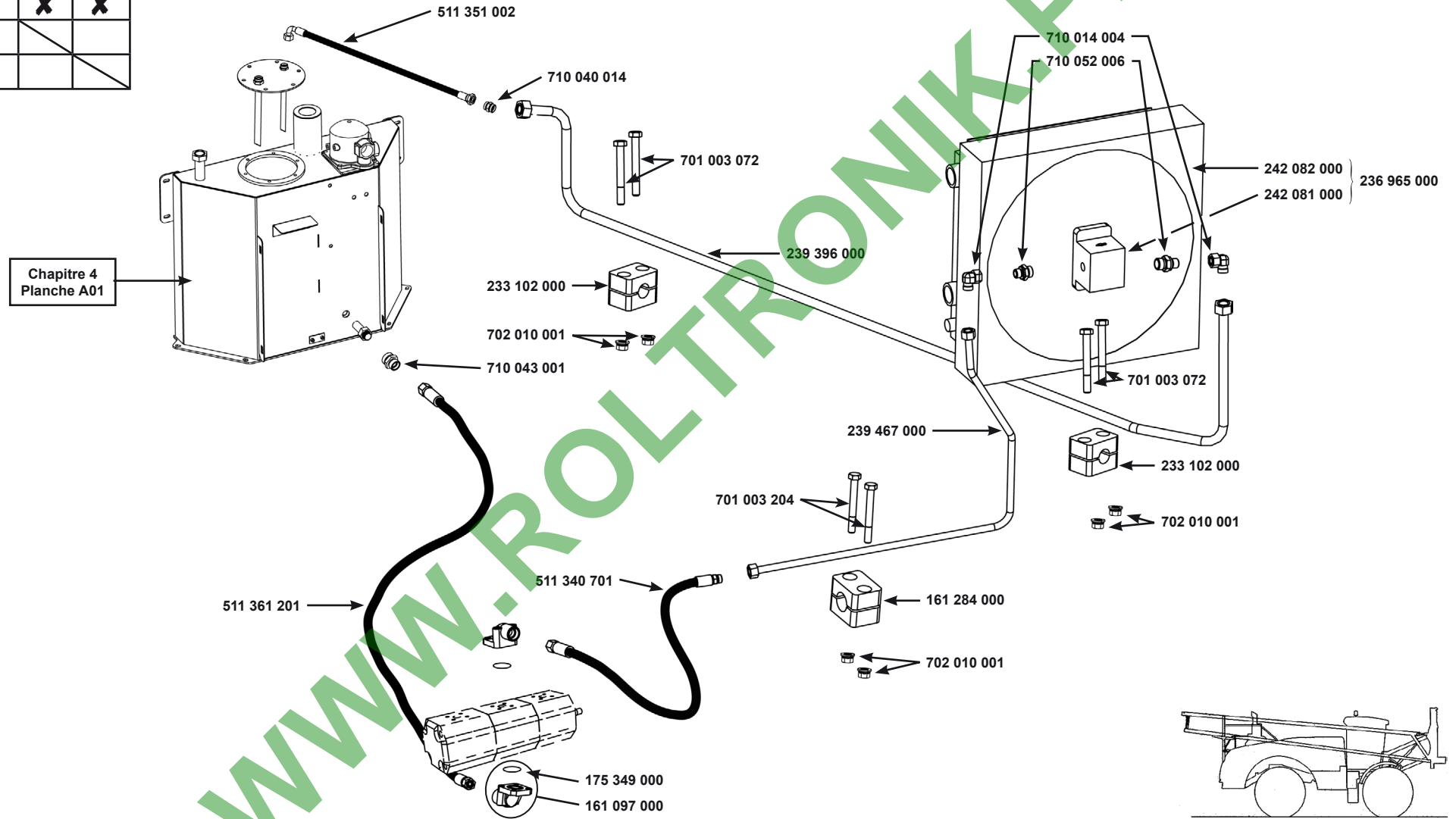

**CATALOGUE MAESTRIA
RAMPE AV 2004**

Correctif mars 2009/March 2009 correction

CIRCUIT MOTEUR REFROIDISSEUR
OIL COOLER CIRCUIT



4
H06
02/11/05

Km/h	25	40
17/39	X	X
17/40		X
21/39	X	X
21/40		X
23/45	X	

Rep	Ref	
1	233 474 000	24/32 m
1	233 472 000	36/49 m
2	239 007 000	24/32 m
2	233 606 000	36/49 m

Embout de vérin/Cylinder's tip	
239 492 000	24 à 30 m 25 km/h
239 426 000	26 à 30 m 40 km/h + Stabilis®
233 337 000	32 à 48 m 25 km/h
239 410 000	32 à 48 m 40 km/h

233 254 000	24 à 30 m
233 259 000	32 à 38 m
233 663 000	40 à 42 m
239 197 000	44 à 49 m

233 352 000	24 à 30 m
233 357 000	32 à 38 m
239 199 000	40 à 42 m
239 202 000	44 à 49 m

233 358 000	24 à 30 m
233 352 000	32 à 38 m
239 200 000	40 à 42 m
239 202 000	44 à 49 m

233 257 000	24 à 30 m
233 318 000	32 à 38 m
233 799 000	40 à 42 m
239 196 000	44 à 49 m

233 546 000	jusqu'à/until 38 m
233 745 000	à partir de/from 40 m

233 548 000	jusqu'à/until 38 m
233 746 000	à partir de/from 40 m

233 245 000	24 et 36 m
233 152 000	28/38/40/42 m
233 154 000	32 m
239 012 000	44/48 m

233 347 000	24 à 30 m
233 349 000	32 à 38 m
239 519 000	40 m
233 521 000	42 m
233 522 000	44 m
233 524 000	48 m
511 310 101	50 m

233 346 000	24 à 30 m
233 348 000	32 à 38 m
239 349 000	40 m
233 519 000	42 m
233 521 000	44 m
233 523 000	48 m
233 524 000	50 m

Kit réparation* Réf 233 723 000
 du Vérin 233 472 000 36 à 49 m
 et du Vérin 233 737 000 36 à 49 m
 * Repair kit

233 474 000	24 à 32 m
233 737 000	36 à 49 m

233 650 000	24 à 30 m
233 873 000	32 à 38 m
239 201 000	40 à 42 m
239 194 000	44 à 49 m

233 568 000	24 à 30 m
233 570 000	32 à 38 m
233 844 000	40 à 42 m
233 942 000	44 à 49 m

Vérin/Cylinder
233 569 000

Pochette de joints
Seals kit
239 193 000

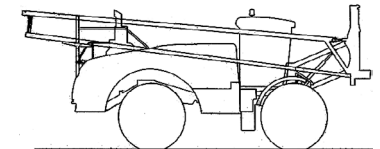

Chapitre 4
Planche J01

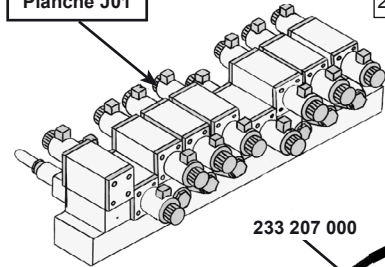

233 568 000	24 à 30 m
233 570 000	32 à 38 m
233 844 000	40 à 42 m
233 942 000	44 à 49 m

233 650 000	24 à 30 m
233 873 000	32 à 38 m
239 201 000	40 à 42 m
239 194 000	44 à 49 m

K	
233 254 000	24 à 30 m
233 259 000	32 à 38 m
239 195 000	40 à 42 m
239 198 000	44 à 49 m

Rep 3	Ref 710 004 003
Rep 4	Ref 710 028 002
Rep 5	Ref 710 006 001
Rep 6	Ref 161 517 000
Rep 7	Ref 710 048 001
Rep 8	Ref 710 004 001
Rep 9	Ref 710 017 001
Rep 10	Ref 233 306 000
Rep 11	Ref 047 295 000
Rep 12	Ref 233 210 000
Rep 13	Ref 710 028 001
Rep 14	Ref 233 545 000
Rep 15	Ref 233 548 000

233 207 000
233 211 000

233 211 000

233 885 000

710 052 001 qté 12

233 212 000

Stabilis®	
Qté/Qty : 2	
239 370 000	24 à 30 m
	32 à 36 m
	36 à 48 m

CIRCUIT ALIMENTATION RAMPE
BOOM HYDRAULIC CIRCUIT



4
101
18/11/04

CATALOGUE MAESTRIA
RAMPE AV 2004

Correctif mars 2009/March 2009 correction

Modèles \ Km/h	25	40
17/39	X	X
17/40		X
21/39	X	X
21/40		X
23/45		

091 137 000 **A**
 Filtre/Filter 091 141 000

Rep 1	Réf	239 457 000
Rep 2	Réf	710 056 002
Rep 3	Réf	710 052 004
Rep 4	Réf	045 502 004
Rep 5	Réf	710 052 003
Rep 6	Réf	710 004 003
Rep 7	Réf	239 389 000
Rep 8	Réf	239 399 000
Rep 9	Réf	710 052 005
Rep 10	Réf	710 004 006
Rep 11	Réf	710 052 006

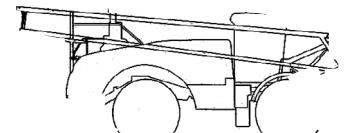
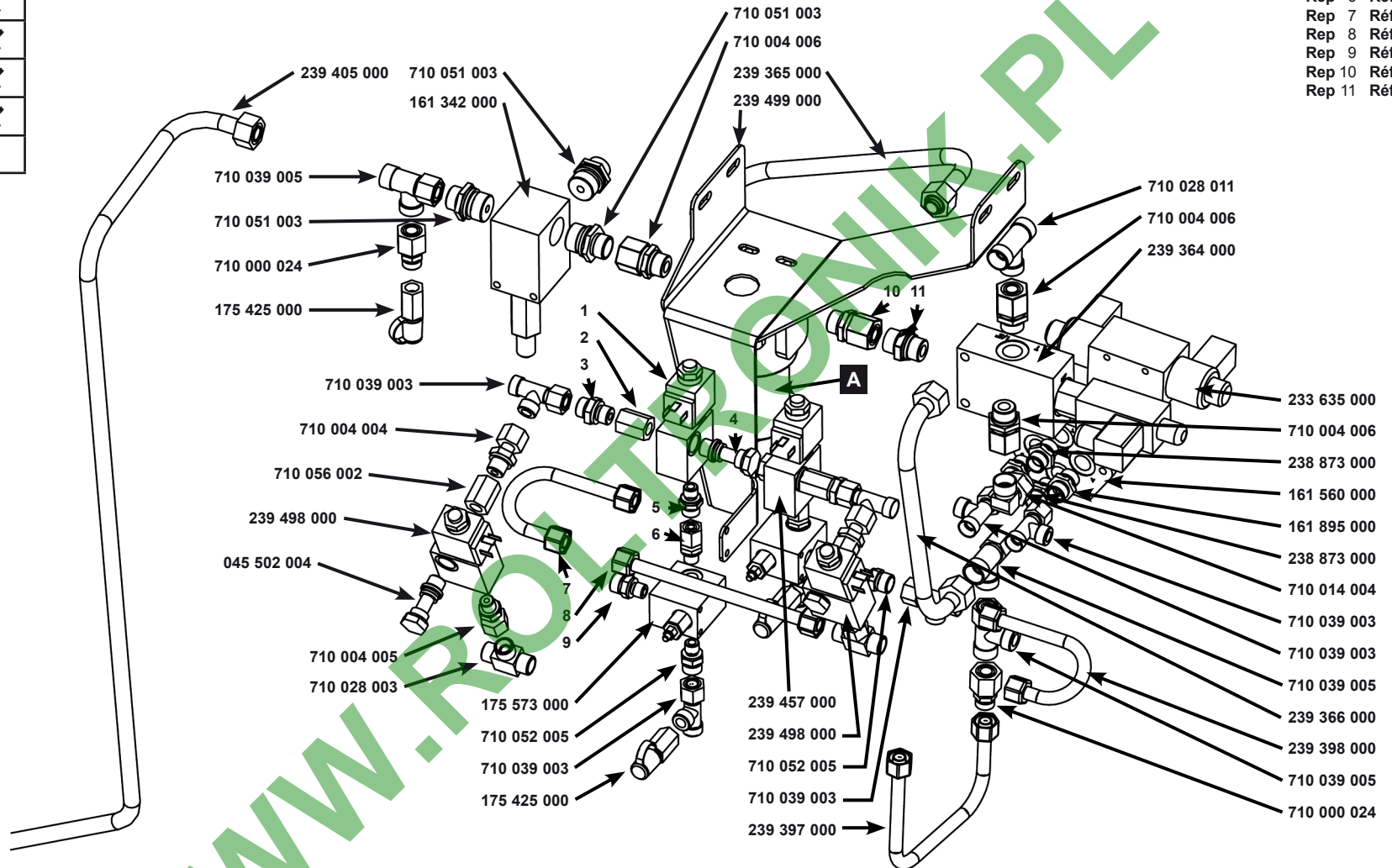

**CATALOGUE MAESTRIA
 RAMPE AV 2004**

Correctif mars 2009/March 2009 correction

BLOC DISTRIBUTION STABILIS®
 STABILIS® DISTRIBUTION BLOCK



4
K01
 03/11/08

Modèles \ Km/h	25	40
17/39		
17/40		X
21/39		
21/40		X
23/45		

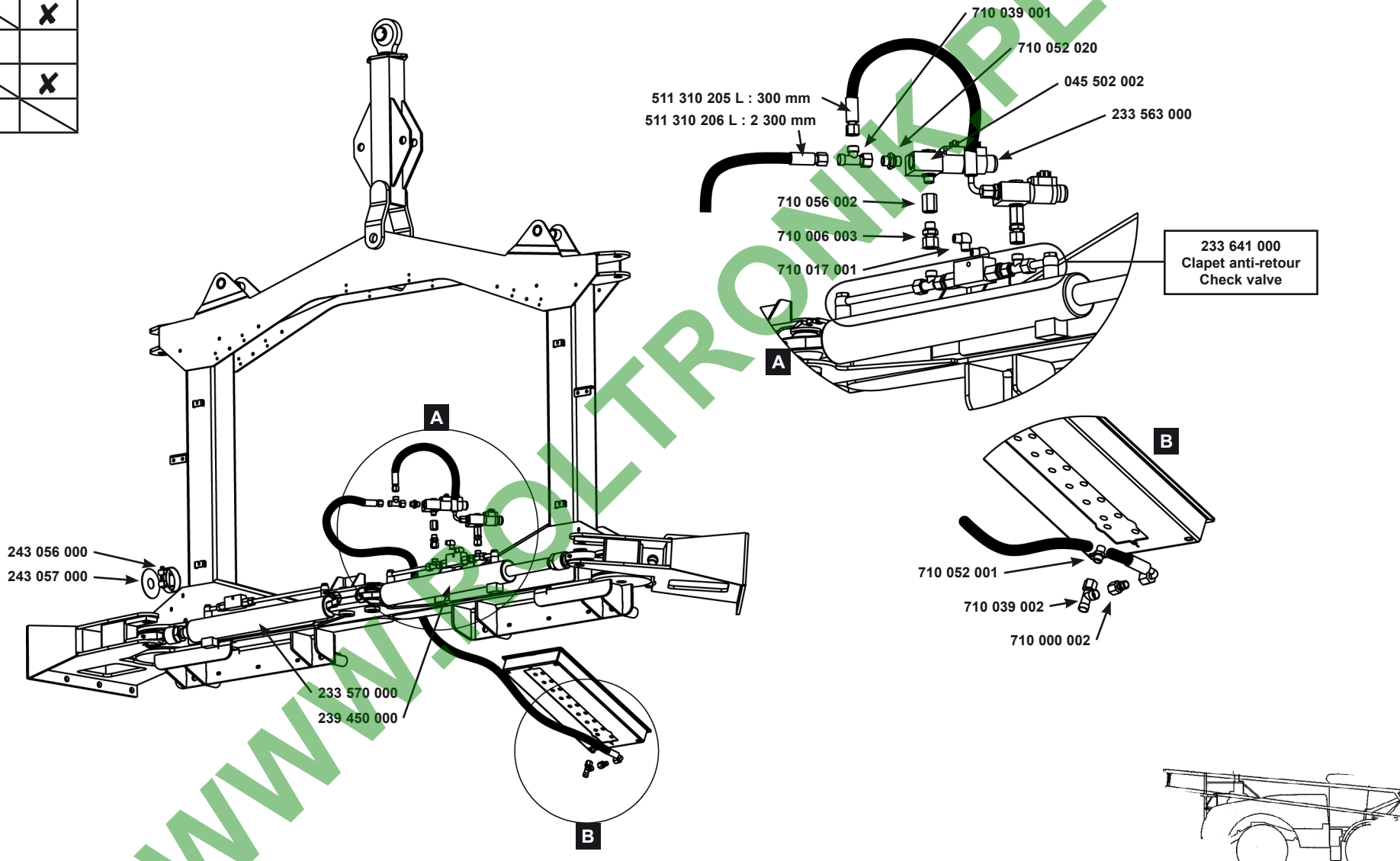

Km/h	25	40
17/39		
17/40		X
21/39		
21/40		X
23/45		

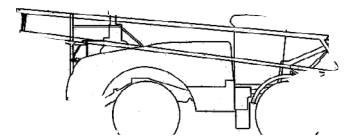
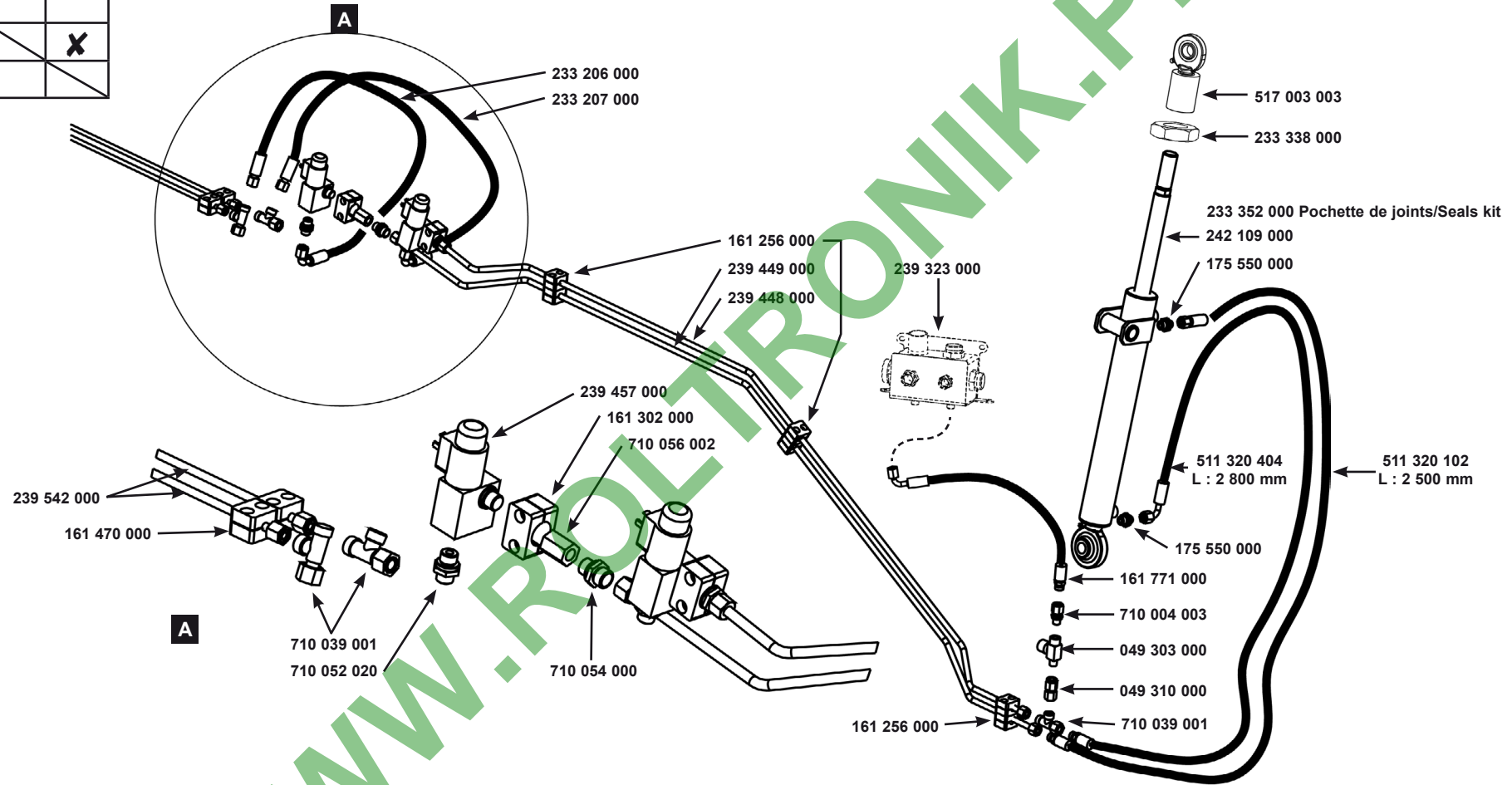

CATALOGUE MAESTRIA
RAMPE AV 2004
Ajout mars 2009/March 2009 Add

CIRCUIT REPLI PLATEAU RAMPE DROITE
RIGHT BOOM SHELF WITHDRAW CIRCUIT



4
L02
02/12/08