

Référence Item number	Indice Index	Désignation Designation	Qté/machine Qty/sprayer
162 054 000		Tresse de masse / Frame braid	1
162 469 000		Faisceau klaxon / Horn wiring harness	1
176 071 000		Pédale équipée / Equiped pedal	1
234 134 000	A	Tresse de masse / Frame braid	2
234 234 000	A	Faisceau vanne de régulation / Regulation valve wiring harness	1
234 481 000		Faisceau potentiomètre / Potentiometer wiring harness	1
234 767 000	J	Faisceau plancher / Floor pan wiring harness	1
234 786 000	D	Faisceau alimentation vannes 860 / 860's supply valve wiring harness	1
234 787 000	C	Faisceau poignée / Joystick wiring harness	1
234 788 000	C	Faisceau capteur 860 / 860's sensor wiring harness	1
750 001 060		Faisceau dans la cabine / Inner cab wiring harness	1
750 001 003		Câble coupe circuit - démarreur / Cut circuit-starter cable	1
750 001 004		Câble négatif pupitre au moteur / Negative cable from desk to engine	1
750 001 005		Câble batterie négatif / Negative battery cable	1
750 001 006		Câble batterie positif / Positive battery cable	1
750 001 007		Câble charge alternateur / Alternator charge cable	1
750 001 009		Câble coupe circuit - démarreur / Cut circuit-starter cable (Maestria 23.45)	1
750 001 010		Câble négatif pupitre au moteur / Negative cable from desk to engine (Maestria 23.45)	1
750 001 012		Câble du fusible de préchauffage au boîtier de préchauffage / Preheating fuse cable of preheating box	1
750 001 030		Faisceau microrupteur (nouveau modèle) / Microswitch wiring harness (new model)	2
750 001 031	A	Faisceau avant pour pont 1m30 / Front wiring harness for 1.30 m axle	1
750 001 058		Faisceau pupitre moteur euro 3 / Euro 3 engine desk wiring harness	1
750 001 057		Faisceau voyant / Warning light wiring harness	1
750 001 041	A	Faisceau moteur euro 3 / Euro 3 engine wiring harness	1
750 001 042		Câble du boîtier relais aux bougies de préchauffage / Relay box cable to glow plug	1
750 001 043		Câble de l'alternateur au fusible de préchauffage / Alternator cable to preheating fuse	1
750 001 044		Faisceau arrière rallongé moteur euro 3 / Euro 3 engine rear extended wiring harness (Maestria 23.45)	1
750 001 045		Faisceau éclairage arrière gauche et droite / Left and right rear lighting wiring harness	2
750 001 046	A	Faisceau arrière / Rear wiring harness	1
750 001 047		Faisceau phare de recul et gyrophare / Backup light and rotating light wiring harness	1
750 001 053		Faisceau éclairage de plaque / License plate lighting wiring harness	1
750 001 055		Feu de gabarit équipé / Equiped vehicle gauge light	2
750 004 021		Faisceau potentiomètre accélérateur/ Accelerator potentiometer wiring harness	1

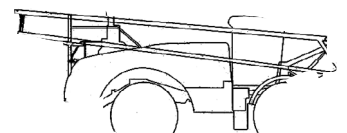

Référence Item number	Indice Index	Désignation Designation	Qté/machine Qty/sprayer
OPTIONS			
176 071 000		Pédale équipée (H-Tronic) / H-Tronic's equiped pedal	1
234 548 000		Faisceau rampe pneumatique 9 tronçons 36 m / 36 m 9 sections pneumatic boom wiring harness	1
234 843 000		Faisceau vanne supplémentaire / Add valve wiring harness	
234 847 000	A	Faisceau avec coupure sur poignée (5 tronçons) / Wiring harness with cut on joystick (5 sections)	1
234 848 000	A	Faisceau avec coupure sur poignée (6 tronçons) / Wiring harness with cut on joystick (6 sections)	1
234 849 000	A	Faisceau avec coupure sur poignée (7 tronçons) / Wiring harness with cut on joystick (7 sections)	1
234 850 000	A	Faisceau avec coupure sur poignée (8 tronçons) / Wiring harness with cut on joystick (8 sections)	1
234 851 000	A	Faisceau avec coupure sur poignée (9 tronçons) / Wiring harness with cut on joystick (9 sections)	1
234 874 000		Faisceau rampe pneumatique 8 tronçons 36 m / 36 m 8 sections pneumatic boom wiring harness	1
234 875 000		Faisceau rampe pneumatique 6 tronçons 36 m / 36 m 6 sections pneumatic boom wiring harness	1
234 878 000		Faisceau alimentation aux tronçons extérieur / Supply wiring harness to outer sections	1
750 001 015		Faisceau rampe pneumatique 24-28 m 7 tronçons / 24-28 m 7 sections pneumatic boom wiring harness	1
750 001 017		Faisceau relais crabotage pour option H-Tronic / jaw clutching relay wiring harness for H-Tronic option	1
750 001 019		Faisceau rampe pneumatique 40 m 8 tronçons / 40 m 8 sections pneumatic boom wiring harness	1
750 001 020		Faisceau pompe LINDE / LINDE pump wiring harness	1
750 001 021		Faisceau rampe pneumatique 45 m 9 tronçons / 45 m 9 sections pneumatic boom wiring harness	1
750 001 022		Faisceau rampe pneumatique 42 m 7 tronçons / 42 m 7 sections pneumatic boom wiring harness	1
750 001 024		Faisceau poignée Stabilis® / Stabilis® joystick wiring harness	1
750 001 025		Faisceau principal Stabilis® / Stabilis® main harness	1
750 001 026		Contre faisceau Stabilis® / Stabilis® counter wiring harness	1
750 001 027		Faisceau rampe pneumatique 32 m 8 tronçons (petit cadre) / 32 m 8 sections pneumatic boom wiring harness (small frame)	1
750 001 028		Faisceau option bras principaux indépendant / independant main boom option wiring harness	2
750 001 029		Faisceau rampe pneumatique 44-42 m 9 tronçons / 44-42 m 9 sections pneumatic boom wiring harness	1
750 001 032		Faisceau capteur de vitesse GPS / GPS Speed sensor wiring harness	1
750 001 034		Faisceau fin de course pour porte de cabine (option 40 km/h) / Limit switch wiring harness for cab's door (40 km/h option Fr)	1
750 001 035		Faisceau clapet dépli repli support de rampe (option 40 km/h) / Boom frame fold-unfold check valve wiring harness (40 km/h Fr)	1
750 001 036		Faisceau clapet bras principal (option 40 km/h) / Main boom check valve wiring harness (40 km/h Fr)	2
750 001 037	A	Faisceau bouton dépli repli support de rampe (option 40 km/h) / Boom frame fold-unfold knob wiring harness (40 km/h option Fr)	1
750 001 048		Faisceau avec coupure sur poignée 5 tronçons Stabilis® / Wiring harness with cut on joystick (Stabilis® 5 sections)	1
750 001 049		Faisceau avec coupure sur poignée 6 tronçons Stabilis® / Wiring harness with cut on joystick (Stabilis® 6 sections)	1
750 001 050		Faisceau avec coupure sur poignée 7 tronçons Stabilis® / Wiring harness with cut on joystick (Stabilis® 7 sections)	1
750 001 051		Faisceau avec coupure sur poignée 8 tronçons Stabilis® / Wiring harness with cut on joystick (Stabilis® 8 sections)	1
750 001 052		Faisceau avec coupure sur poignée 9 tronçons Stabilis® / Wiring harness with cut on joystick (Stabilis® 9 sections)	1
750 001 054		Faisceau gyrophare arrière / Rear rotating light wiring harness	1
750 001 059		Faisceau adaptation connecteur moteur hydraulique 40 km/h / Hydraulic engine connector adaptation wiring harness (40 km/h Fr)	1
750 001 061		Faisceau rampe pneumatique 50-48 m 8 tronçons / 50-48 m 8 sections pneumatic boom wiring harness	1
750 001 063		Faisceau avec coupure sur poignée 4 tronçons / Wiring harness with 4 sections cut on joystick	1
750 001 064		Faisceau avec coupure sur poignée 4 tronçons Stabilis® / Wiring harness with 4 sections cut on joystick Stabilis®	1
750 004 003		Faisceau sonde 1 ^{ère} et 2 ^e vitesse / 1 st & 2 nd speed sensor wiring harness	1
750 004 004	A	Faisceau électrovanne pneumatique 1 ^{ère} et 2 ^e vitesse / 1 st & 2 nd speed pneumatic electrovalve wiring harness	1

Lors d'une commande d'un faisceau avec coupure sur poignée annuler la commande du faisceau poignée 234 787 000 C

For the order of wiring harness with cut on joystick, cancel the order of joystick wiring harness number 234 787 000 C

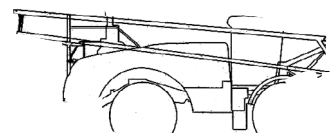

Km/h Modèles	25	40
17/39	X	X
21/39	X	X
23/45	X	

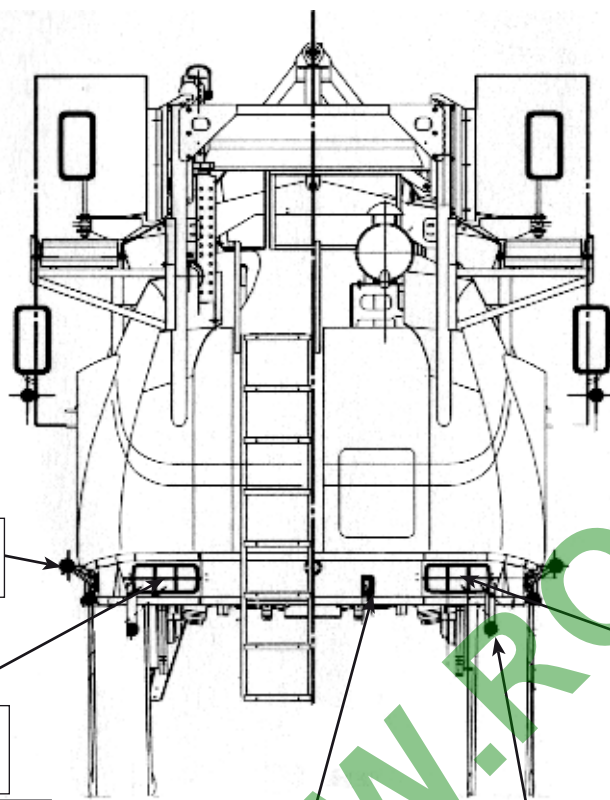

Feux de gabarit AR
Rear size light
Ref 234 794 000

Feux arrière gauche
Rear left light
Ref 047 029 000

Ampoule poirette/Pearshaped bulb
Ref 234 100 000/10 Watts
Ampoule/Bulb
Ref 234 410 000/5 Watts

Feux de plaque
Registration n° light
Ref 234 312 000

Ampoule/Bulb
Ref 234 580 000

Catadioptre
Retro-reflector
Ref 162 118 000

Ampoules/Bulb voir
Chapitre 1
planche D02

Feux avant droit
Front right light
Ref 234 519 000

Feux arrière droit
Rear right light
Ref 047 028 000

Ampoule poirette/Pearshaped bulb
Ref 234 100 000/10 Watts
Ampoule/Bulb
Ref 234 410 000/5 Watts

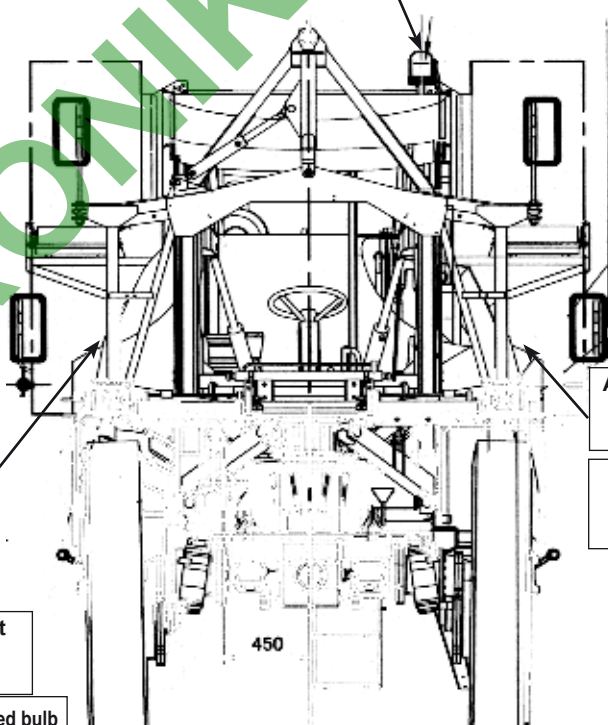

Lampe à iode
Iodine lamp
Ref 234 747 000

Gyrophare/Rotatory light
234 744 000

Ampoules/Bulb voir
Chapitre 1
planche D02

Feux avant gauche
Front left light
Ref 234 520 000

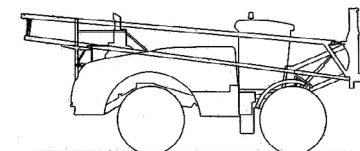

**CATALOGUE MAESTRIA
RAMPE AV 2004**

Correctif mars 2006/March '06 correction

SIGNALISATION		6 B01 04/07/05
---------------	---	----------------------

Km/h Modèles	25	40
17/39	X	X
21/39	X	X
23/45	X	

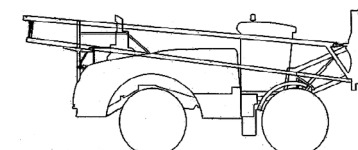
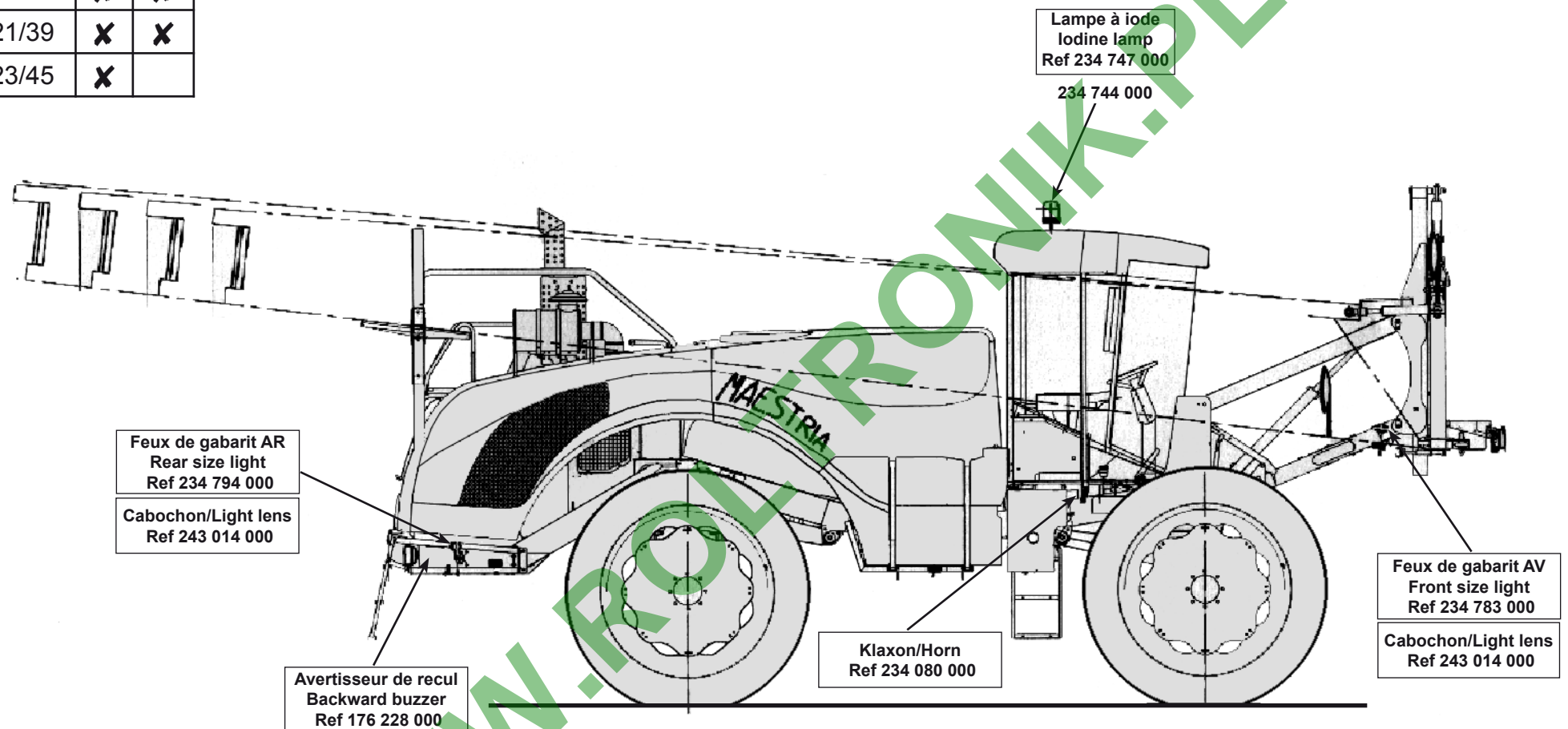

**CATALOGUE MAESTRIA
RAMPE AV 2004**

Correctif mars 2006/March '06 correction

SIGNALISATION



6
B02
04/07/05

AUTOCOLLANTS SECURITÉ / SECURITY STICKERS

						
148 236 000	148 237 000	148 238 000	148 242 000	148 243 000	148 244 000	148 245 000
						
148 249 000	148 253 000	148 254 000	231 277 000	231 279 000	231 280 000	231 283 000
						
231 284 000	231 286 000	231 287 000	235 220 000	235 221 000		

AUTOCOLLANTS CABINE / CAB STICKERS

ATTENTION
SUR ROUTE METTRE L'INTERPTEUR SUR OFF-ARRET QUAND LE VOYANT POSITION ROUTE EST ALLUME

ATTENTION
NE JAMAIS COUPER TOUTE LA PULVERISATION AVEC LES INTERPTEURS DE TRONCONS POUR FERMER LE OUISES DEVIERS TRONCONS EN SERVICE UTILISER L'INTERPTEUR DE VANNE PRINCIPALE SITUÉ SUR LA POIGNEE

RINÇAGE DES RAMPES
-VANNE ASPIRATION POSITION RINÇAGE
-VANNE CIRCULATION FERMÉE
-INTERPTEUR DE SECTIONS POSITION MARCHÉ
-INTERPTEUR GÉNÉRAL POSITION MARCHÉ
-MOTEUR AU RALENTI EMBRAYER LA POMPE

232 177 000

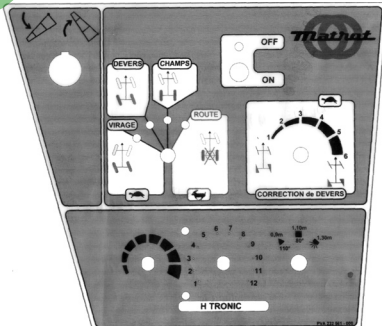

232 561 000

F P R

148 248 000

**frein a main
hand brake lever
handbremshebel**

148 103 000

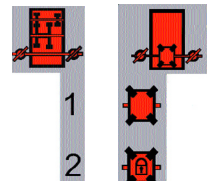

232 555 000 232 556 000

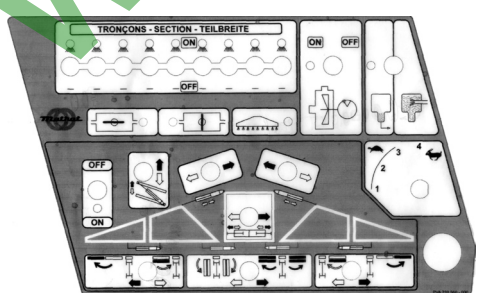

232 560 000

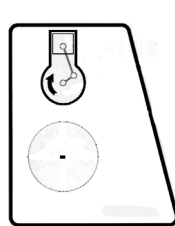

232 562 000

MAESTRIA

Open	Plati de serval	Control	Motors
Close	case R tonic	discharge	filter
R1	R2	R3	R4
R5	R6	R7	R8
R9	R10	R11	R12
R13	R14	R15	R16
R17	R18	R19	R20
R21	R22	R23	R24
R25	R26	R27	R28
R29	R30	R31	R32
R33	R34	R35	R36
R37	R38	R39	R40
R41	R42	R43	R44
R45	R46	R47	R48
R49	R50	R51	R52
R53	R54	R55	R56
R57	R58	R59	R60
R61	R62	R63	R64
R65	R66	R67	R68
R69	R70	R71	R72
R73	R74	R75	R76
R77	R78	R79	R80
R81	R82	R83	R84
R85	R86	R87	R88
R89	R90	R91	R92
R93	R94	R95	R96
R97	R98	R99	R100

750001023

AUTOCOLLANTS VANNES / VALVES STICKERS

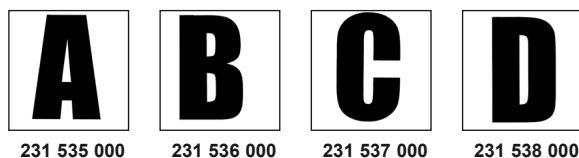

2B		
2A		
3B		
1A+RO		
1A		
1C+R10		
5C		
5A		
4A		
4D		

238 617 000

AUTOCOLLANTS / STICKERS

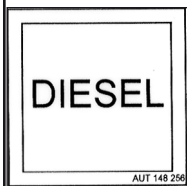

148 256 000



148 257 000



148 139 000

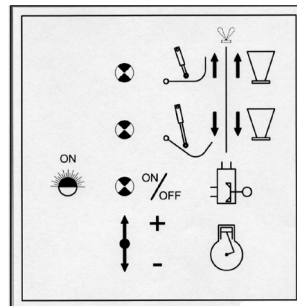
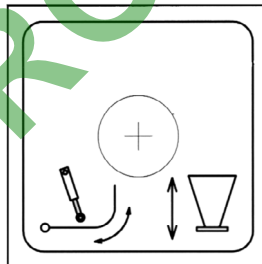

MAESTRIA

231 531 000

MAESTRIA

231 533 000



250 030 000



232 157 000

232 740 000

Modèles \ Km/h	25	40
17/39	X	X
21/39	X	X
23/45	X	

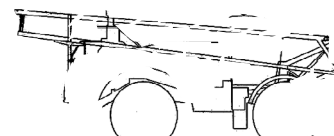
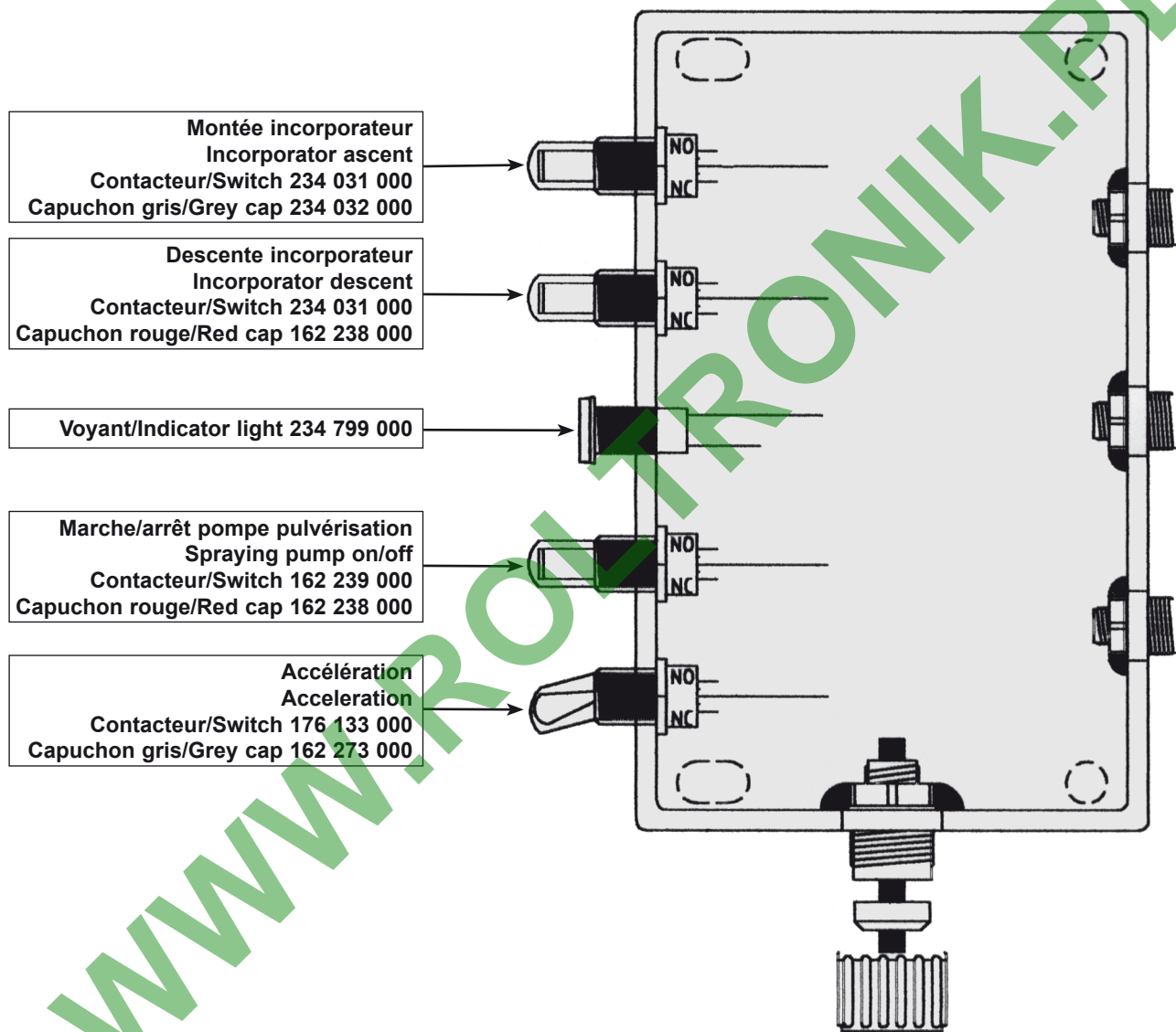

Km/h Modèles	25	40
17/39	X	X
21/39	X	X
23/45	X	

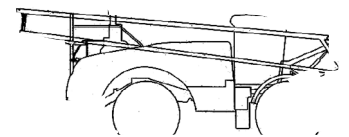
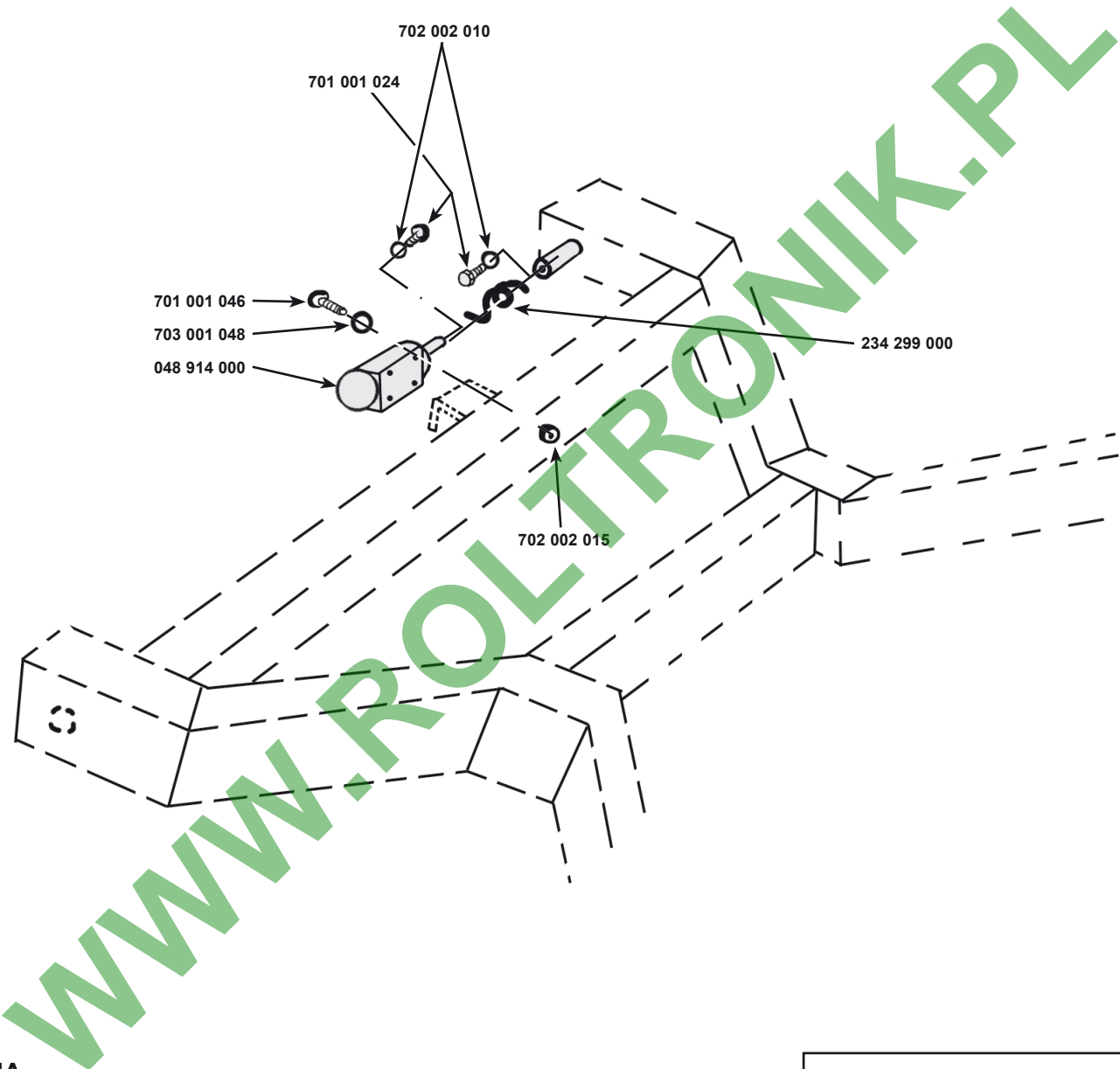

CATALOGUE MAESTRIA
RAMPE AV 2004
 Ajout mars 2006/March '06 Add-on

KIT «H-TRONIC» "H-TRONIC" KIT		6 E01 13/03/06
----------------------------------	---	----------------------

Boîtier complet
048 914 000

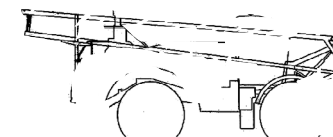
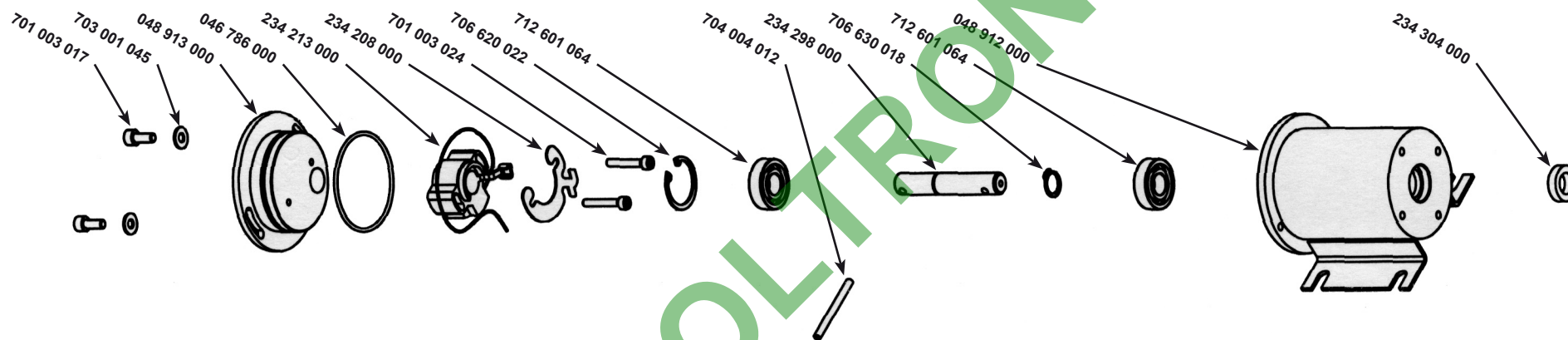

CATALOGUE MAESTRIA
RAMPE AV 2004

Ajout mars 2006/March '06 Add-on

BOITIER «H-TRONIC»
"H-TRONIC" BOX



6
E02
29/03/06