

UN002779-AV

KIT RICAMBI / PART KITS

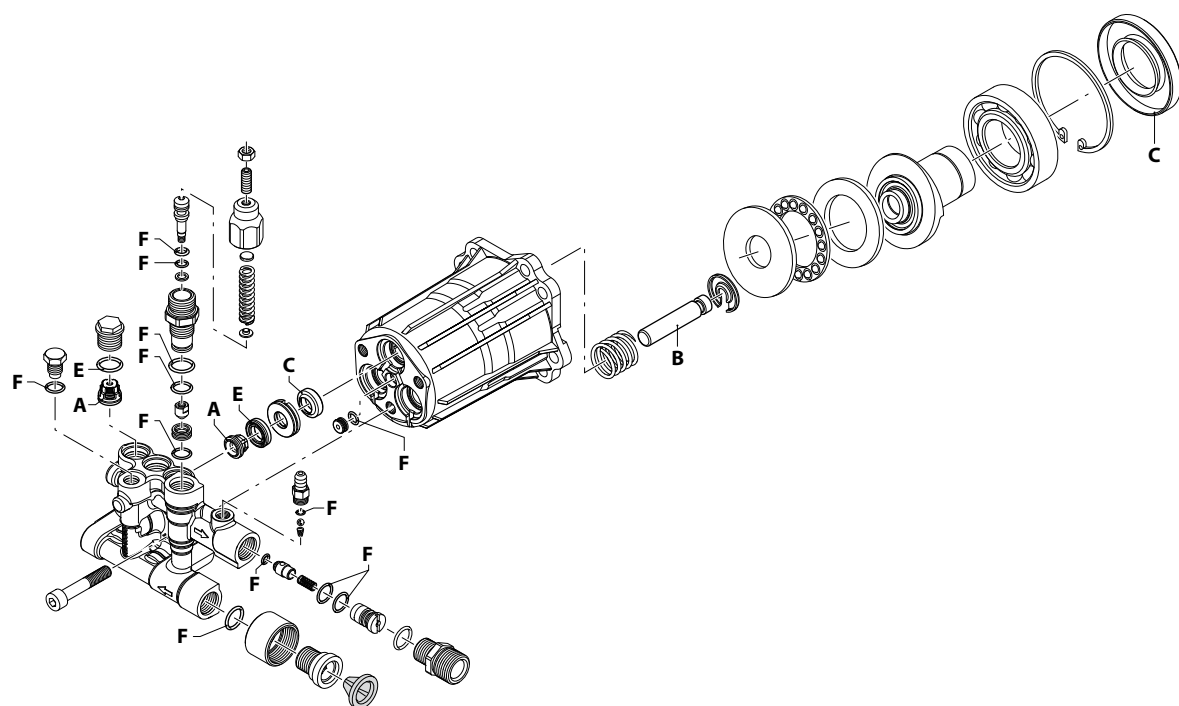

UN002780-AV



Pos.	Cod. Part n°	Denominazione	Description	Q.tà Q.ty	Note Vedi / See	Pos.	Cod. Part n°	Denominazione	Description	Q.tà Q.ty	Note Vedi / See
1	380410	Vite TCEI M 8x40	Screw	3	⊗ 25 Nm	50	2840050	Anello	Ring	3	
2	2840850	Testa pompa	Pump head	1		51	1980130	Ralla	Thrust bearing	1	
6	2840830	Tappo valvola	Plug	1		52	1980250	Gabbia completa	Complete cage	1	
7	600180	OR Ø 7,66x1,78	O-Ring	1		53	1980240	Ralla	Thrust bearing	1	
8	2840481	Tappo valvola	Plug	3	⊗ 25 Nm	54	2840900	Albero femmina	Hollow shaft	1	
9	740290	OR Ø 14x1,78	O-Ring	4		55	161060	Cuscinetto	Bearing	1	
10	2849051	Valvola completa	Complete valve	6		56	161050	Anello seeger Øi 72	Circlip	1	
11	1470210	OR Ø 9x1	O-Ring	1		57	2840310	Anello tenuta	Seal	1	
12	2840770	Sede	Seat	1		58	2840890	OR Ø 14x2	O-Ring	2	
13	2840760	Otturatore by pass	By-pass jet	1	⊗ 2 Nm						
14	820510	OR Ø 10,82x1,78	O-Ring	1							
15	2840750	Guida pistone	Piston guide	1	⊗ 25 Nm						
16	2760210	Anello antiestrusione	Ring	1							
17	660190	OR Ø 6,07x1,78	O-Ring	1							
18	2260100	OR Ø 6,02x2,62	O-Ring	1							
19	2760400	Pistone	Piston	1							
20	1980300	Dado M 6	Nut	1							
21	392840	Grano M 6X16	Grub screw	1							
22	2760480	Inserto manopola	Handle insert	1							
23	1980220	Piattello molla	Plate spring	2							
24	2760410	Molla	Spring	1							
25	2200141	Guarnizione	Gasket	3							
27	2840561	Boccola	Bushing	3							
29	1683500	Anello tenuta	Seal	3							
30	2840230	Corpo pompa	Housing	1							
31	480560	OR Ø 6,75x1,78	O-Ring	1							
32	2840710	Tappo olio	Oil plug	1							
33	480480	OR Ø 4,48x1,78	O-Ring	1							
34	1982520	Portagomma	Hose tail	1	⊗ 4 Nm						
35	1250280	Sfera	Ball	1							
36	1560520	Molla	Spring	1							
37	1460430	OR Ø 4x2,5	O-Ring	1							
38	2840350	Otturatore	Jet	1							
39	1343580	Molla	Spring	1							
40	800560	OR Ø 8,73x1,78	O-Ring	2							
41	2840340	Iniettore detergente	Detergent injector	1							
42	2840270	Raccordo aspirazione	Suction fitting	1	3/4" NH						
43	2840390	Raccordo aspirazione	Suction fitting	1	⊗ 25 Nm						
44	1266330	Filtro	Filter	1							
46	2840400	Raccordo mandata	Outlet fitting	1	⊗ 25 Nm						
48	2840060	Molla	Spring	3							
49	2840040	Pistone	Piston	3							

KIT RICAMBI - PART KITS

A=KIT 2233 valvole valves		B=KIT 2234 pistoni pistons		C=KIT 2236 tenute olio oil seals		E=KIT 42122 tenute acqua water seals	
Pos.	Q.ty	Pos.	Q.ty	Pos.	Q.ty	Pos.	Q.ty
10	6	49	3	29	3	25	3
				57	1		

SIMBOLOGIA - SYMBOLS

⊗ = Coppia serraggio (Tolleranza +0 / -10% Nm)
⊗ = Torque wrench (Allowance +0 / -10% Nm)

F=KIT 2237 OR O-Rings

Pos.	Q.ty	Pos.	Q.ty	Pos.	Q.ty	Pos.	Q.ty
7	1	26	3				
9	4	31	1				
11	1	33	2				
14	1	37	1				
17	1	40	2				
18	1	58	2				

