

Description

This pump has been developed with improvements that regard both drive and wet ends, which allow to increase the reliability and reduce the maintenance. The pump is of conventional design with crankshaft in high strength steel and supported by two Premium quality tapered rolling bearings produced by one of the world leader company of this sector. The connecting rods are in a special bronze alloy with excellent low-friction and mechanical performances, the pump head is nickel-plated for added protection against chemicals while the pump body is in anodized die-cast high-strength aluminium alloy and with a paint treatment that increase the corrosion resistance. The rear cover has been extended to contain a larger amount of oil and ensure a better lubrication, besides the discharge oil cap is magnetic so that attracts and collects all the metal particles coming from wear of the mechanical parts in motion. The pistons are in ceramic with a polishing treatment and with an expanded thickness that increase its strength and durability, while the pistons guide have a double scrolling diameter to extend the life of the oil seals. The water sealing system has been improved through a Long life double seal system in which the primary seal is able to withstand high pressures and the secondary prevents the leakage of water.

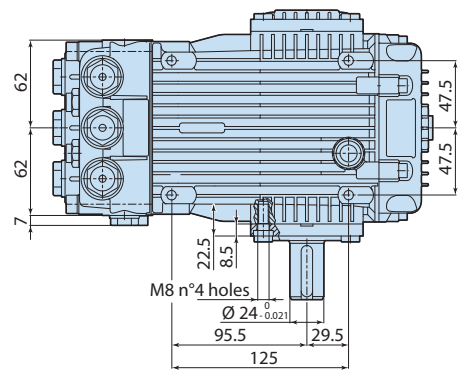

Details	Value
Category	Cleaning
Series	Premium
Pump type	JK 15.15 N
Versioning	N
ARCode	26169
Output (lt/min)	15
Output (gpm)	3,96
Pressure (bar)	150
Pressure (psi)	3,96
Power (hp)	5,5
Power (kw)	4
RPM	1450
Weight (kg)	9,5

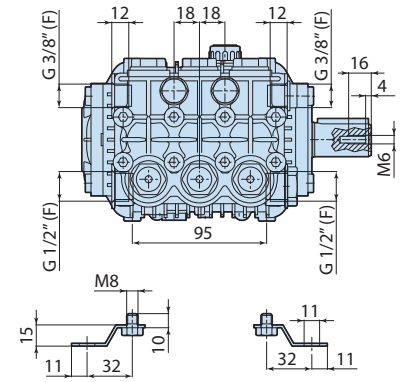
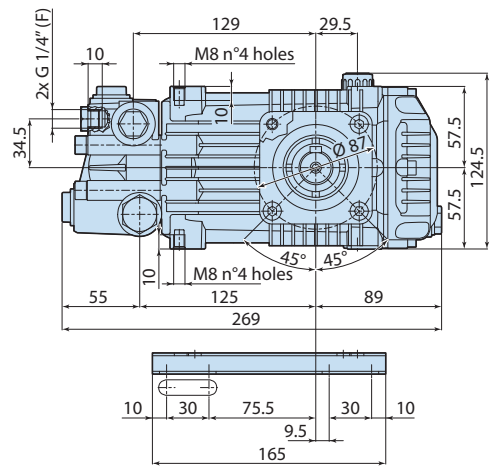
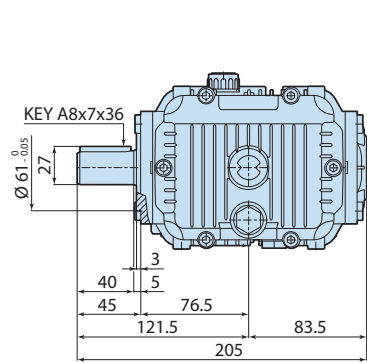

2288547