

Description

3-piston alternating volumetric pumps for use on cleaning units and industrial systems. Directly coupled to Honda GX 270 motor (code 4925). Pump body and cover in die-cast aluminium alloy. Rear cover with oil drain outlet, or incorporate oil sight glass. Pistons driven by crank-connecting rod mechanism. Pump shaft in pressed high-strength steel. Oversized friction bearings. Connecting rods in die-cast special low-friction zinc-aluminium alloy. Bronze connecting rods available. One-piece ceramic pistons. Pump head in pressed brass. Double gasket sealing system. Pump head internal components may be in different materials depending on application. Intake and delivery valves have plugs for easier maintenance. Various regulator valves and accessories can be connected to the pump head.

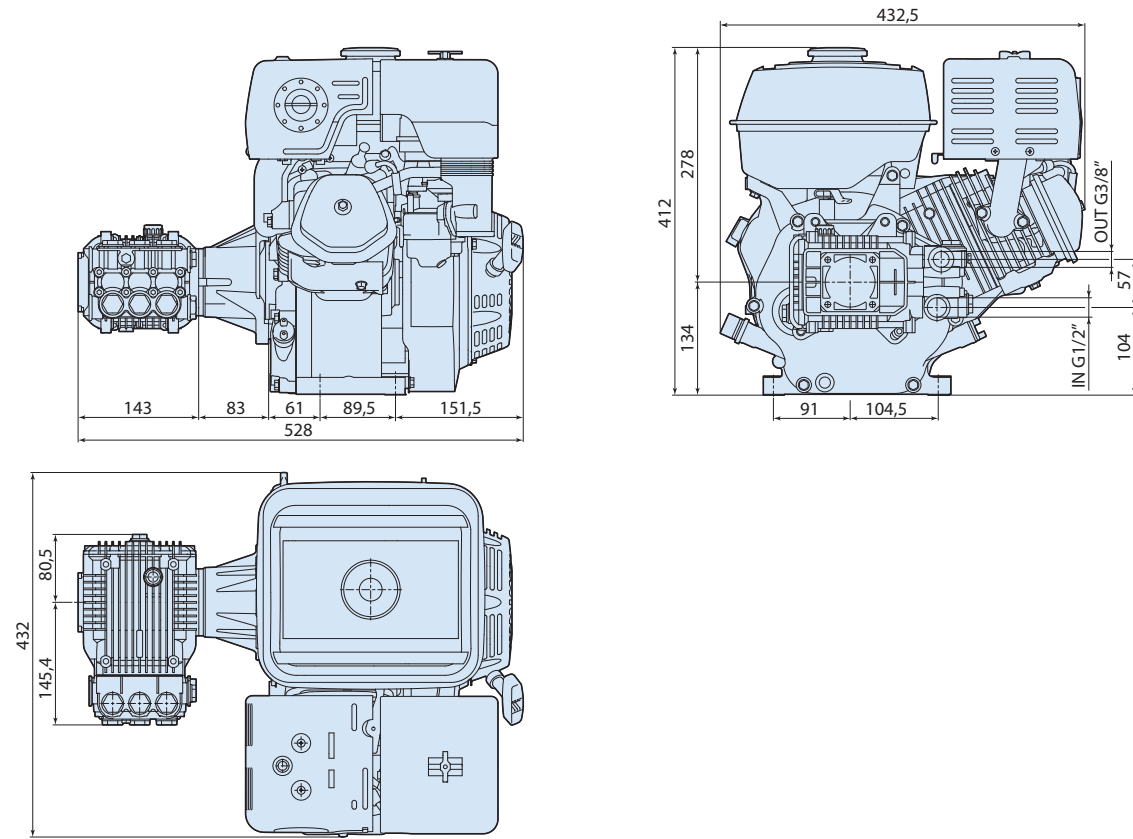

Details	Value
Category	Gasoline motor-pump units
Series	178 - XMV
Pump type	XMV 4 G20 HONDA GX 270-QX-Q4
Versioning	S
ARCode	20237
Output (lt/min)	15.1
Output (gpm)	4
Pressure (bar)	140
Pressure (psi)	2000
Power (hp)	9
RPM	3400
Weight (kg)	32



1788538