

UN00_2229-MR

KIT RICAMBI / PART KITS

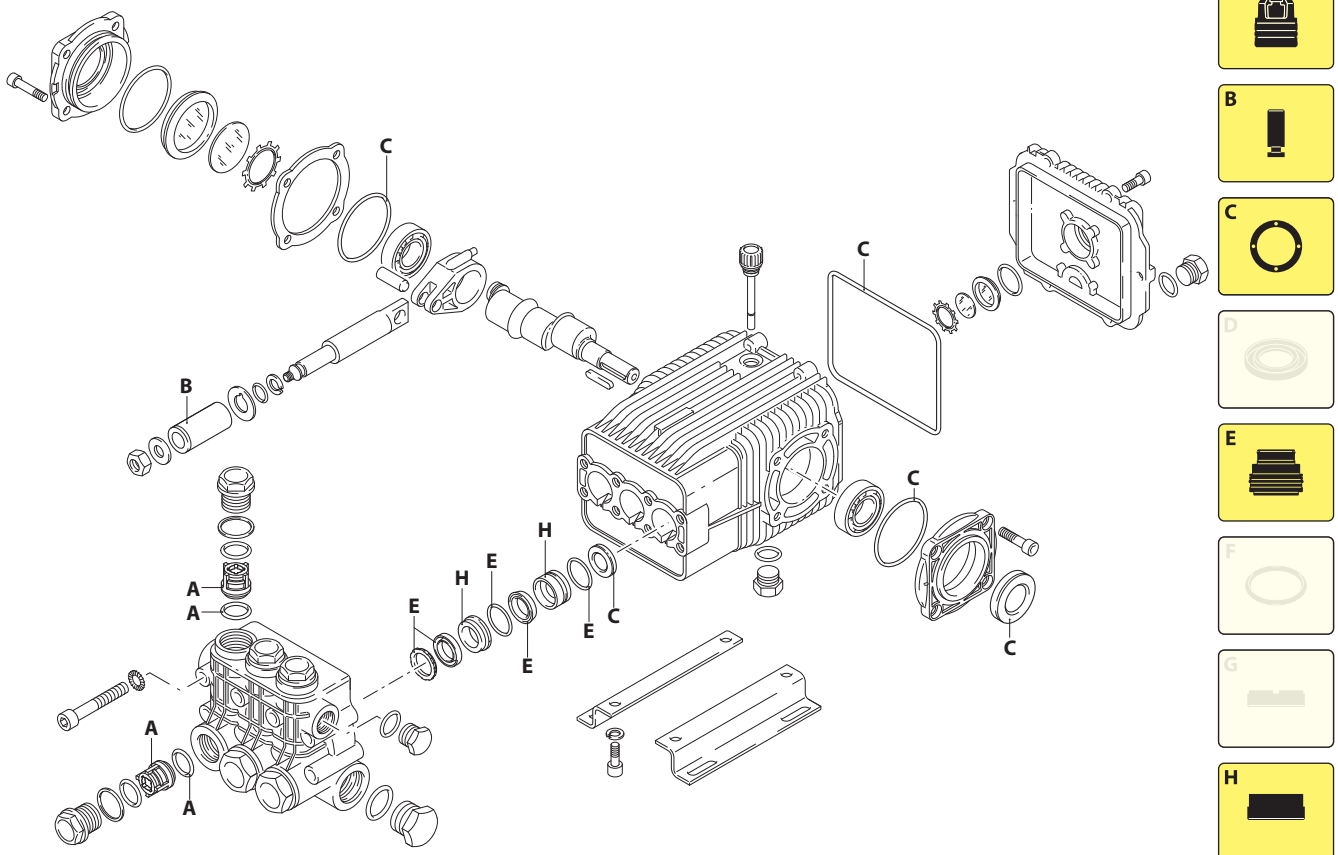

UN00_2230-DR

194 Series

CWX 950-1200-1750 rpm N version ø 24 mm



15.17 (20472)
18.10 (20473)
15.17 (20474)

Pos.	Cod.	Denominazione	Description	Qt	Note	Pos.	Cod.	Denominazione	Description	Qt	Note
1	1941360	Vite TCEI M10x80	Screw	8	C=42Nm	39	1940580	Rondella	Washer	3	
2	650530	Rondella	Washer	8		40	1940570	Dado	Nut	3	C=12Nm
3	1941790	Tappo nickelato	Plug	6	C=68Nm	41	1940410	Guarnizione OR Ø 132x3	O-ring	1	
4	1940150	Anello antiestrusione	Ring	6		42	1260430	Anello	Ring	1	
5	1140450	Guarnizione OR Ø 20,24x2,62	O-ring	12		43	1780690	Disco	Plate	1	
6	1949050	Valvola completa	Complete valve	6		44	1260250	Indicatore livello	Level gauge	1	
7	1941770	Testa	Head	1		45	1140450	Guarnizione OR Ø 20,24x2,62	O-ring	1	
8	550350	Guarnizione OR Ø 23,81x2,62	O-ring	1		46	1949010	Coperchio completo	Cover	1	
9	1140480	Tappo 3/4" G nickel	Plug	1	C=35Nm	47	1200430	Vite TCEI M6x16	Screw	6	C=10,4Nm
10	1981180	Tappo 3/8" G nickel	Plug	3	C=25Nm	48	1940370	Piede	Foot	2	Optional
11	740290	Guarnizione OR Ø 14x1,78	O-ring	3		49	200231	Rondella	Washer	4	Optional
12	1940440	Guarnizione Ø 20	Gasket	3		50	1940380	Vite TCEI 10x18	Screw	4	Optional C=50Nm
13	1940430	Guida pistone anteriore Ø 20	Piston guide	3		51	1941240	Supporto	Support	1	
14	1941220	Guarnizione tagliato Ø 22	Gasket	3		52	820680	Anello tenuta	Ring	1	(a)
15	1940470	Guarnizione Ø 20	Gasket	3		53	1949206	Premontaggio testa	Head assembly	1	
16	1940450	Guida pistone posteriore Ø 20	Piston guide	3							
17	820490	Guarnizione OR Ø 34,65x1,78	O-ring	3							
18	1940560	Anello tenuta	Ring	3							
19	1941330	Corpo pompa	Pump body	1							
20	1140370	Tappo	Plug	1							
21	650250	Linguetta	Key	1							
22	1940180	Albero marcato 3	Shaft	1	● ○						
	1940530	Albero marcato 6	Shaft	1	⊕						
23	1940051	Biella alluminio	Connecting-rod	3	● C=24,5Nm						
24	1940060	Spina	Pin	3							
25	1140410	Cuscinetto	Bearing	2							
26	1941380	Guarnizione OR Ø 66,34x2,62	O-ring	2							
27	1941390	Spessore 0,05 mm	Shim 0.05 mm	1÷3							
	1941400	Spessore 0,10 mm	Shim 0.10 mm	1÷3							
	1941410	Spessore 0,19 mm	Shim 0.19 mm	1÷3							
	1941420	Spessore 0,25 mm	Shim 0.25 mm	1÷3							
28	1941290	Anello	Ring	1							
29	1941260	Disco	Plate	1							
30	1941270	Indicatore livello	Level gauge	1							
31	100410	Guarnizione OR Ø 34,6x2,62	O-ring	1							
32	1949011	Coperchio	Cover	1							
33	850370	Vite TCEI M8x16	Screw	8	C=24,5Nm						
34	1940070	Pistone di guida	Piston	3							
35	1940120	Anello antiestrusione	Ring	3							
36	880840	Guarnizione OR Ø 9,25x1,78	O-ring	3							
37	960460	Disco	Plate	3							
38	1420430	Pistone Ø 20	Piston	3							

KIT RICAMBI - PART KITS

A=KIT 2780 valvole valves		B=KIT 2650 ø 20 pistoni pistons		C=KIT 2873 tenute olio oil seals		E=KIT 2782 ø 20 tenute acqua water seals	
Pos.	Q.ty	Pos.	Q.ty	Pos.	Q.ty	Pos.	Q.ty
5	6	38	3	18	3	12	3
6	6			26	2	14	3
				41	1	15	3
				52	1	17	3

H=KIT 2784 guida pistoni pistons guide							
Pos.	Q.ty	Pos.	Q.ty	Pos.	Q.ty	Pos.	Q.ty
13	3						
16	3						

SIMBOLOGIA - SYMBOLS

● Per / For CWX 15.17 cod. 20472	○ Per / For CWX 18.10 cod. 20473	⊕ Per / For CWX 15.17 cod. 20474
--	--	--

C Tolleranza coppia di serraggio +0÷-10% / Tightening torque tolerance +0÷-10%
 ● Avvitare con Loxeal 55-14 / Screw with Loxeal 55-14
 (a) Montare anello tenuta con attrezzo cod. 1941990 / Fit the seal with tool code nr. 1941990
 @ Posizionamento targa di identificazione / Identification plate positioning

Olio - Oil	
Tipo / Type	Quantità / Quantity
SAE 15W40	0,9 Kg